

[54] AUXILIARY AUTOMOTIVE VEHICLE BRAKE LIGHT

D. 289,205 4/1987 Biggs D26/28
1,857,210 5/1932 Nelson et al. D26/33 X
4,654,757 3/1987 Birkhauser 362/61

[75] Inventor: John S. Yuen, Kowloon, Hong Kong

Primary Examiner—Susan J. Lucas
Attorney, Agent, or Firm—Fay, Sharpe, Beall, Fagan,
Minnich & McKee

[73] Assignee: John Manufacturing Limited,
Kowloon, Hong Kong

[**] Term: 14 Years

[57] CLAIM

[21] Appl. No.: 875,745

The ornamental design for a auxiliary automotive vehicle brake light, as shown and described.

[22] Filed: Jun. 13, 1986

DESCRIPTION

[30] Foreign Application Priority Data

Dec. 16, 1985 [GB] United Kingdom 1031135

[52] U.S. Cl. D26/29

[58] Field of Search D26/28-36;
362/61, 66, 80-83, 267, 269, 275, 285, 362, 427;
340/70, 72, 81 R, 82, 84, 87, 90-94, 107, 105,
108

FIG. 1 is a front elevational view of an auxiliary automotive vehicle brake light showing my new design;
FIG. 2 is a bottom plan view thereof;
FIG. 3 is a top plan view thereof;
FIG. 4 is a left side elevational view thereof;
FIG. 5 is a right side elevational view thereof;
FIG. 6 is a right side elevational view thereof, with the light in an alternative position;
FIG. 7 is a cross-sectional view thereof taken along line 7-7 of FIG. 3;
FIG. 8 is a rear perspective view thereof.

[56] References Cited

U.S. PATENT DOCUMENTS

D. 283,843 5/1986 Payne et al. D26/28

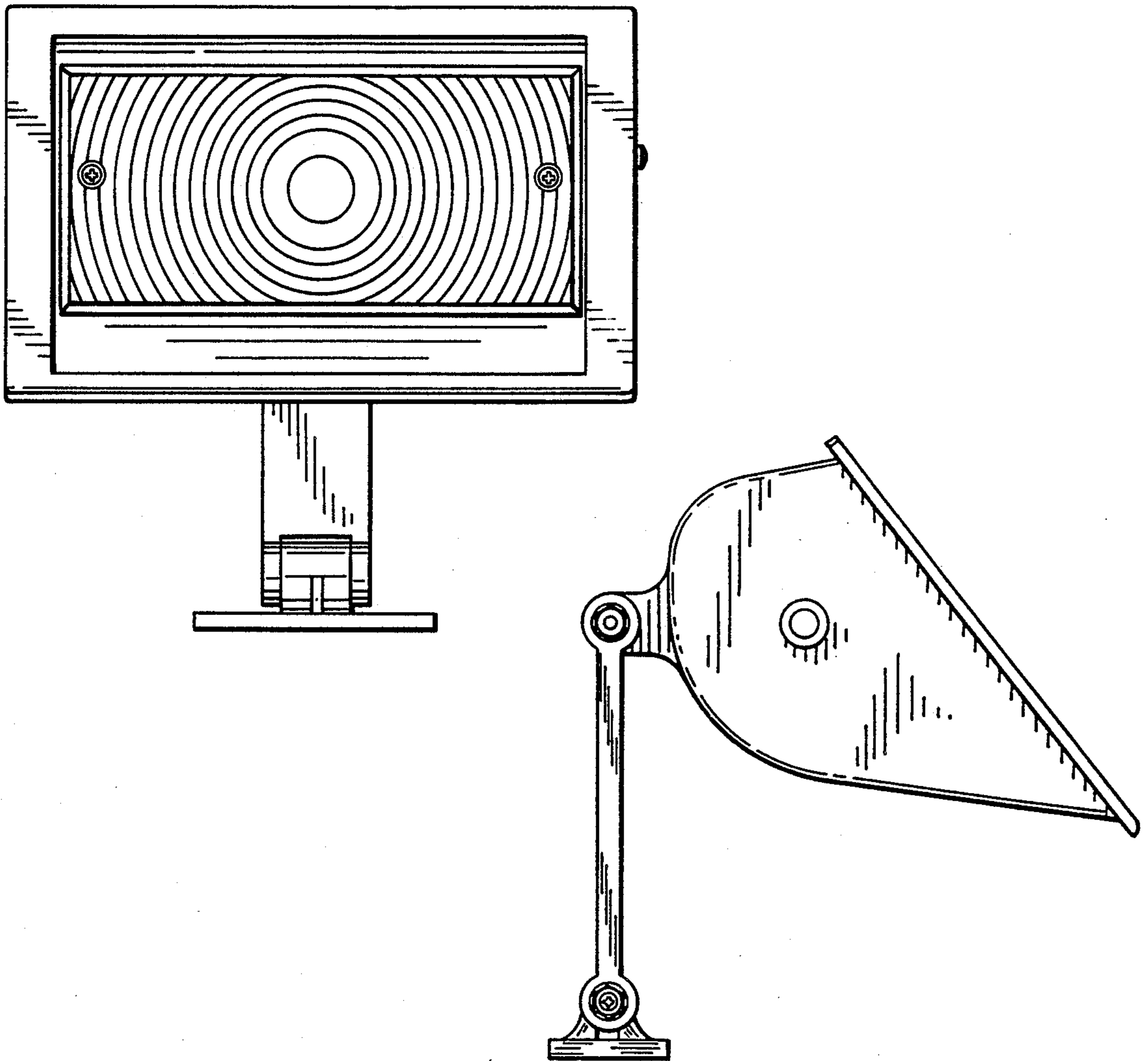

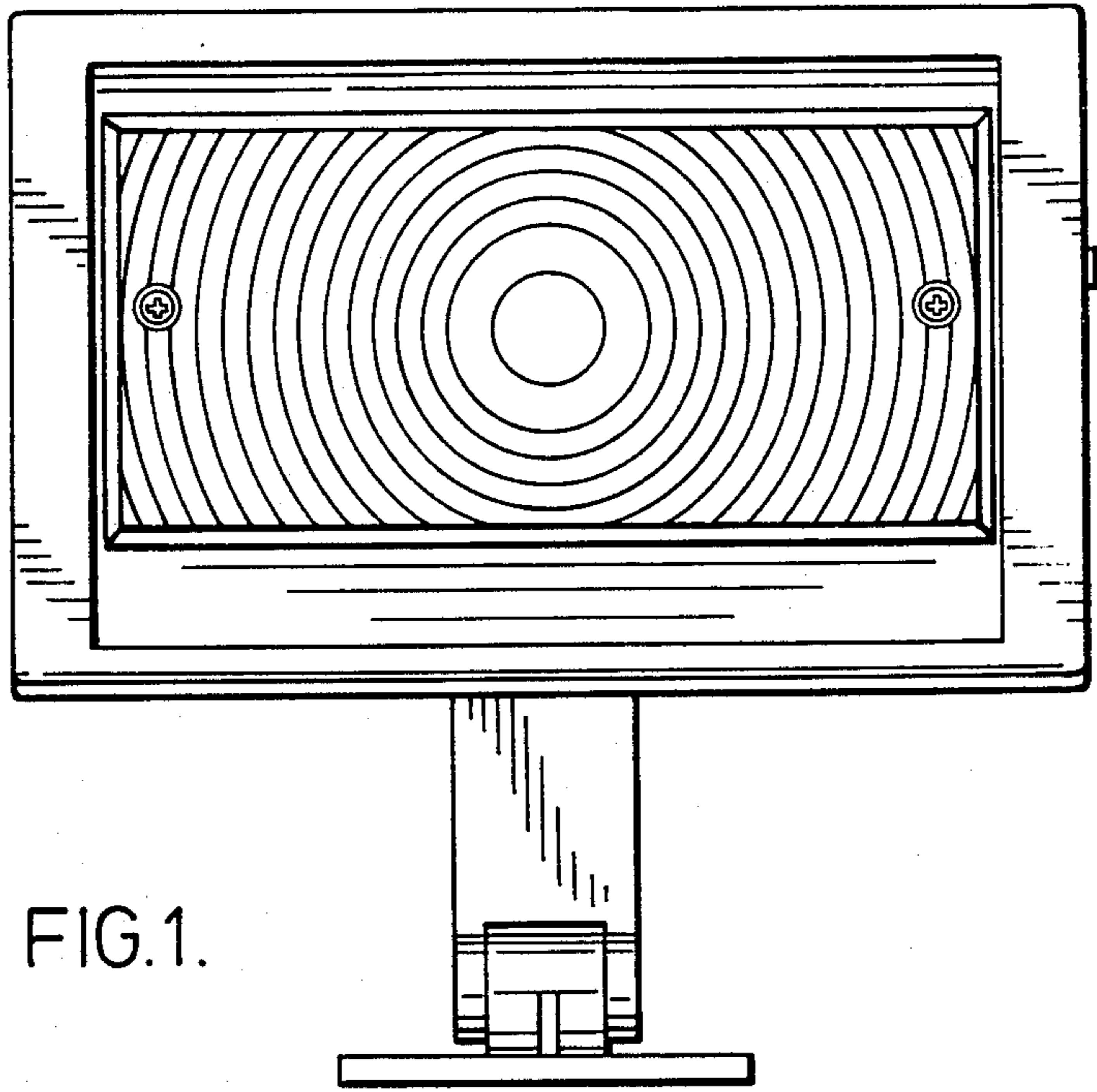

FIG. 1.

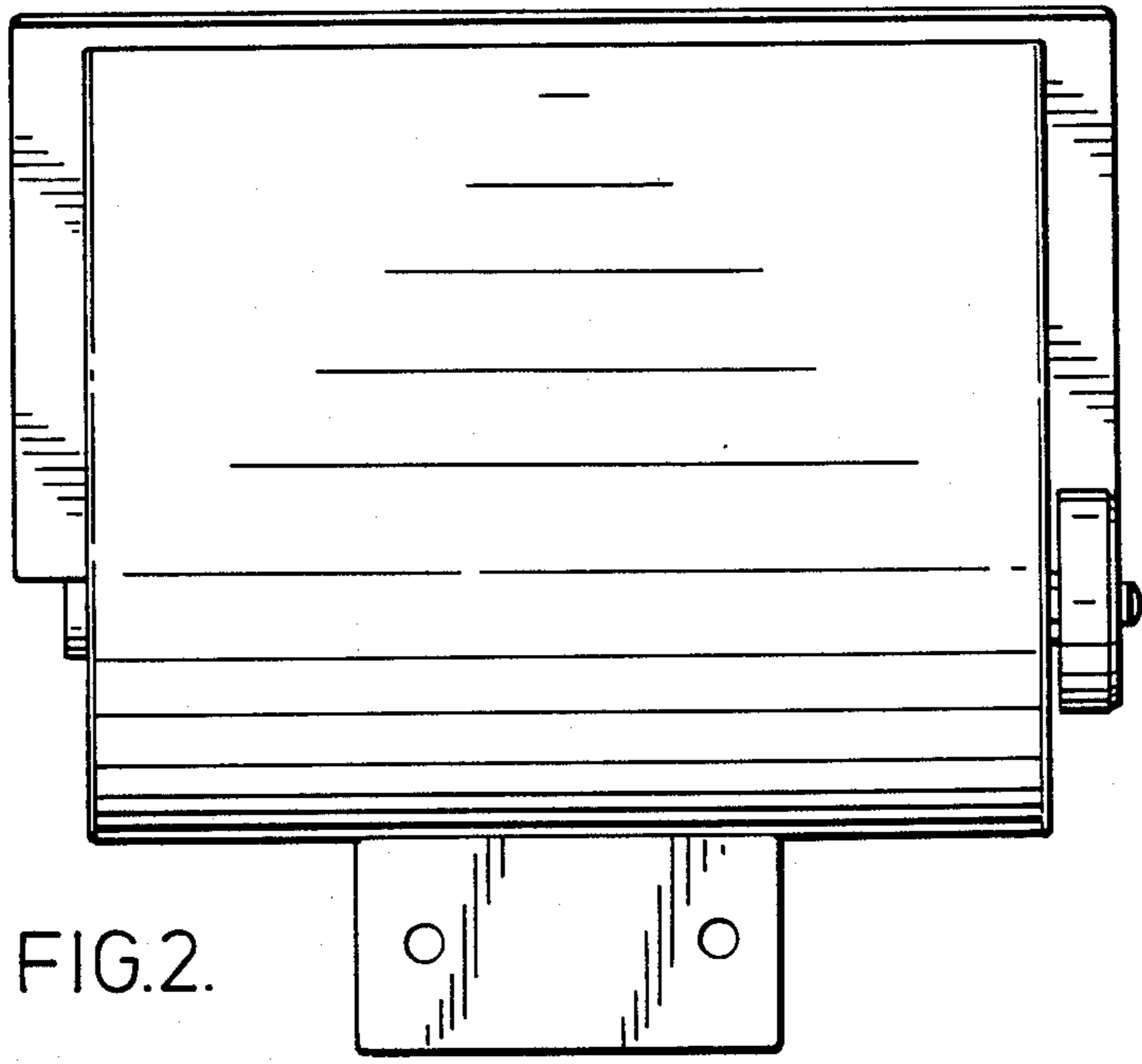

FIG. 2.

FIG. 3.

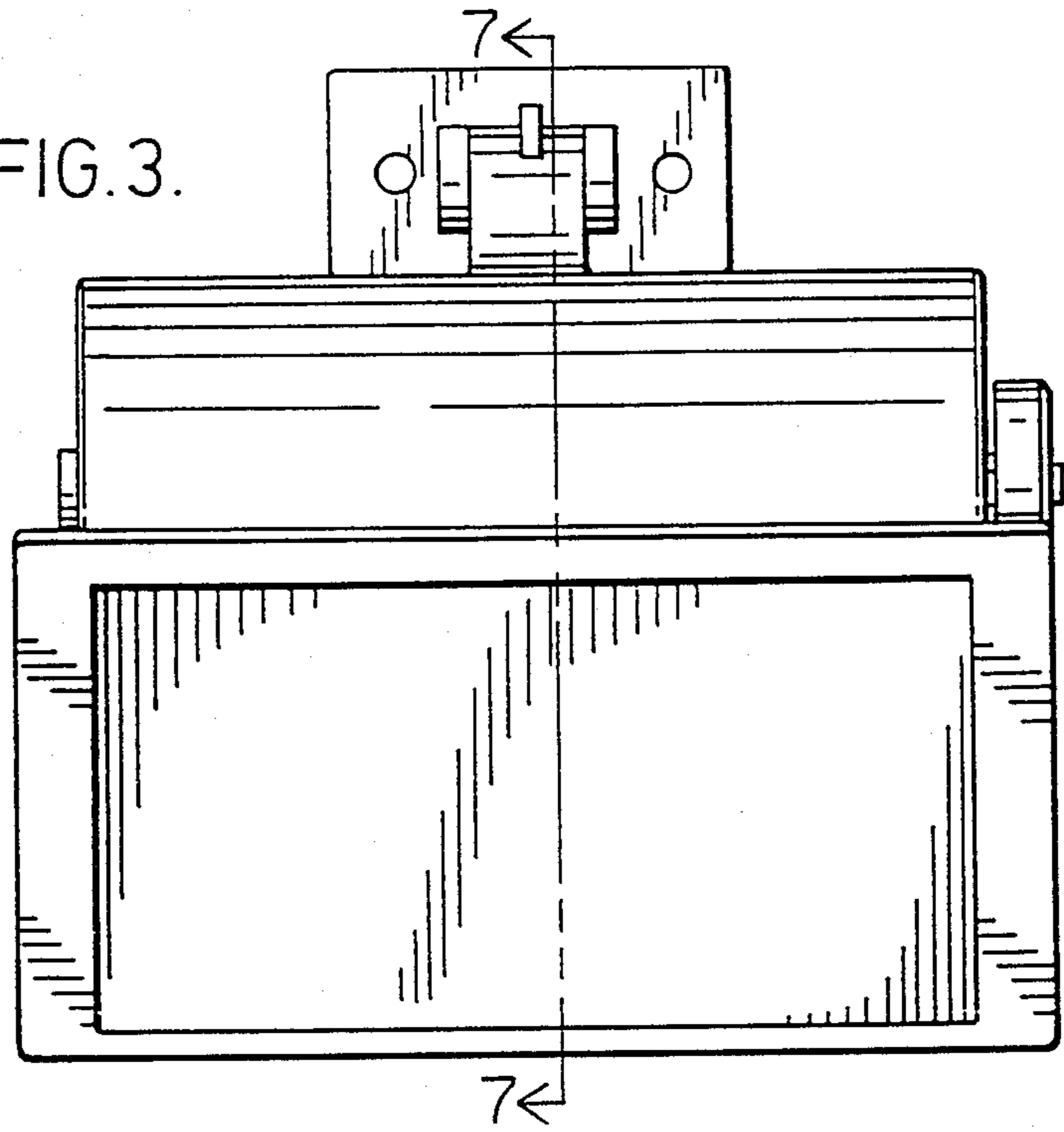
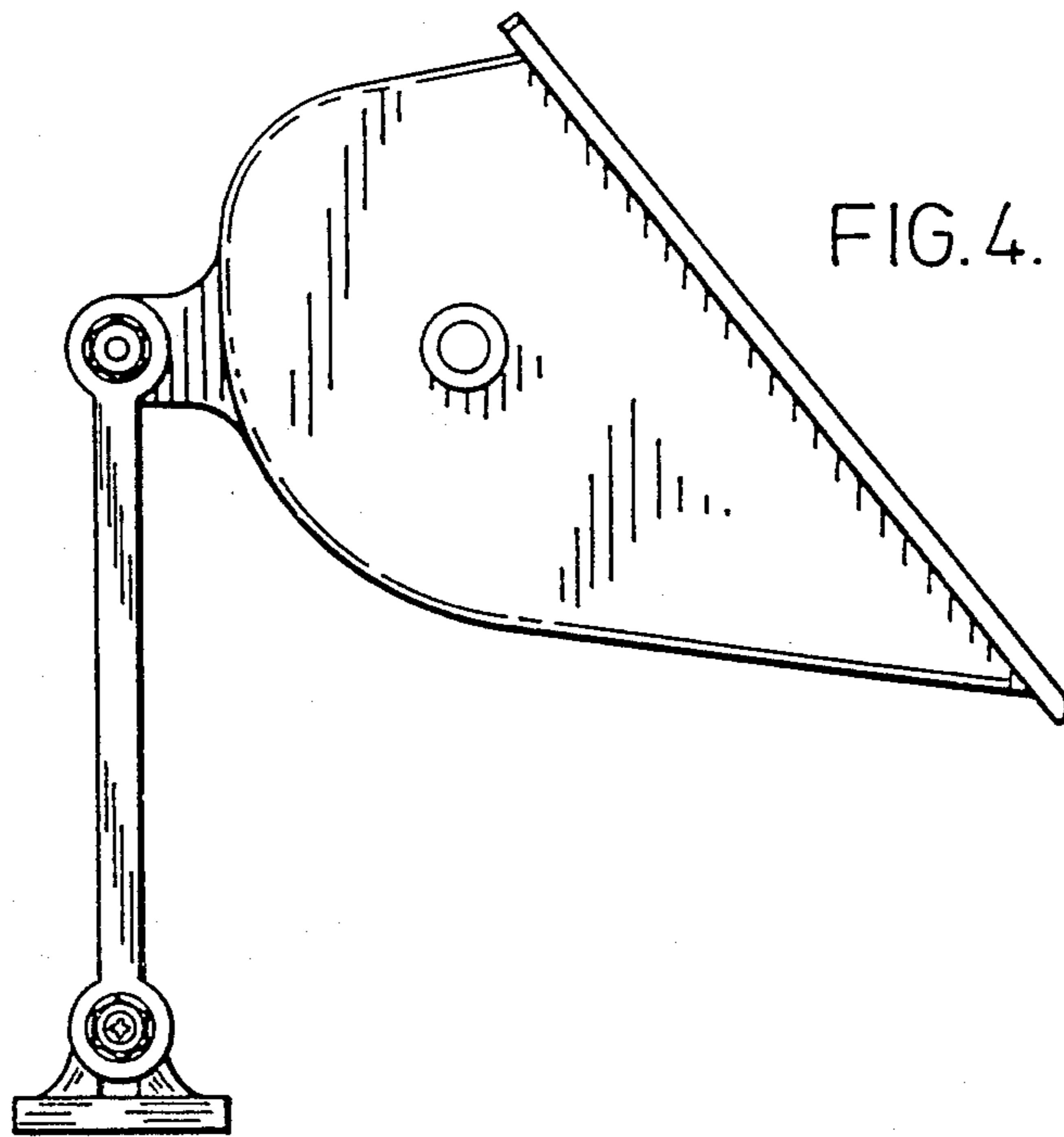

FIG. 4.



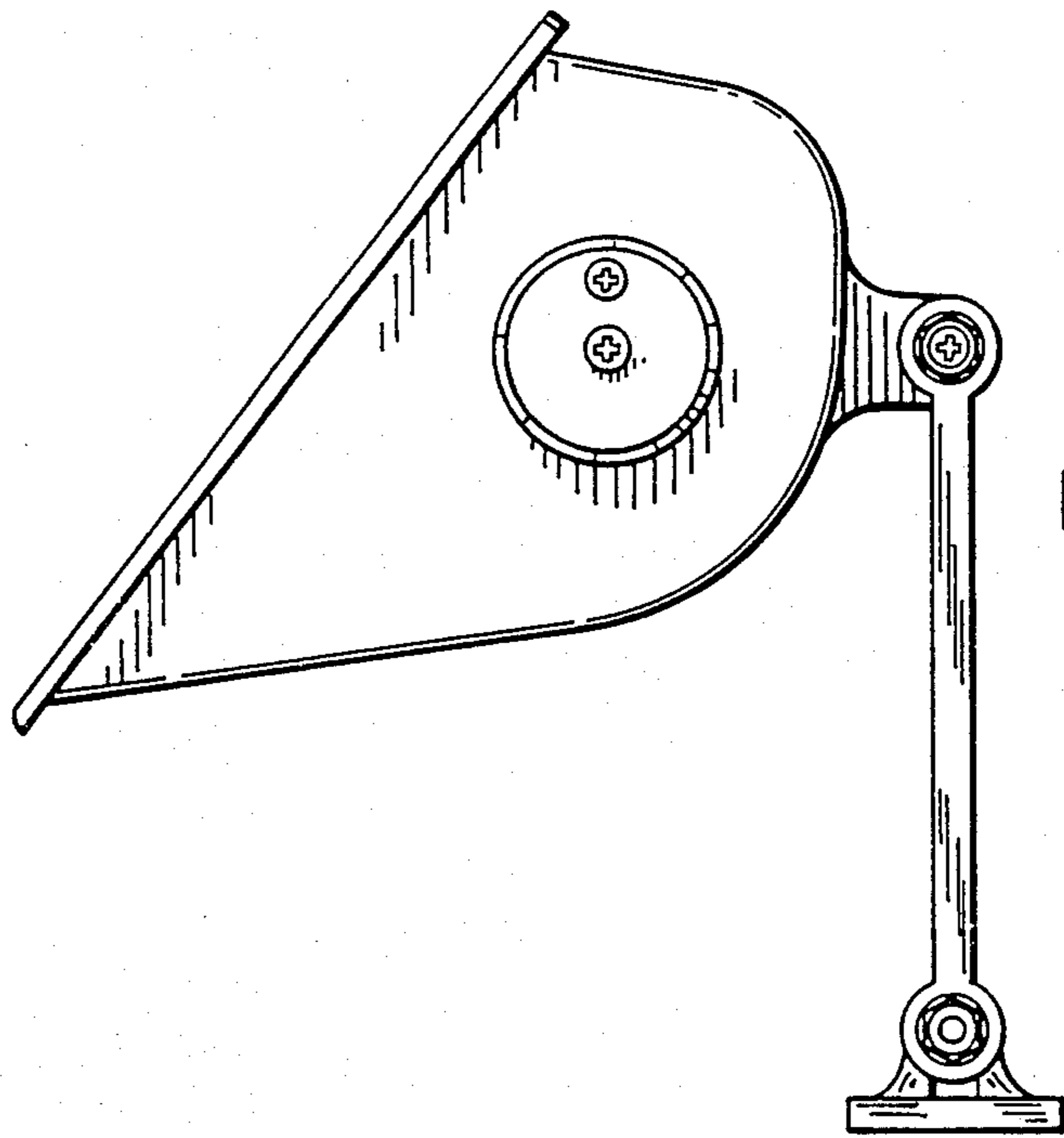

FIG. 6.

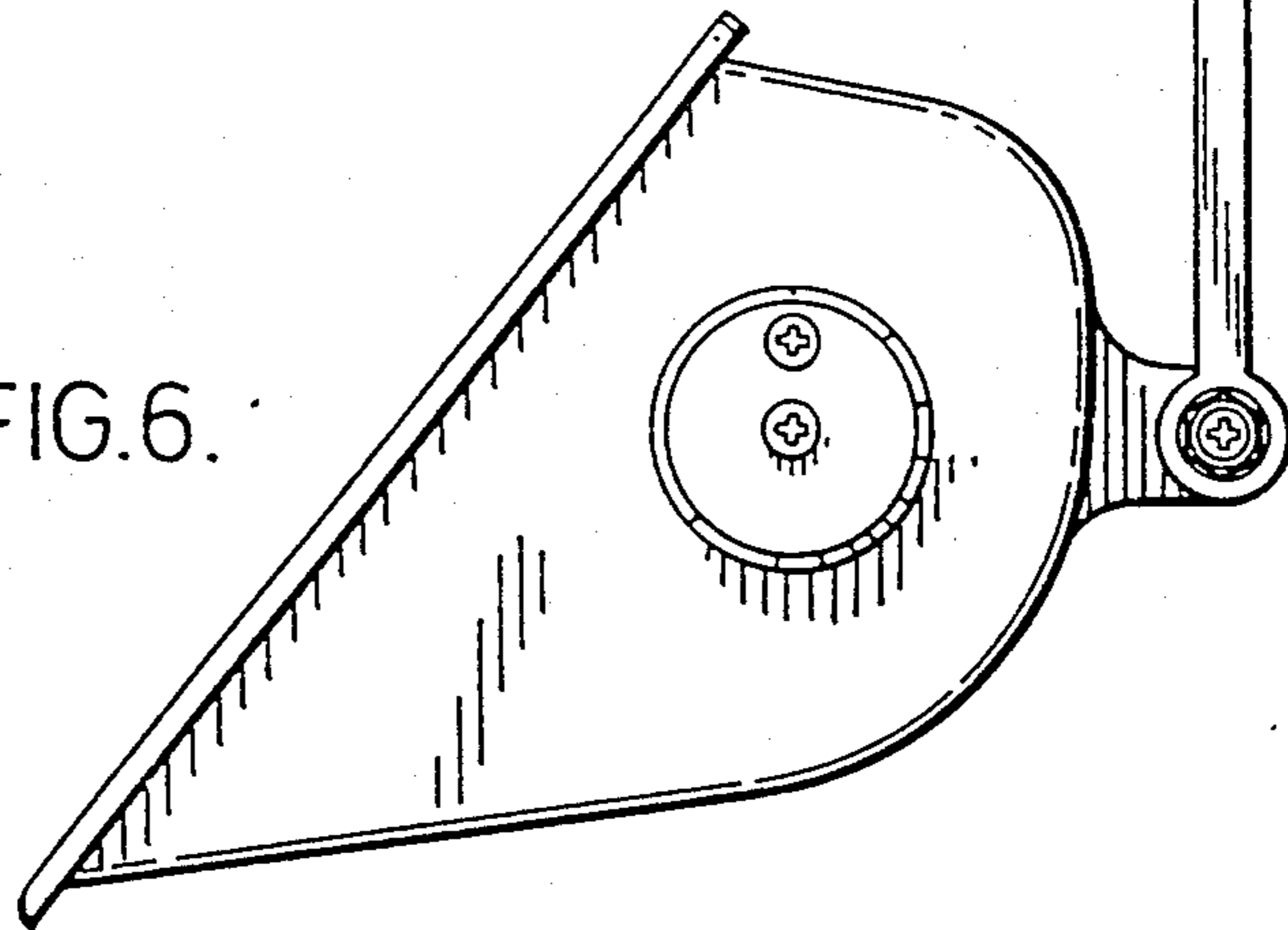
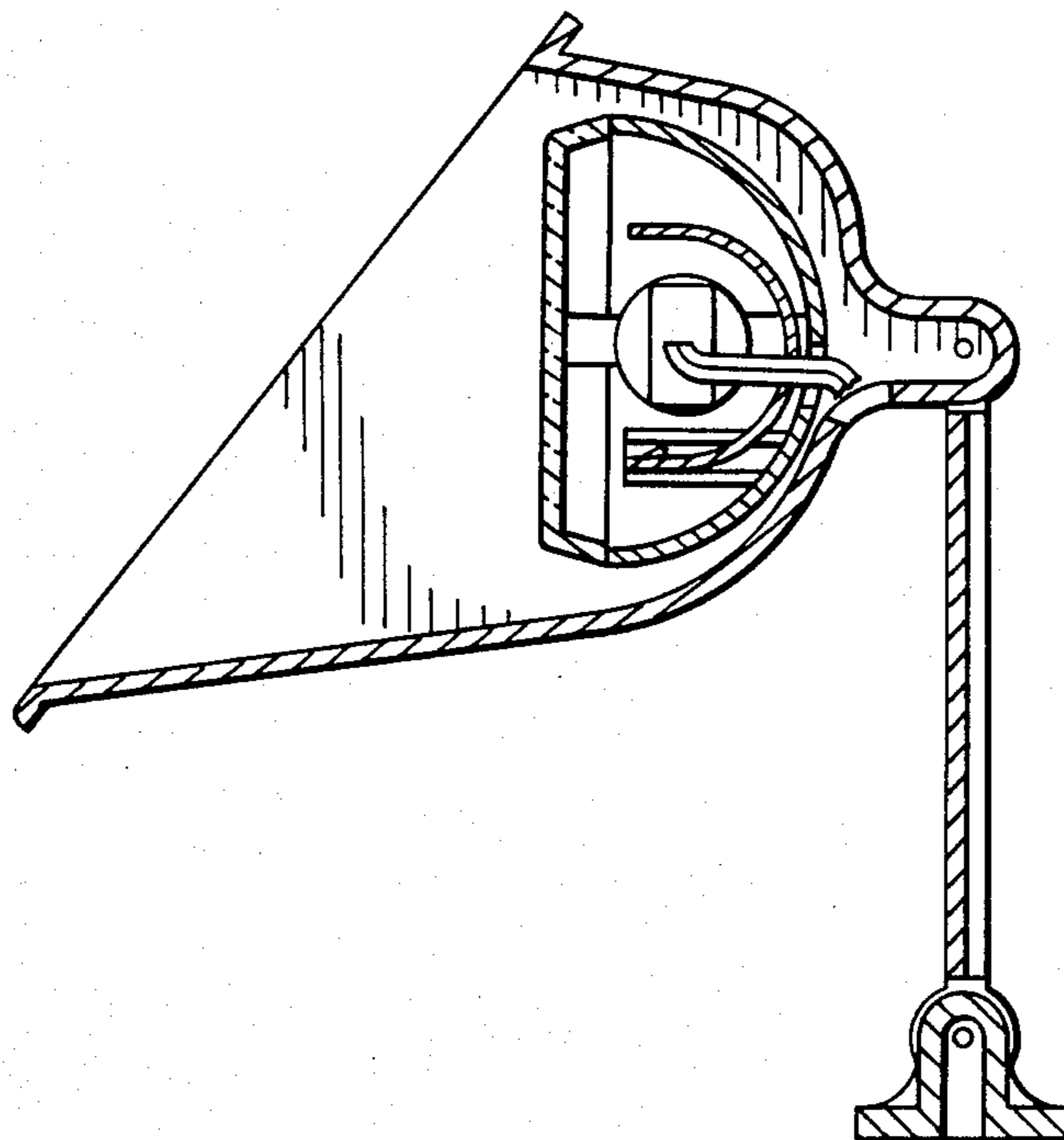

FIG. 7.



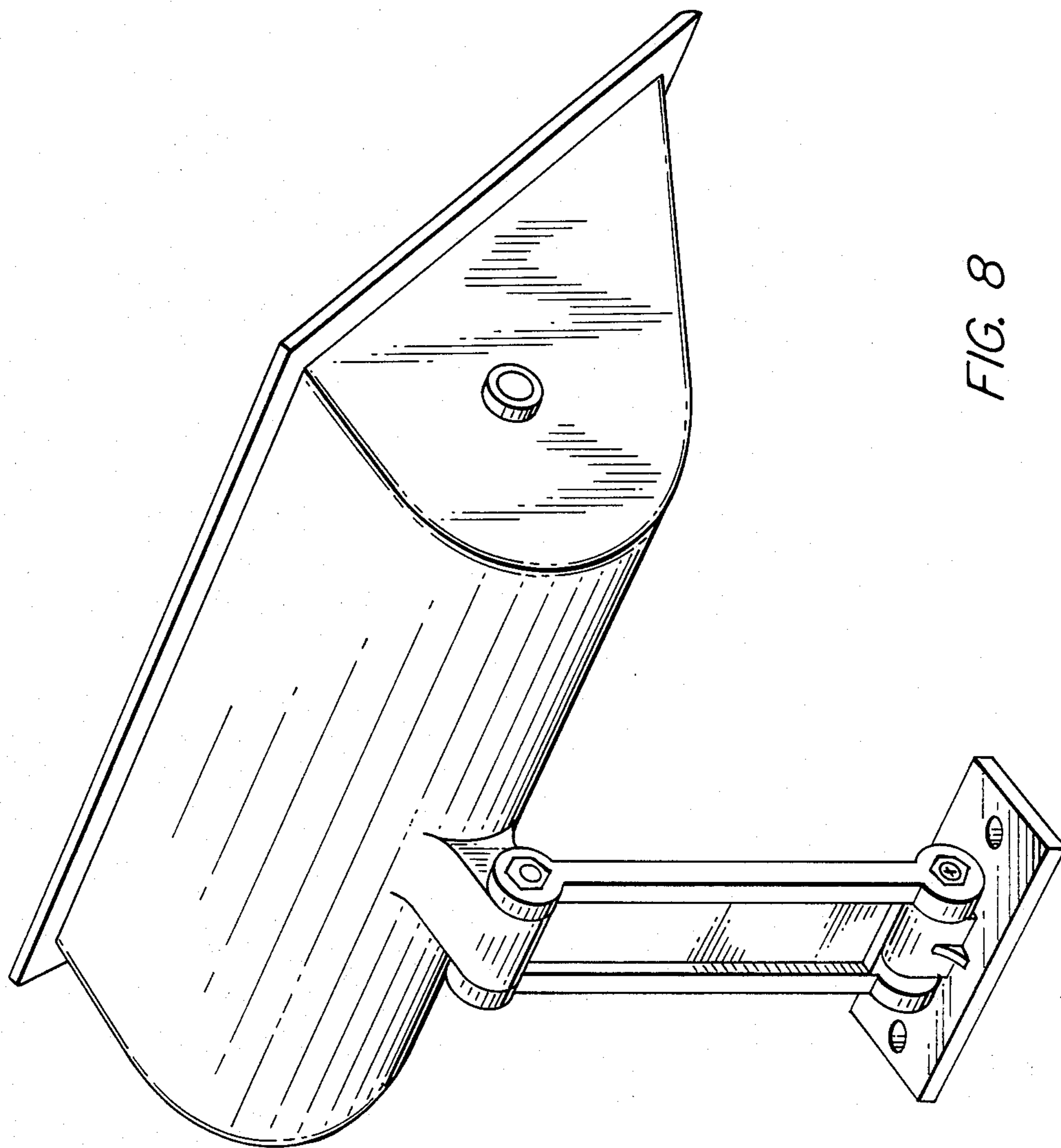

FIG. 8