

[54] WIND DEFLECTOR FOR MOTOR VEHICLES

3,785,699 1/1974 Molaskey et al. .... D12/181  
4,347,781 9/1982 Hassell ..... 98/2.12

[76] Inventor: Bruno R. Giovannoni, P.O. Box 638, Isleton, Calif. 95641

Primary Examiner—James M. Gandy  
Attorney, Agent, or Firm—Lothrop & West

[\*\*] Term: 14 Years

[57] CLAIM

The ornamental design for a wind deflector for motor vehicles, as shown and described.

[21] Appl. No.: 140,838

[22] Filed: Jan. 4, 1988

[52] U.S. Cl. .... D12/181

[58] Field of Search ..... D12/181; 98/2.12; 296/180.1, 91

DESCRIPTION

FIG. 1 is a perspective view of a wind deflector for motor vehicles, showing my new design;  
FIG. 2 is a top plan view thereof, the bottom being a mirror image of that shown;  
FIG. 3 is a front elevation view thereof;  
FIG. 4 is a right end elevation view thereof;  
FIG. 5 is a rear elevation view thereof; and  
FIG. 6 is a left end elevation view thereof.  
The outline representation of a car window and a car door frame, shown in broken lines in FIG. 1, is included solely for illustrative purposes, and forms no part of the claimed design.

[56] References Cited

U.S. PATENT DOCUMENTS

2,079,203	5/1937	Fagerburg	98/2
2,224,433	12/1940	Holden	296/44
2,499,127	2/1950	Beard	296/44
2,550,619	4/1951	Sutherland	98/2
2,582,914	1/1952	Reed	296/44
2,723,155	11/1955	Fox	98/2.12

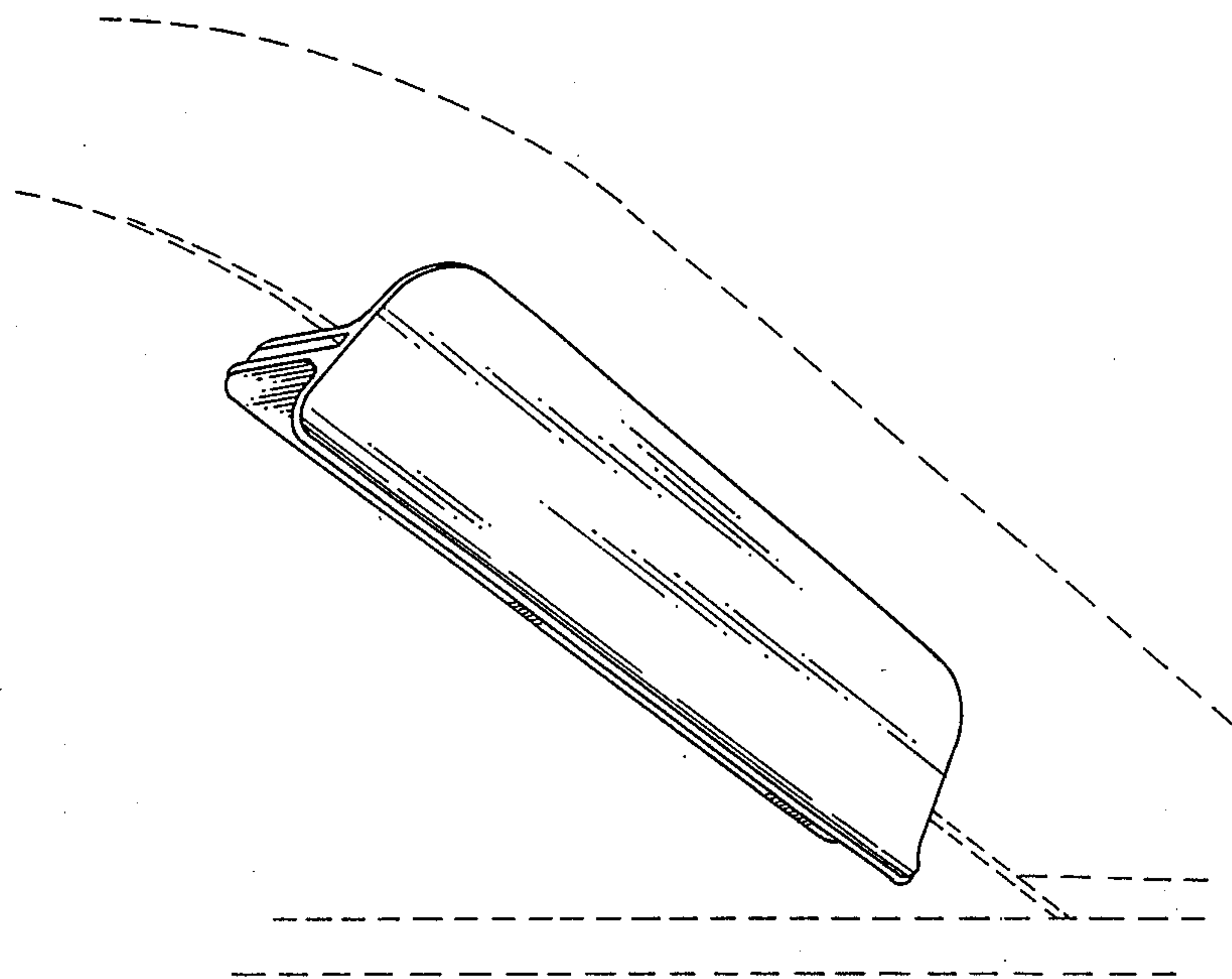

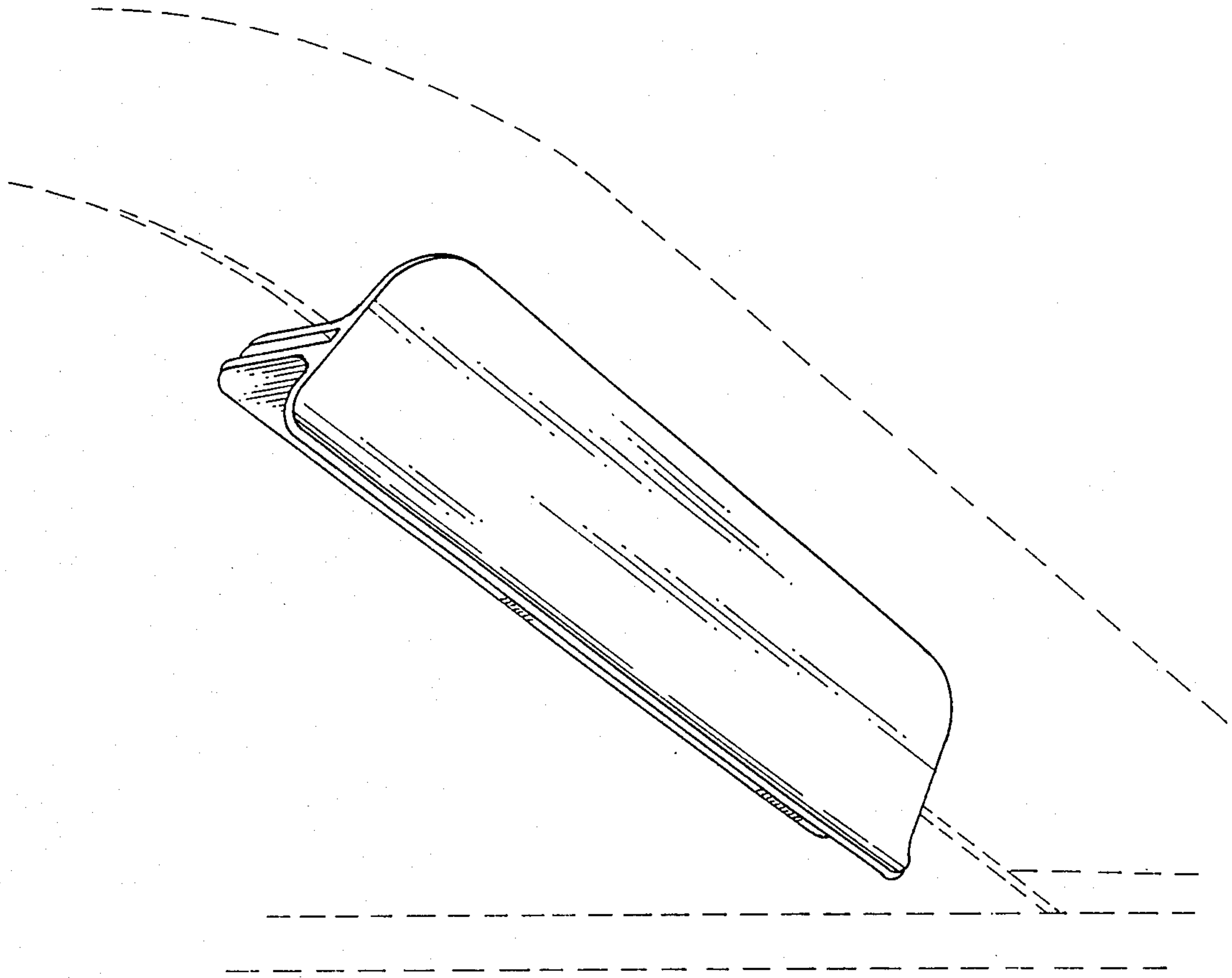

FIG. 1

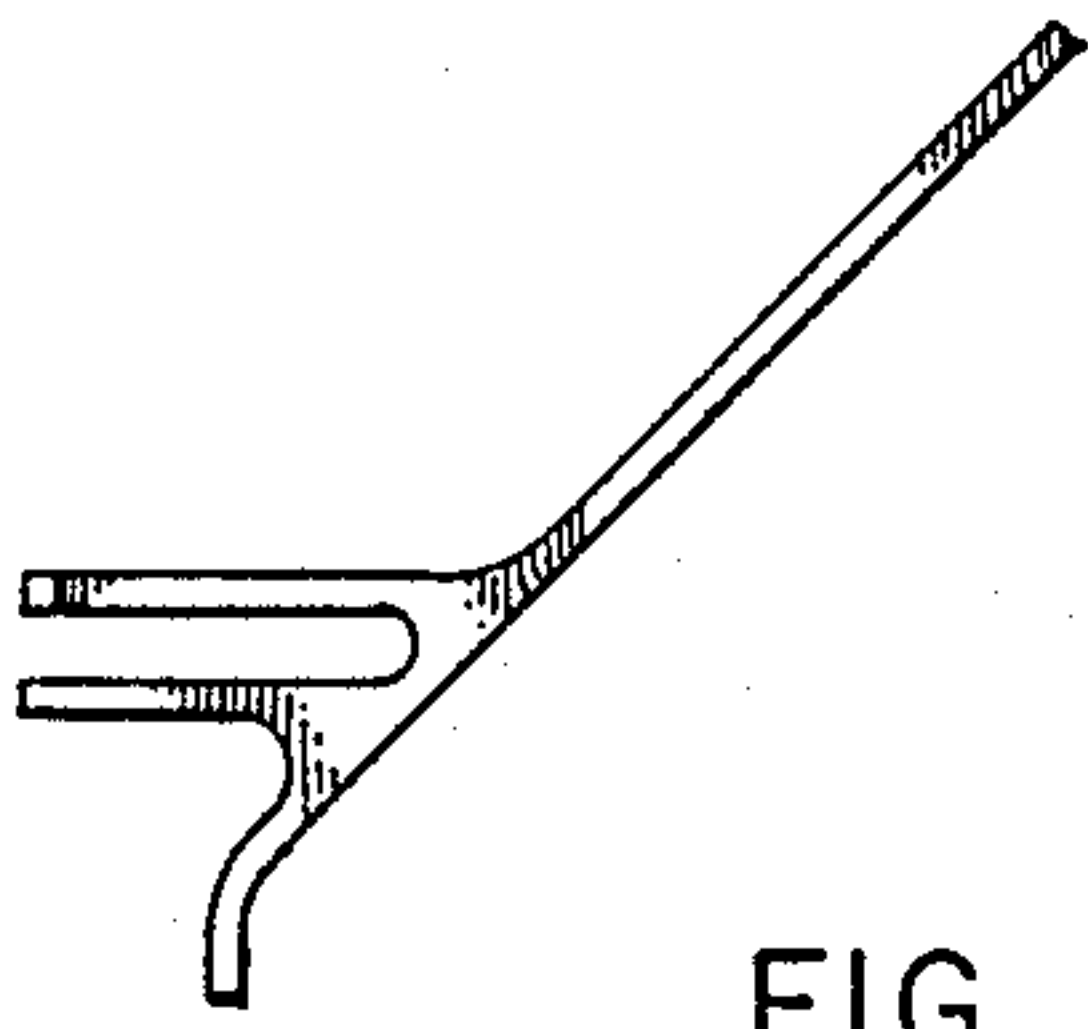

FIG. 2

FIG. 3

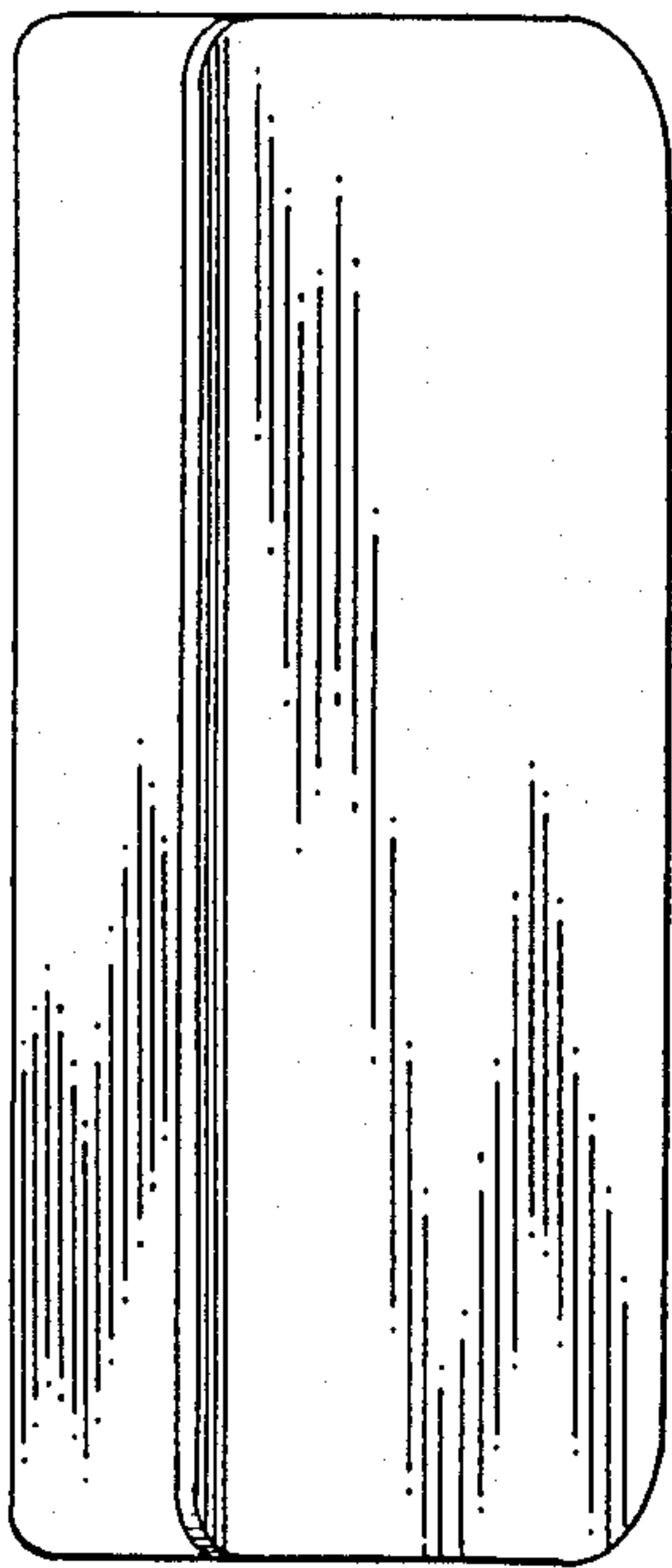

FIG. 4

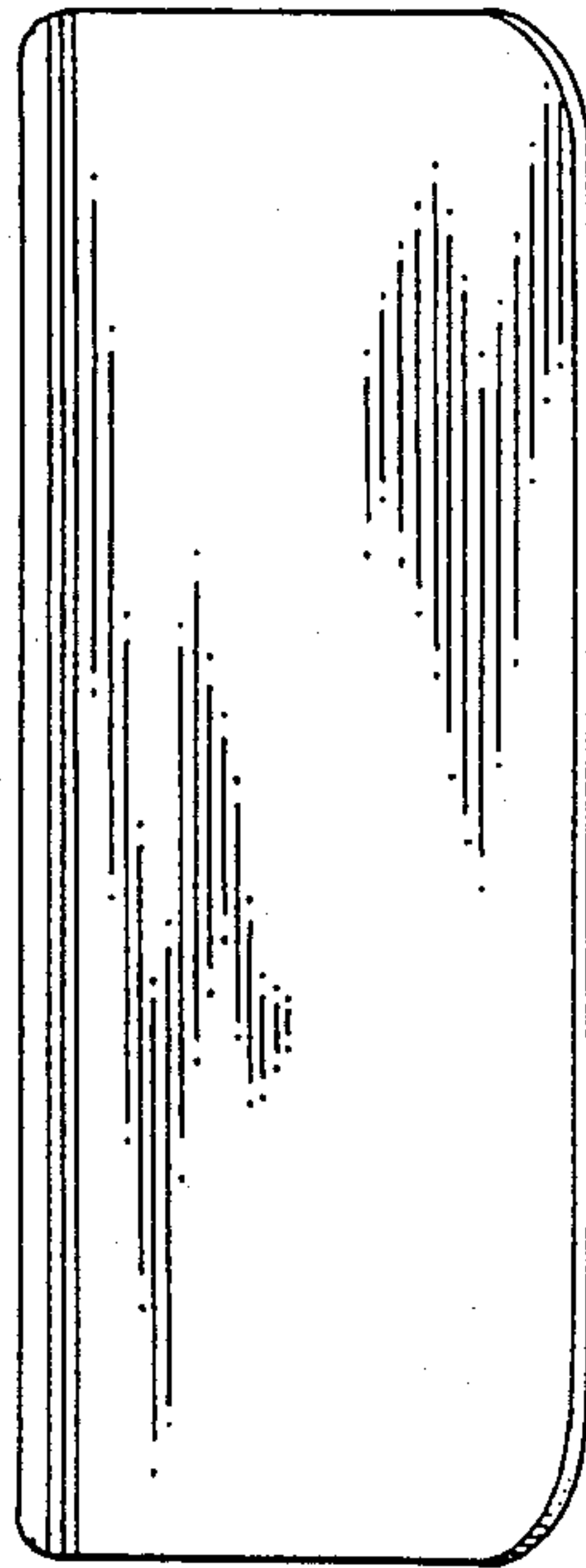

FIG. 5

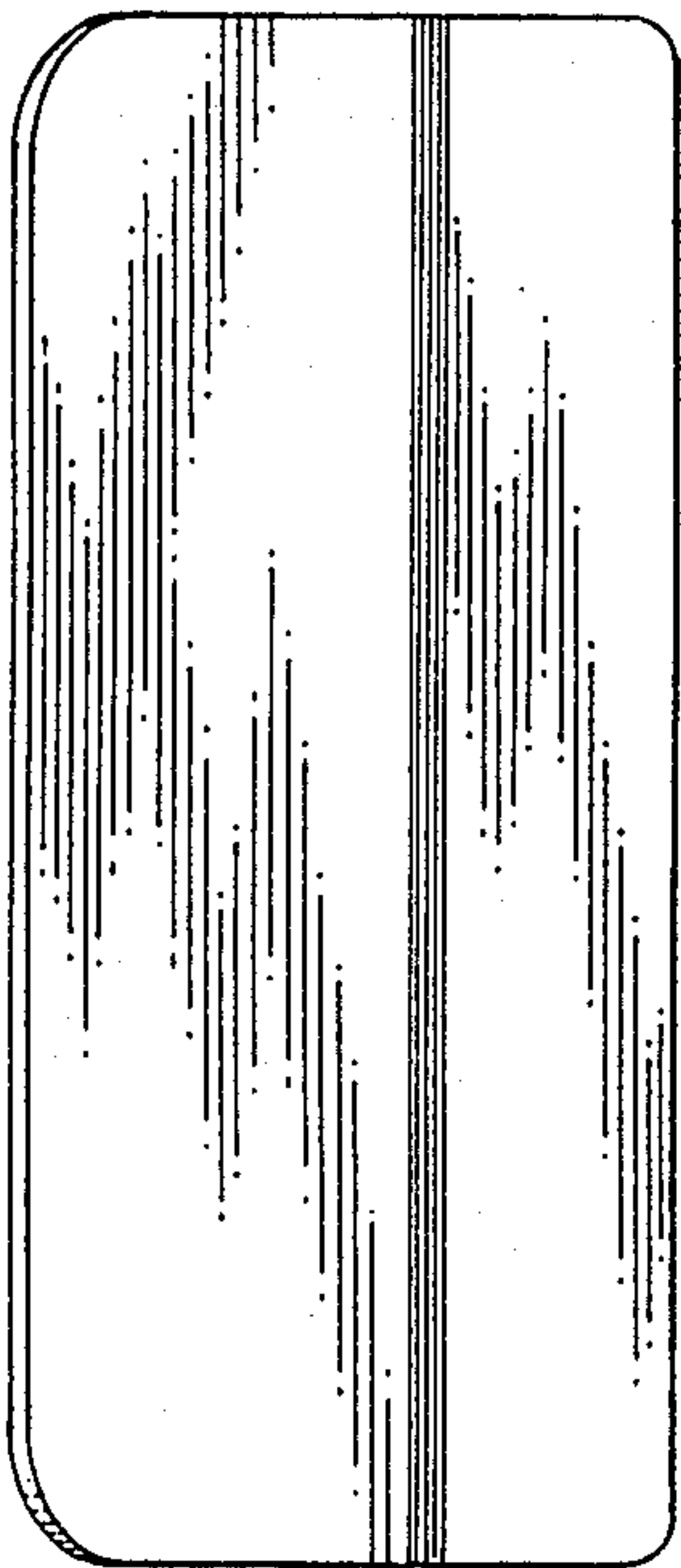

FIG. 6

