

[54] CONVERTIBLE WAGON AND SLED VEHICLE

[75] Inventors: Julie A. Shippee, 21 Grove St., Marshfield, Mass. 02050; Robert K. Little, Mt. Holly, N.J.

[73] Assignee: Julie A. Shippee, Greenwich, Conn.

[**] Term: 14 Years

[21] Appl. No.: 916,029

[22] Filed: Oct. 6, 1986

[52] U.S. Cl. D12/6; D12/9; D34/17

[58] Field of Search D12/6, 9; 280/7.14, 280/7.12, 16, 12 R, 19, 12 C, 13, 22, 25, 28; D34/17, 19, 21

[56] References Cited

U.S. PATENT DOCUMENTS

D. 234,584	3/1975	Morris	D12/6
D. 286,218	10/1986	Friedman	D34/17
1,184,777	5/1916	Schluda	280/7.14
1,452,636	4/1923	Bowden	280/7.12
1,659,517	2/1928	Cornil	280/7.14
2,750,198	6/1956	Moore et al.	280/7.14
3,226,130	12/1965	Smith	280/22
4,114,913	9/1978	Newell et al.	280/7.14
4,291,891	9/1981	Blanchette	280/13
4,337,957	7/1982	Heine	280/7.14

OTHER PUBLICATIONS

Toys & Novelties, Mar. 1961, p. 444, Kal-Kiddi Baby Sled.

Primary Examiner—Wallace R. Burke

Assistant Examiner—Kay H. Chin

Attorney, Agent, or Firm—Mark P. Stone

[57] CLAIM

The ornamental design for a convertible wagon and sled vehicle, as shown and described.

DESCRIPTION

FIG. 1 is a perspective view of a convertible wagon and sled vehicle showing our new design, in the wagon mode embodiment;

FIG. 2 is a front elevational view of FIG. 1;

FIG. 3 is a rear elevational view of FIG. 1;

FIG. 4 is a right side elevational view of FIG. 1;

FIG. 5 is a left side elevational view of FIG. 1;

FIG. 6 is a top plan view of FIG. 1;

FIG. 7 is a bottom plan view of FIG. 1;

FIG. 8 is a perspective view of a convertible wagon and sled vehicle, in the sled mode embodiment;

FIG. 9 is a front elevational view of FIG. 8;

FIG. 10 is a rear elevational view of FIG. 8;

FIG. 11 is a right side elevational view of FIG. 8;

FIG. 12 is a left side elevational view of FIG. 8;

FIG. 13 is a top plan view of FIG. 8; and

FIG. 14 is a bottom plan view of FIG. 8.

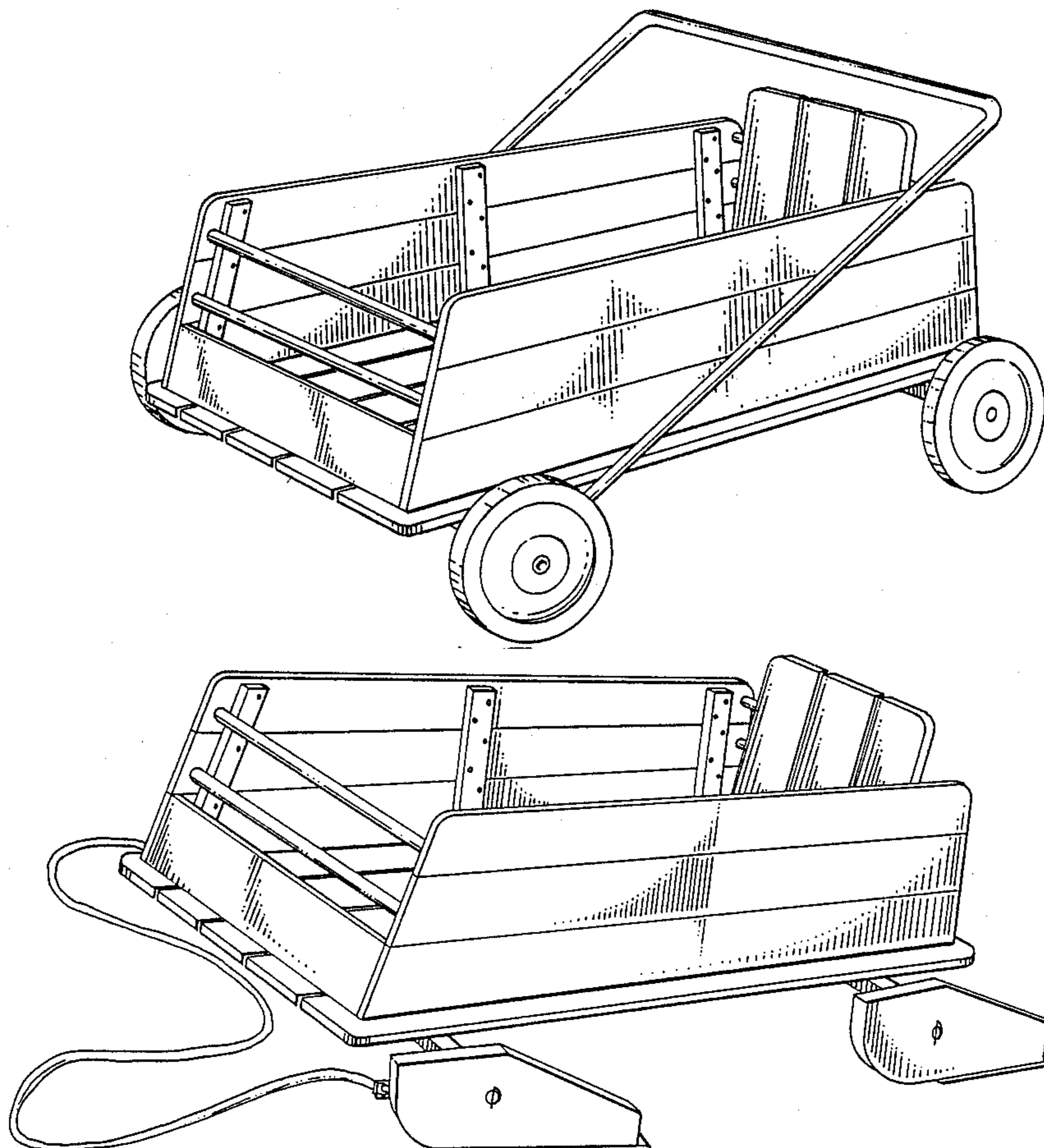

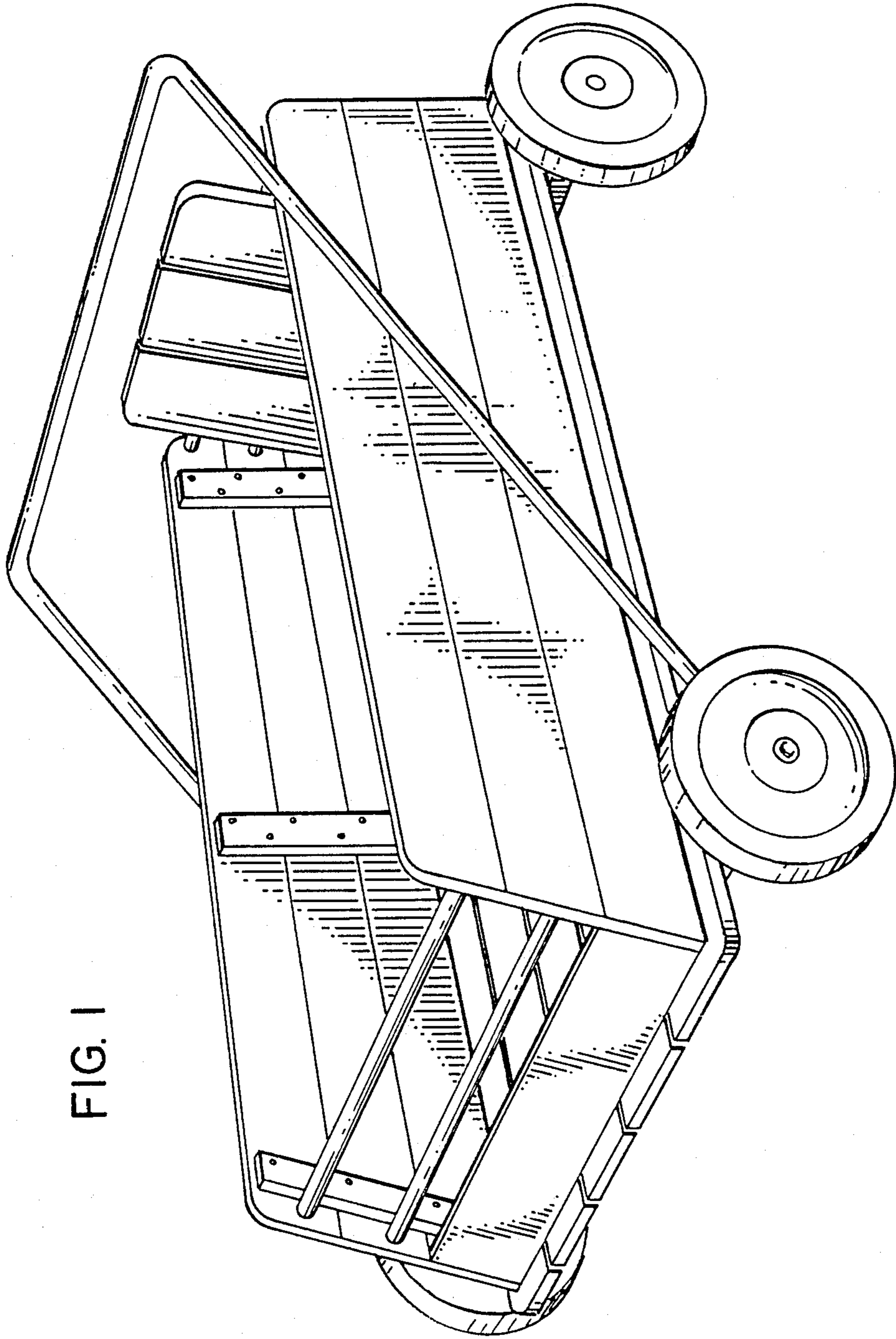

FIG. 1

FIG. 2

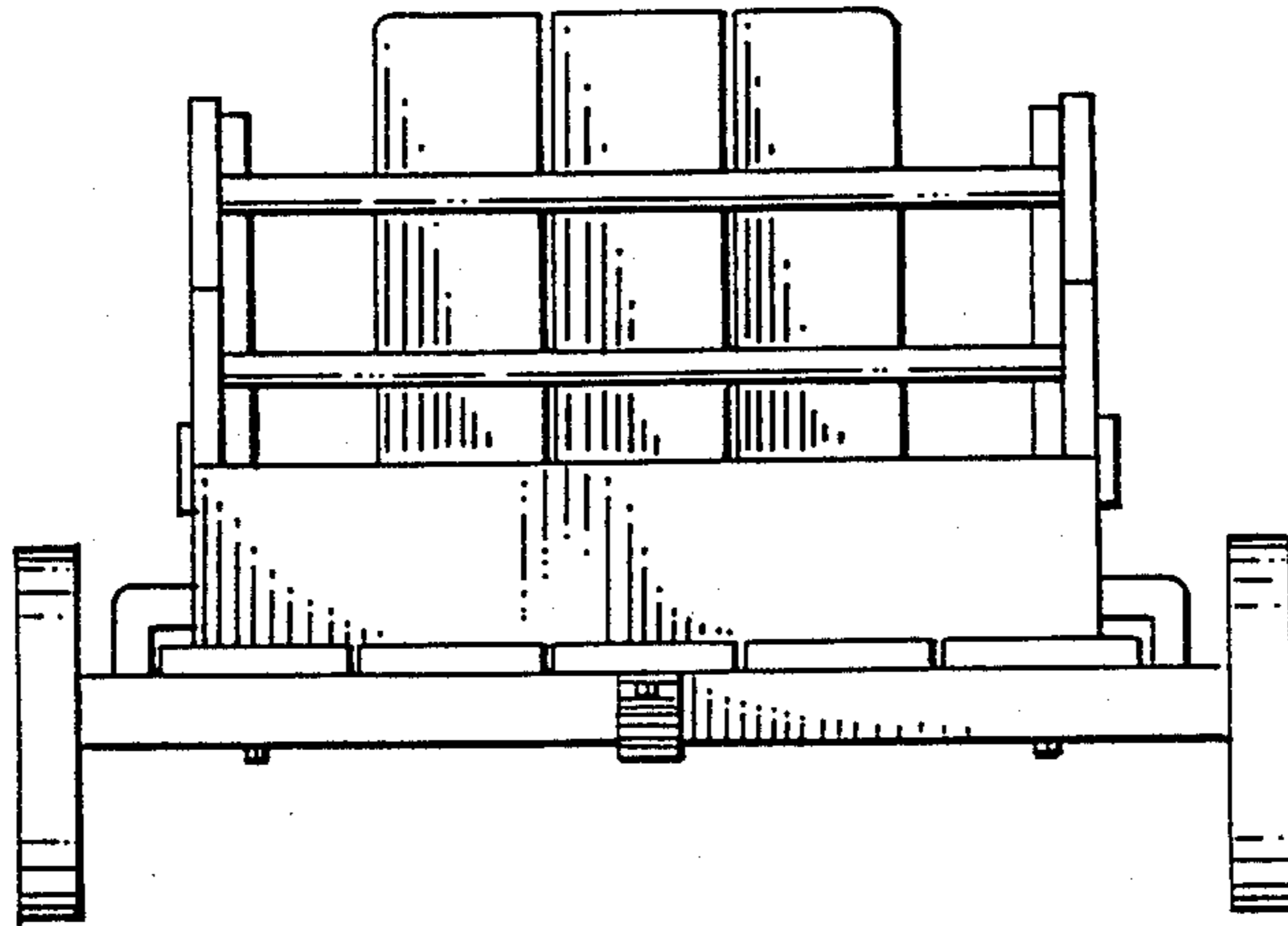

FIG. 3

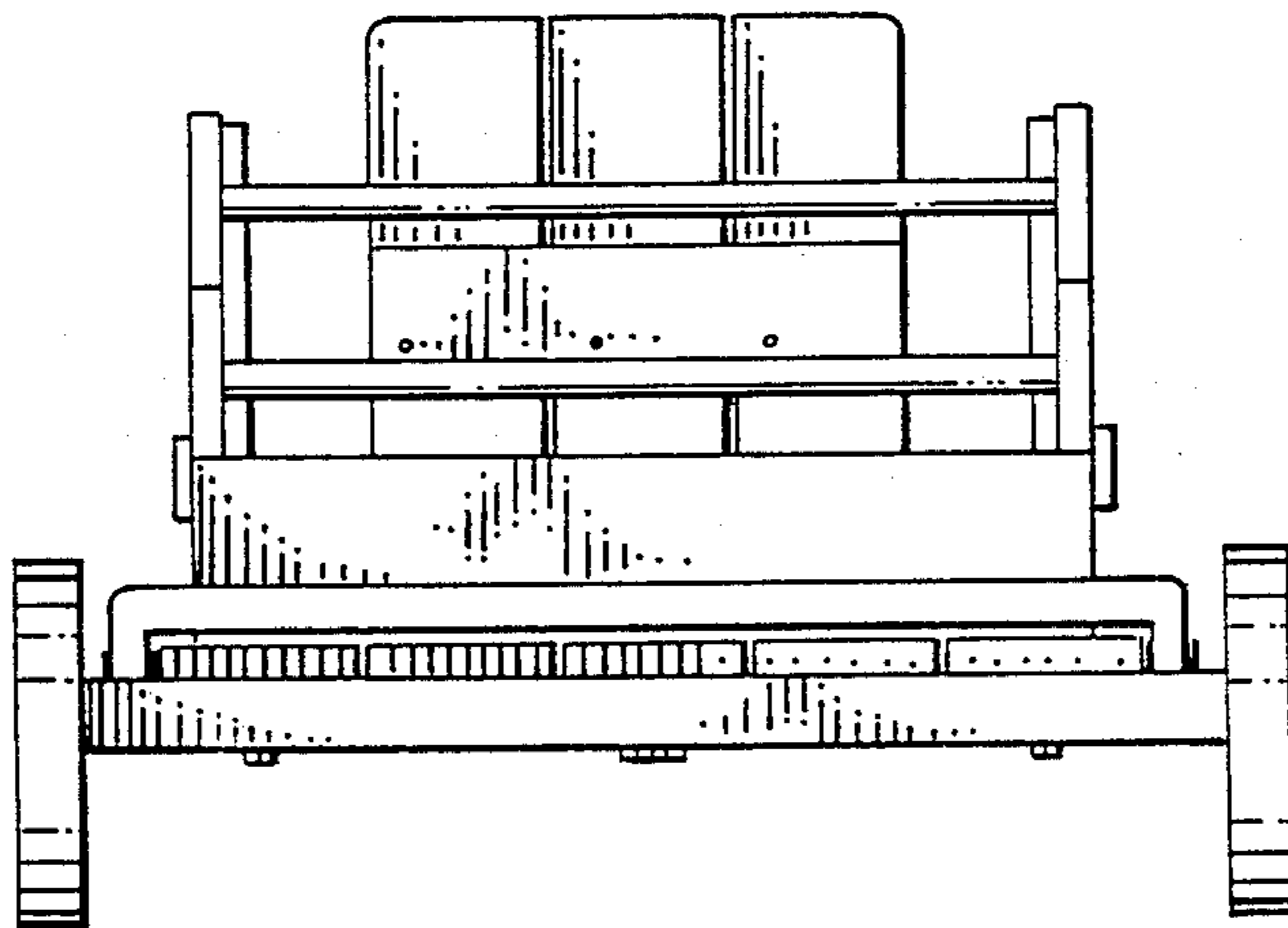

FIG. 4

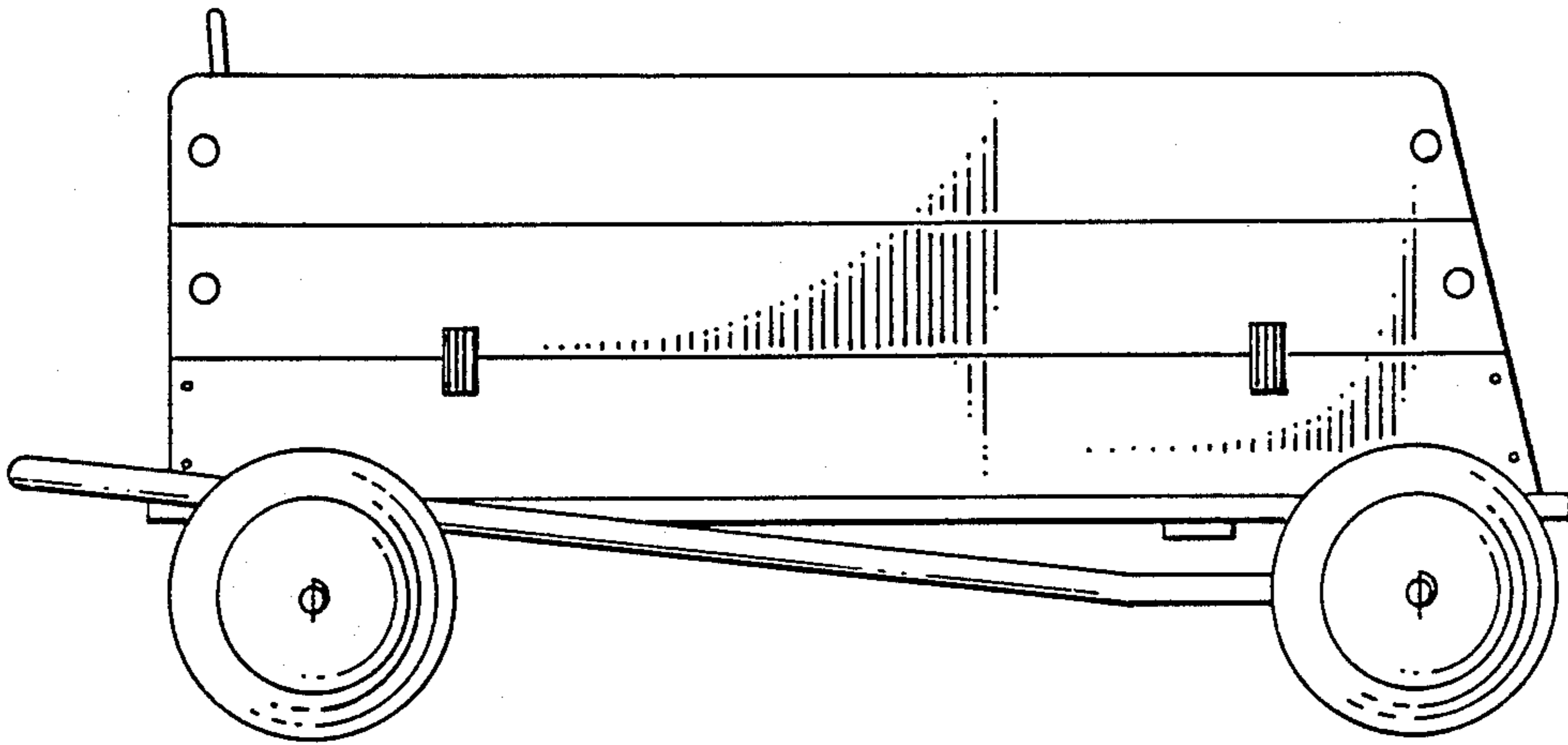

FIG. 5

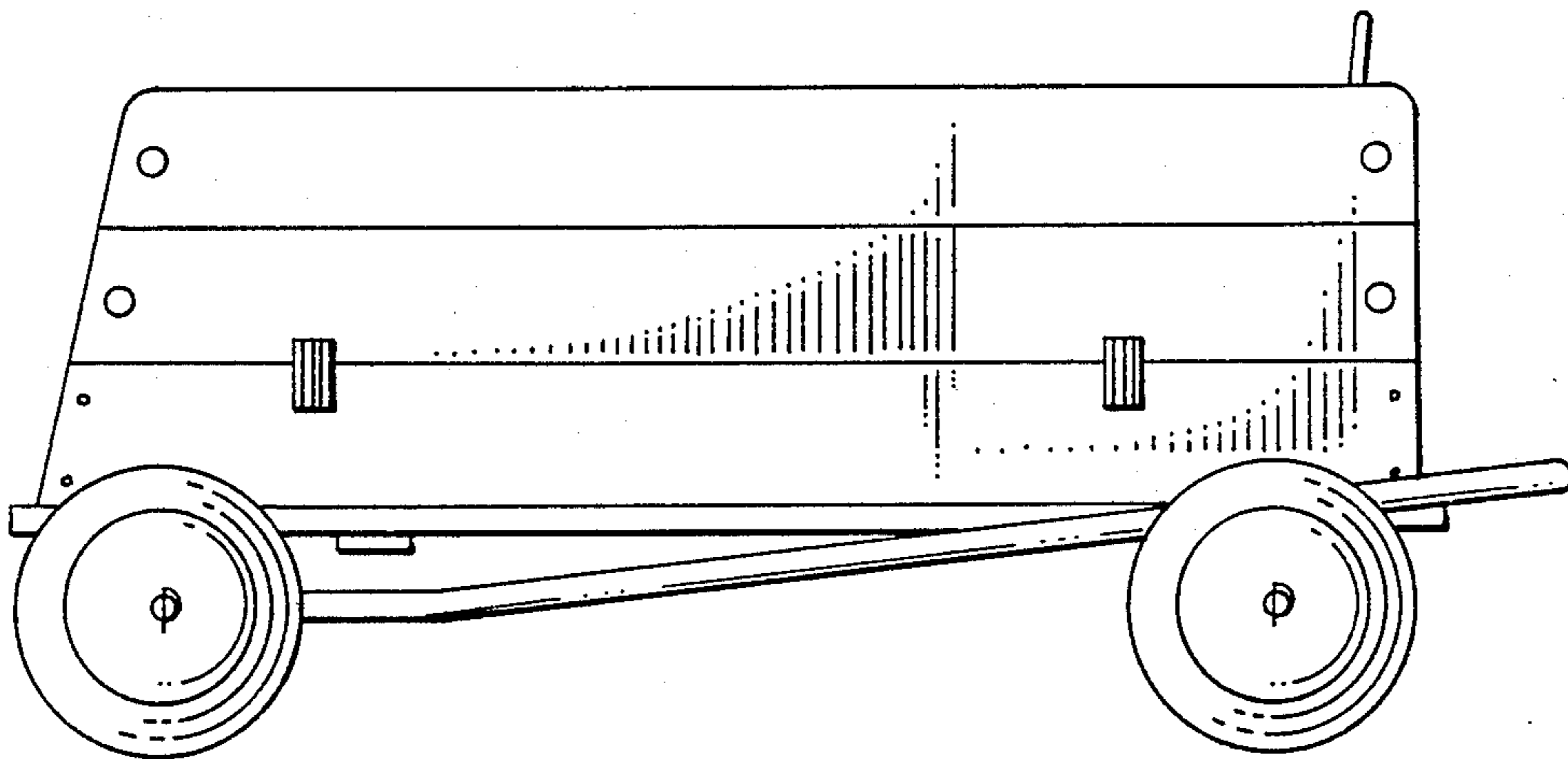

FIG. 6

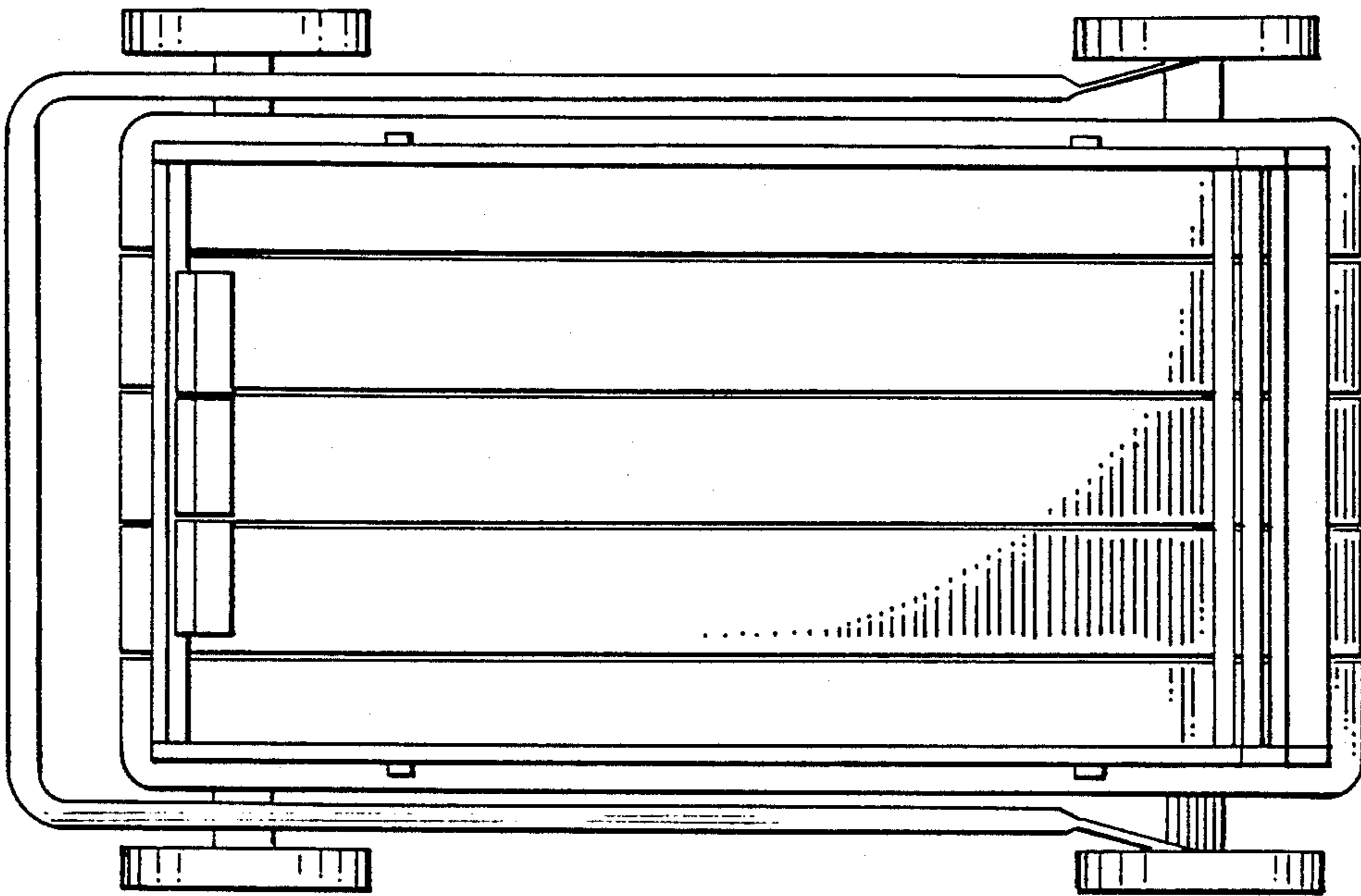

FIG. 7

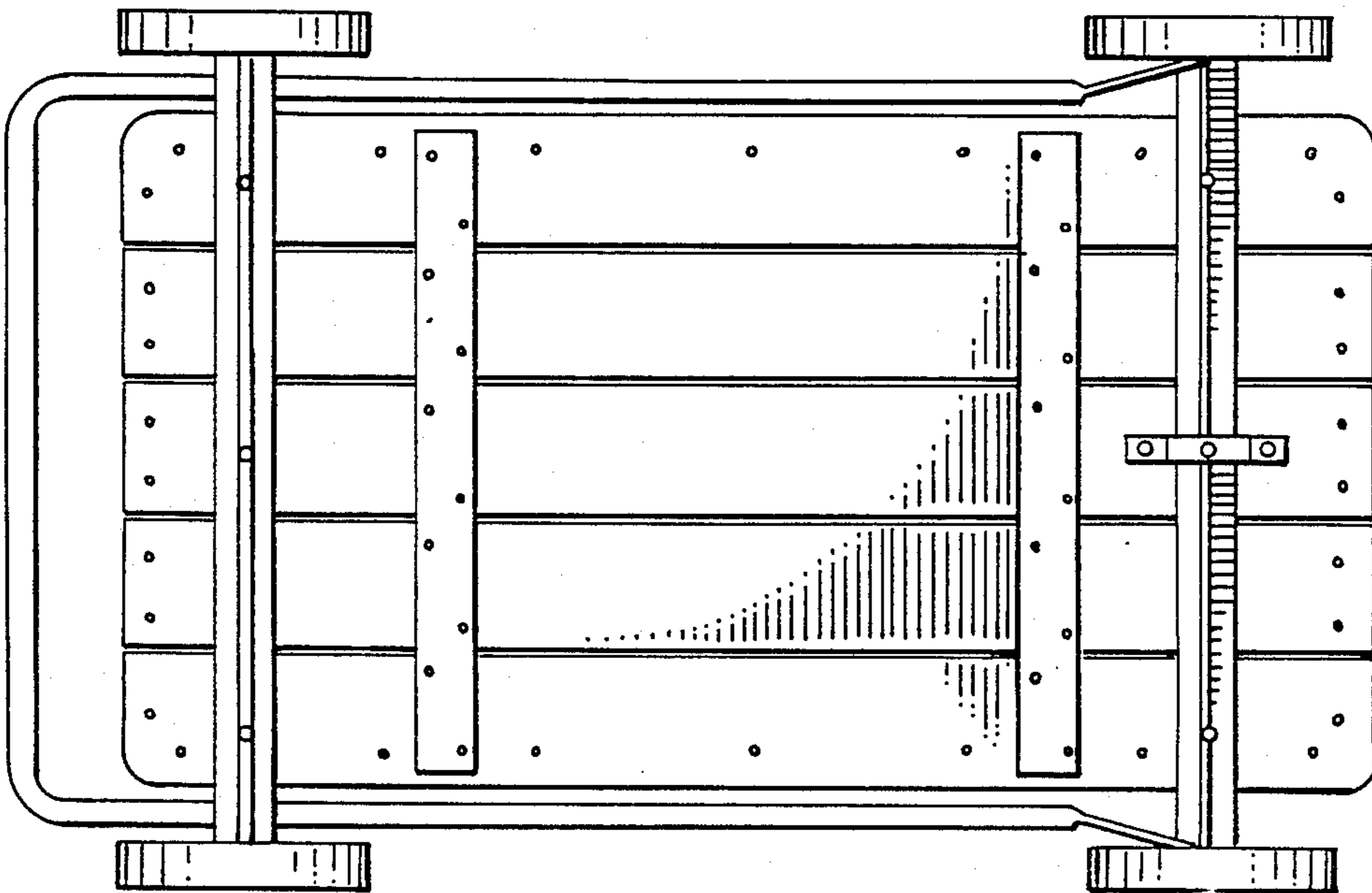

FIG. 8

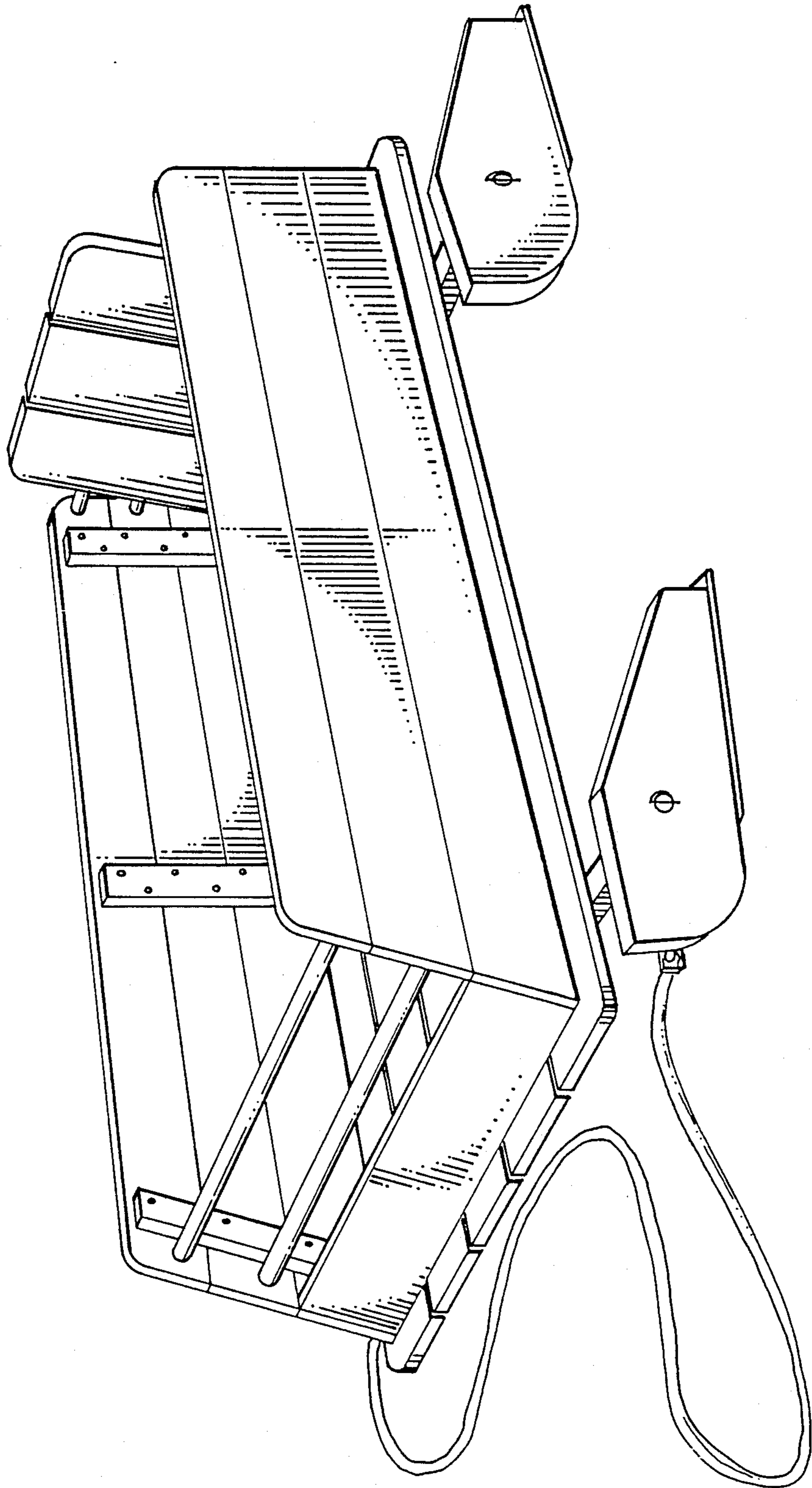

FIG. 9

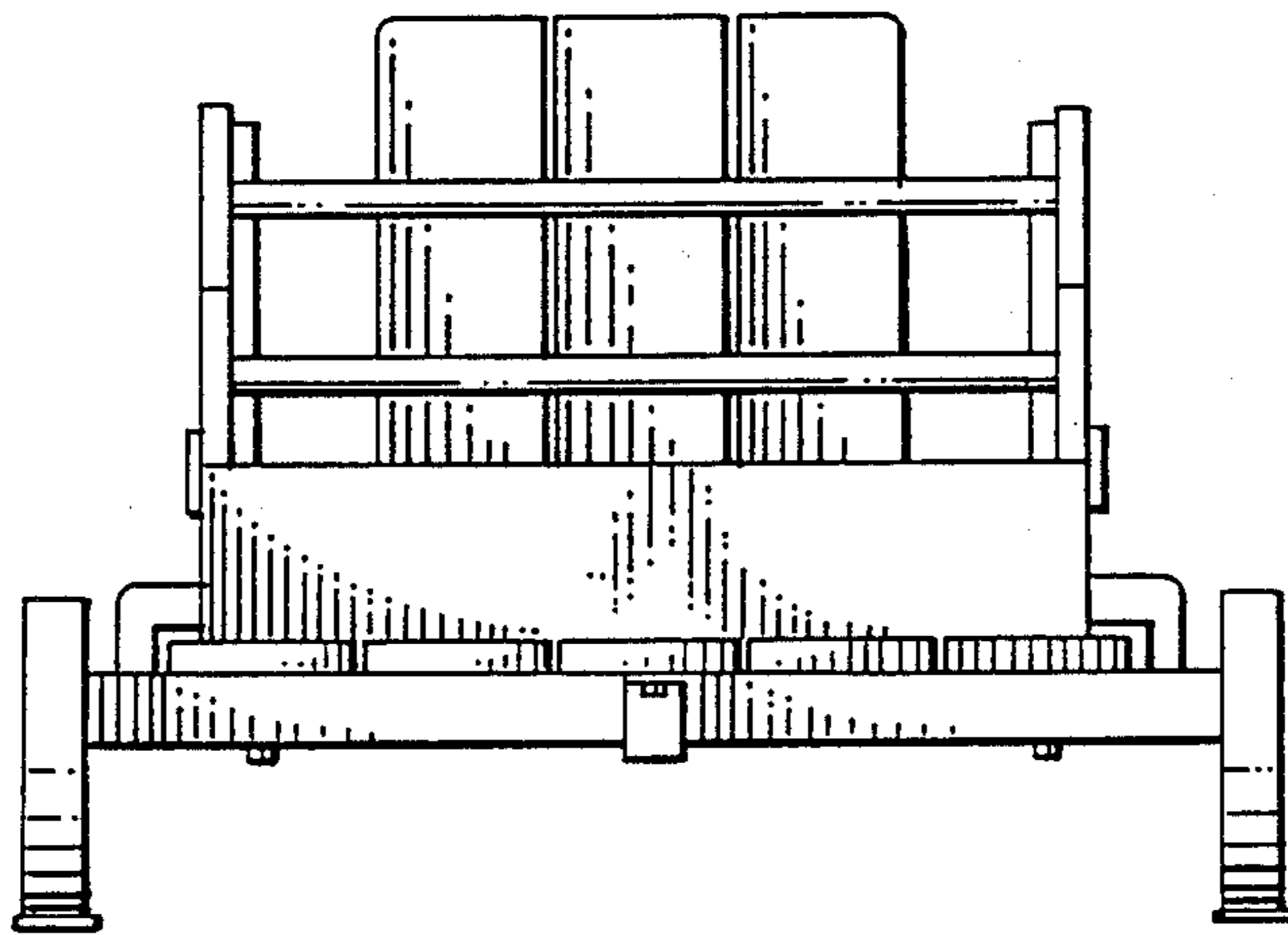

FIG. 10

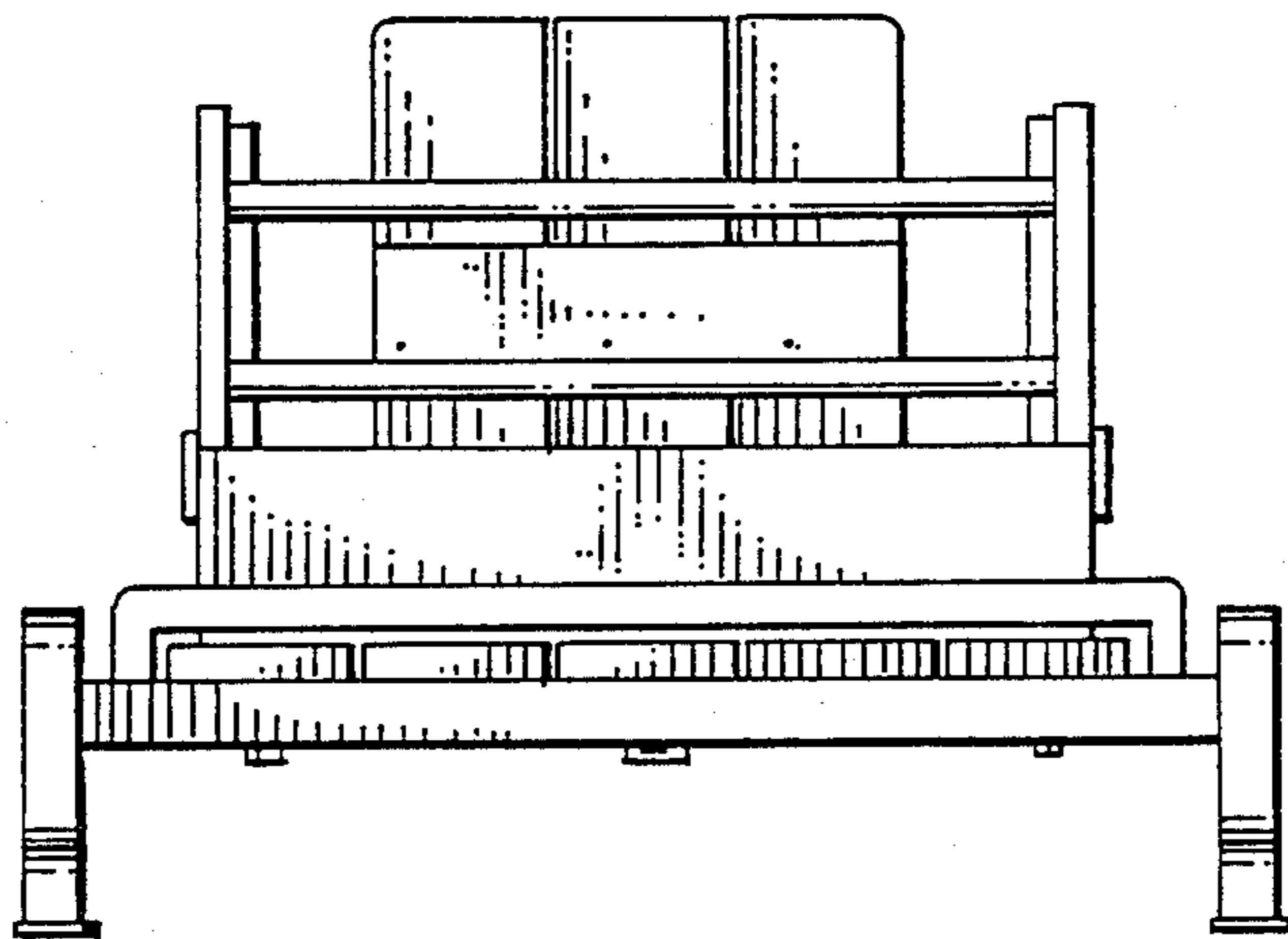

FIG. II

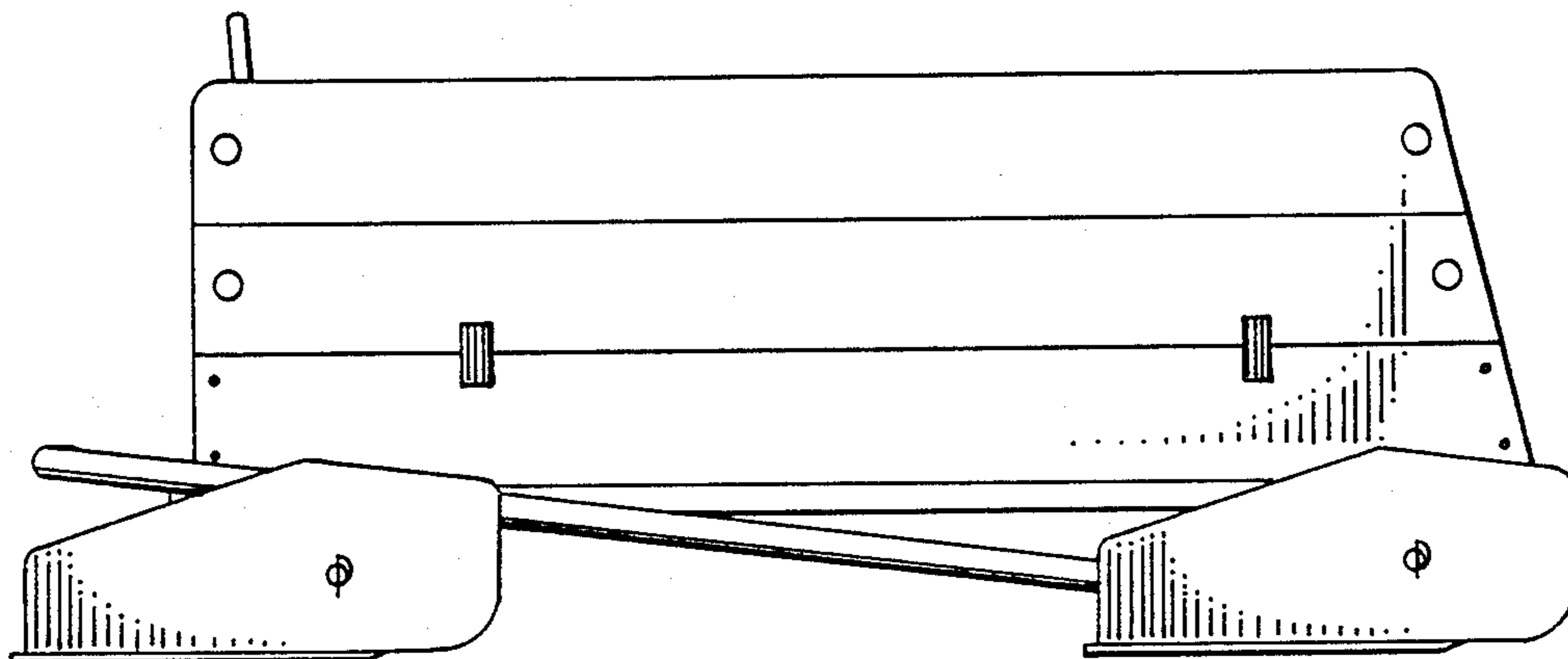

FIG. 12

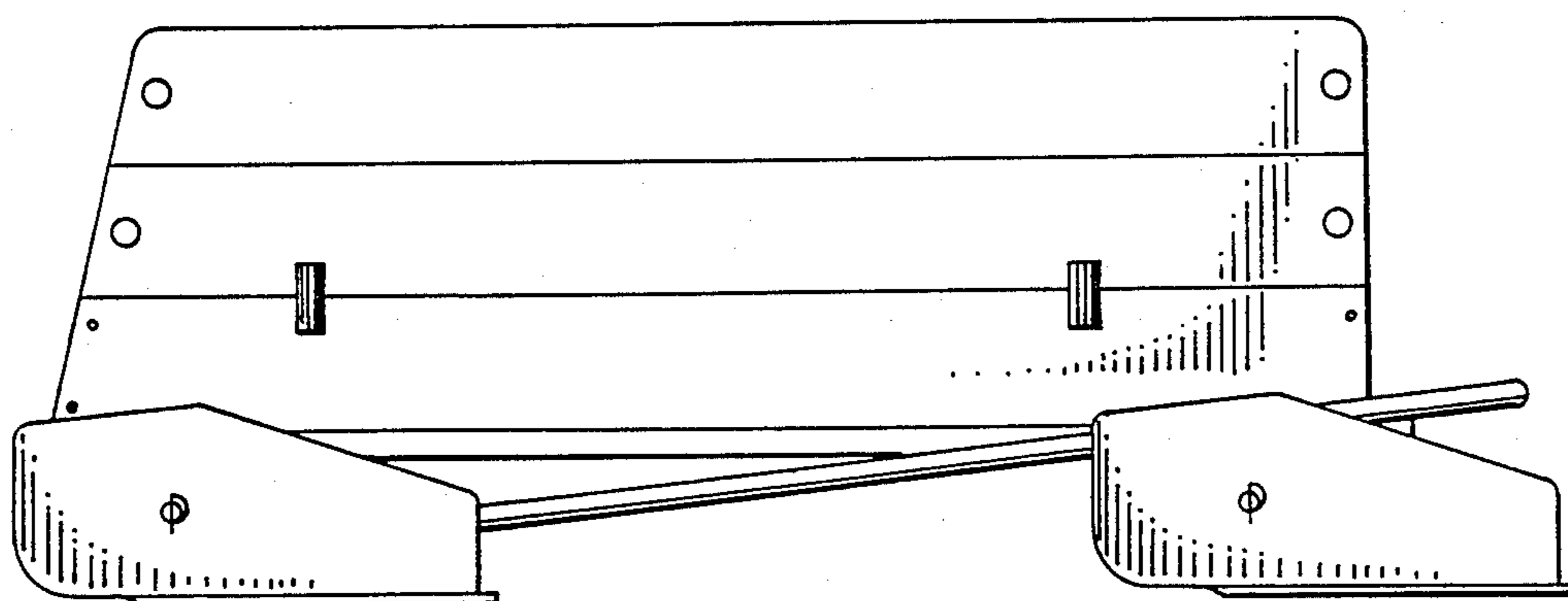

FIG. 13

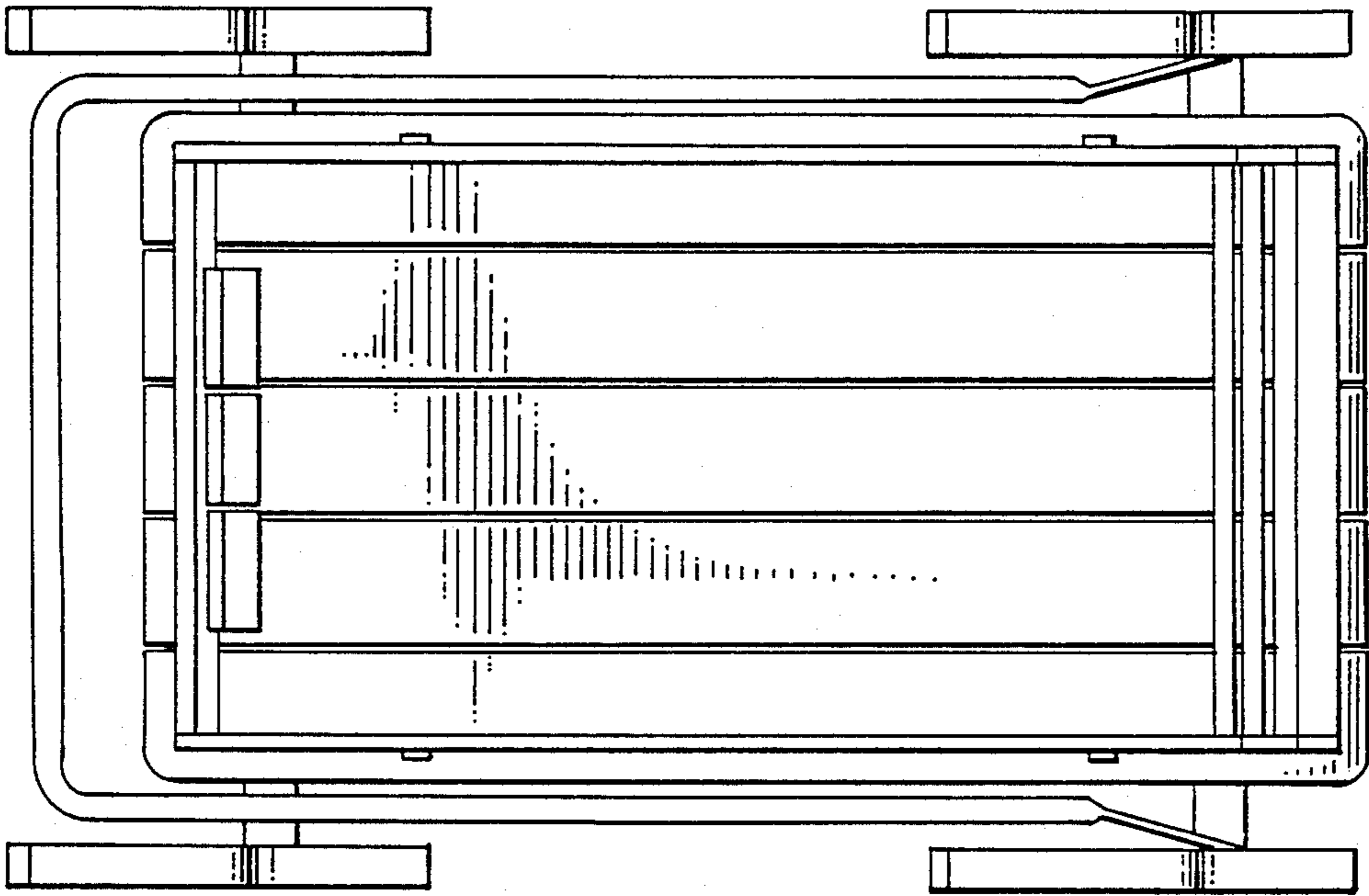

FIG. 14

