

# United States Patent [19]

Takahashi et al.

[11] Patent Number: Des. 302,853

[45] Date of Patent: \*\* Aug. 15, 1989

[54] FINNED HEAT EXCHANGER FOR ELECTRONIC EQUIPMENT

[75] Inventors: Nobuyoshi Takahashi, Kadoma; Yoshihiko Yamamoto, Itami; Masao Fujii, Takarazuka; Yu Seshimo, Amagasaki, all of Japan

[73] Assignee: Mitsubishi Denki Kabushiki Kaisha, Tokyo, Japan

[\*\*] Term: 14 Years

[21] Appl. No.: 773,614

[22] Filed: Sep. 9, 1985

### [30] Foreign Application Priority Data

Apr. 24, 1985 [JP] Japan ..... 16900/1985

[52] U.S. Cl. .... D23/386; D23/314

[58] Field of Search ..... D23/386, 314, 323, 380, D23/386; 165/164-167, 185, 140, 150-155, 179, 181, 183, 80.1, 80.2, 80.3; D13/23; 174/16 HS; 357/81; 361/386

### [56] References Cited

#### U.S. PATENT DOCUMENTS

D. 266,082	9/1982	Asanuma .....	D13/23
3,163,207	12/1964	Schultz .....	D13/23 X
3,645,330	2/1972	Albright et al. ....	165/181 X
3,687,194	8/1972	Schöll .....	165/181 X

#### FOREIGN PATENT DOCUMENTS

5661	1/1979	Japan .	
0056598	4/1980	Japan .....	165/151
15628	of 1909	United Kingdom .....	165/181

*Primary Examiner*—Susan J. Lucas  
*Attorney, Agent, or Firm*—Oblon, Spivak, McClelland, Maier & Neustadt

### [57] CLAIM

The ornamental design for a finned heat exchanger for electronic equipment, as shown and described.

### DESCRIPTION

FIG. 1 is a front view of a finned heat exchanger for electronic equipment, showing our new design;  
FIG. 2 is a plan view thereof;  
FIG. 3 is a right side view thereof;  
FIG. 4 is a left side view thereof;  
FIG. 5 is a rear view thereof;  
FIG. 6 is a bottom view thereof; and  
FIG. 7 is a front perspective view thereof.

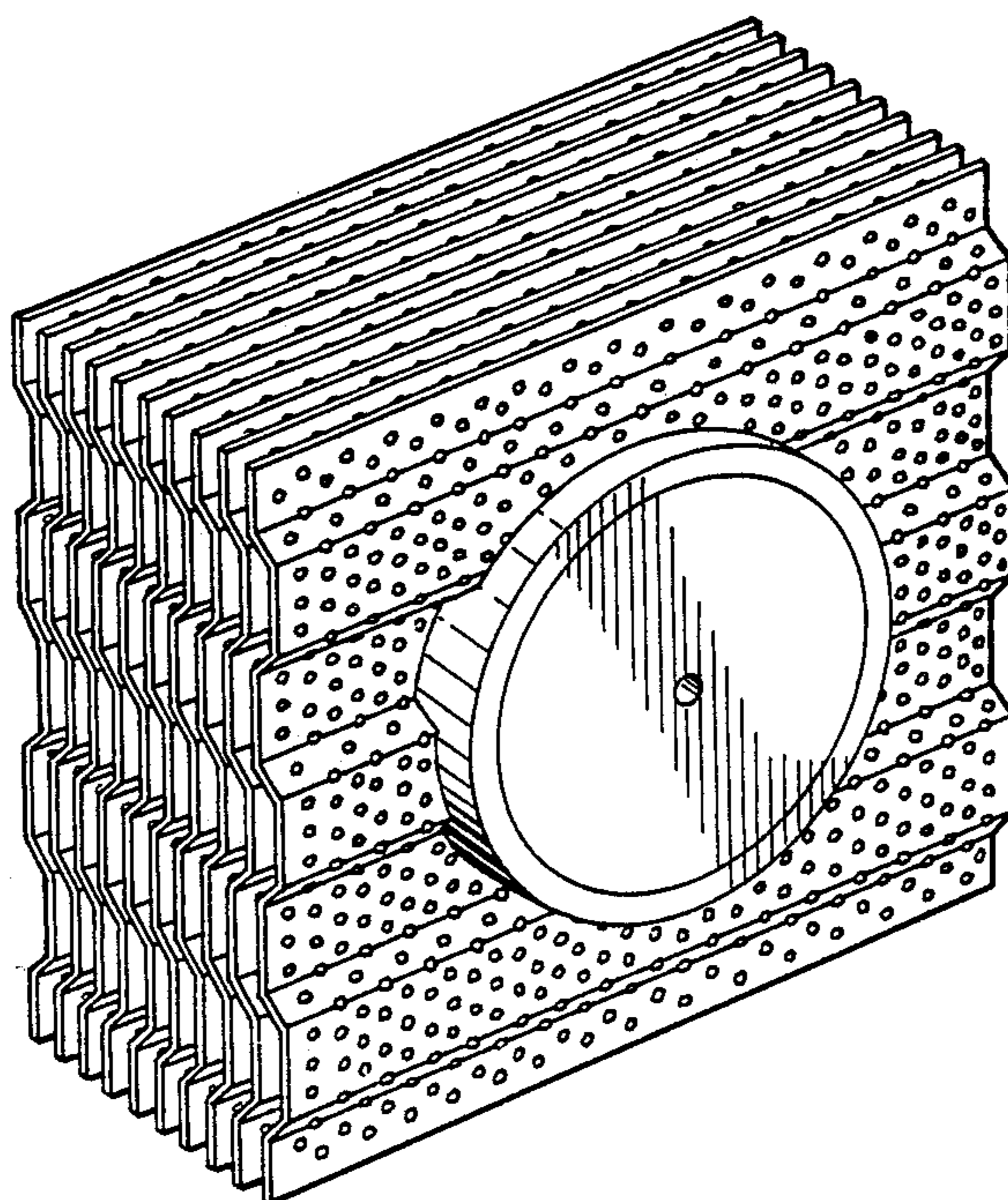

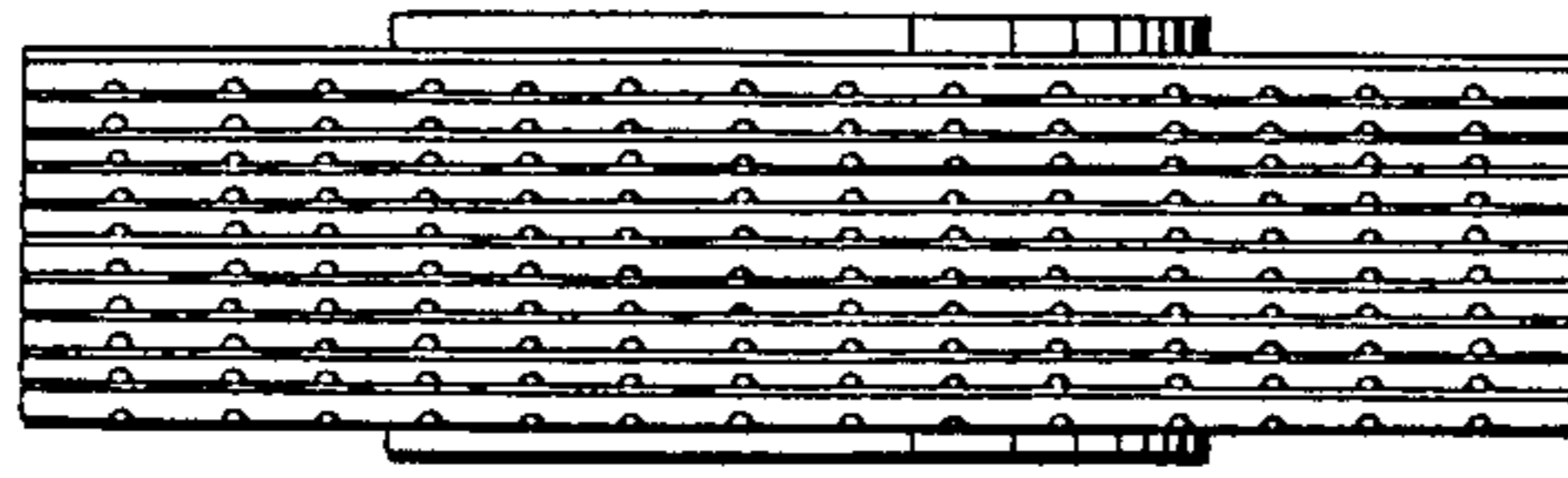

FIG. 2

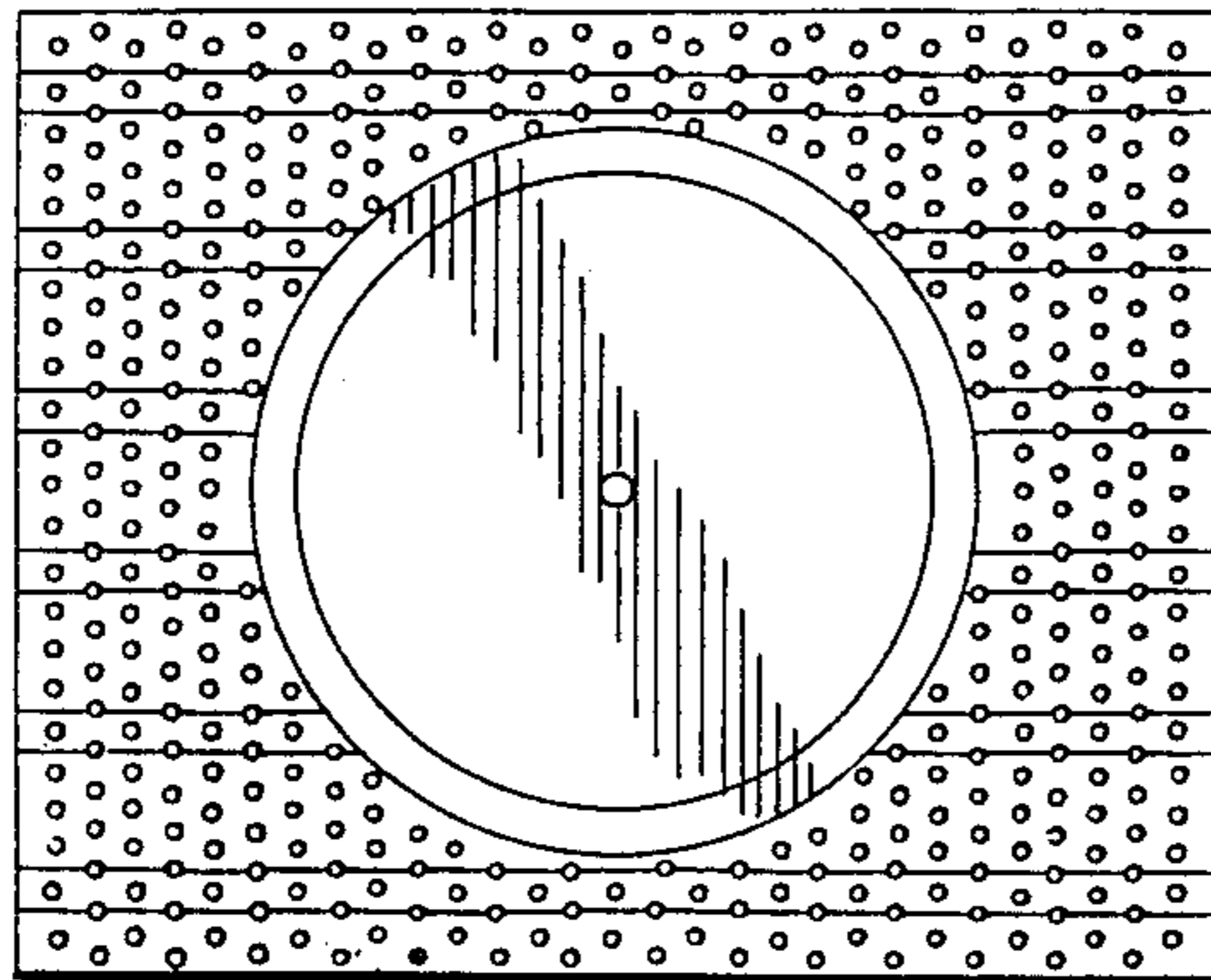

FIG. 1

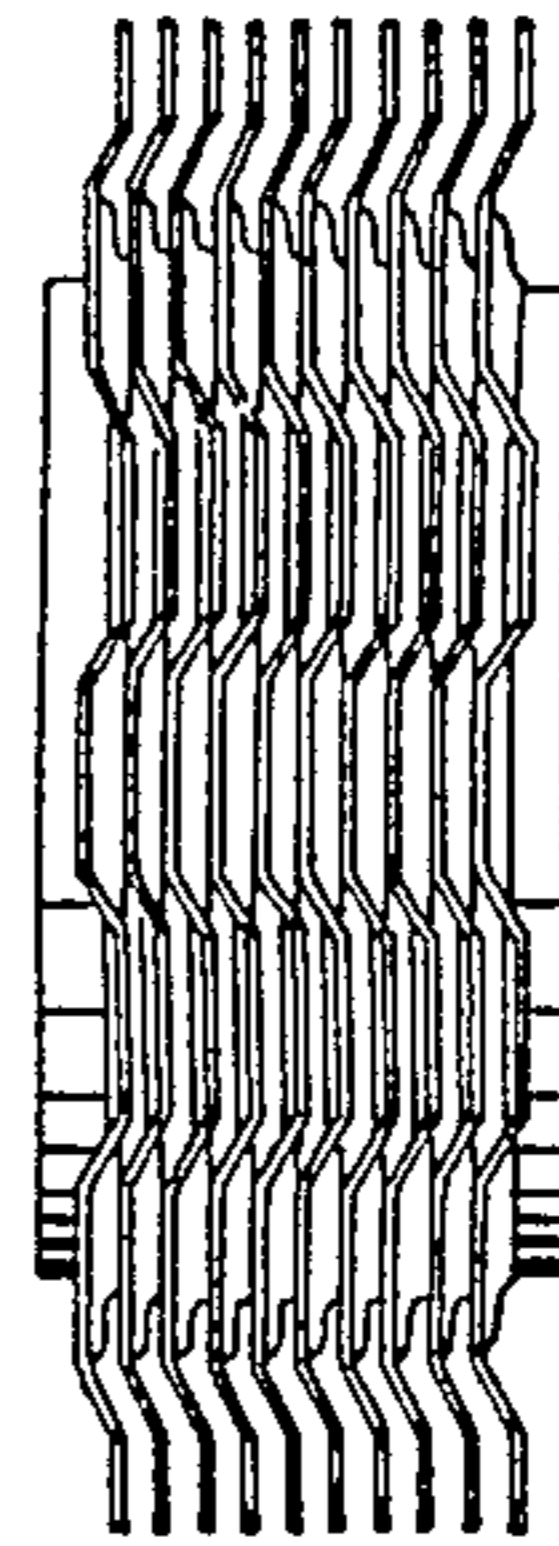

FIG. 3

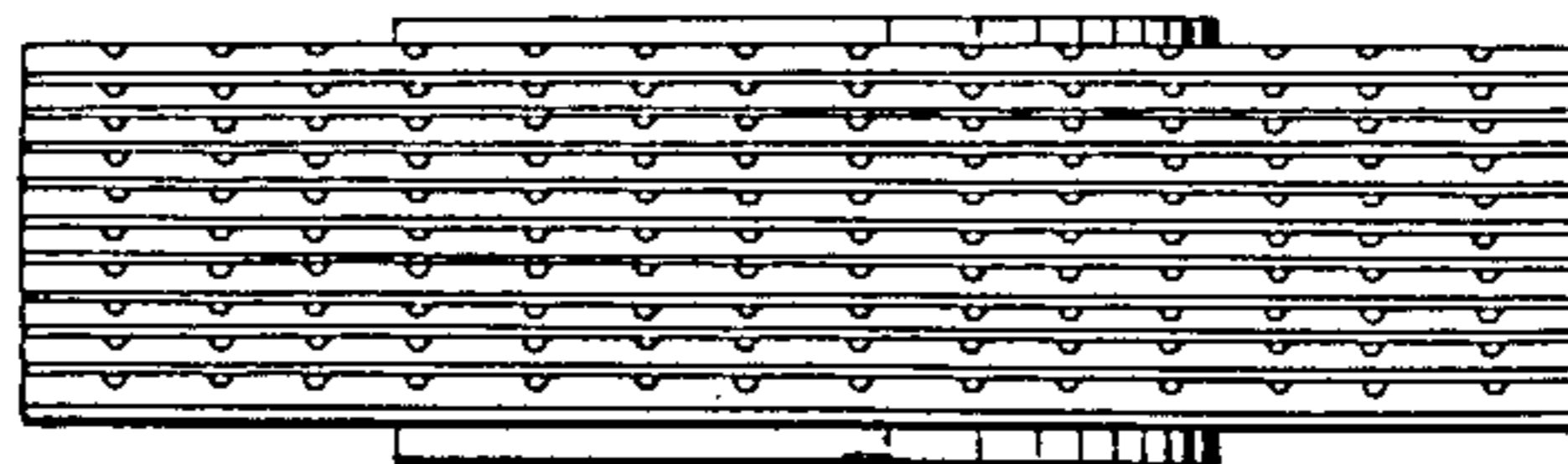

FIG. 6

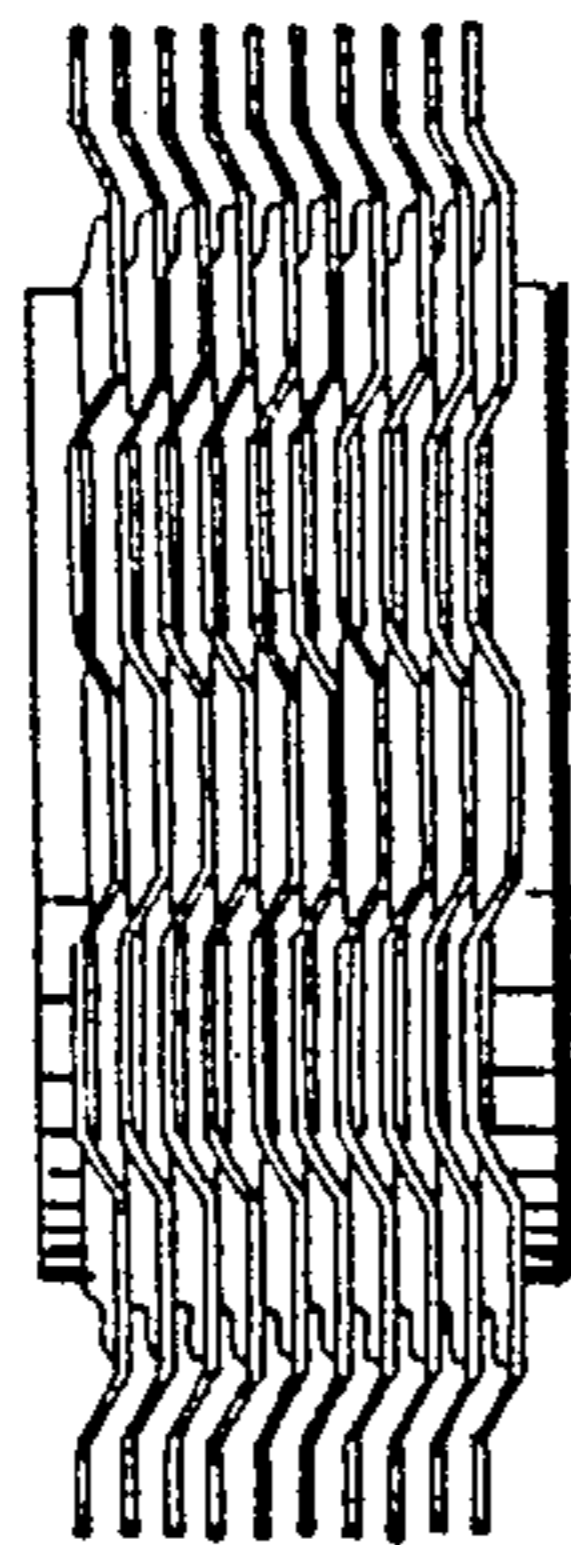

FIG. 4

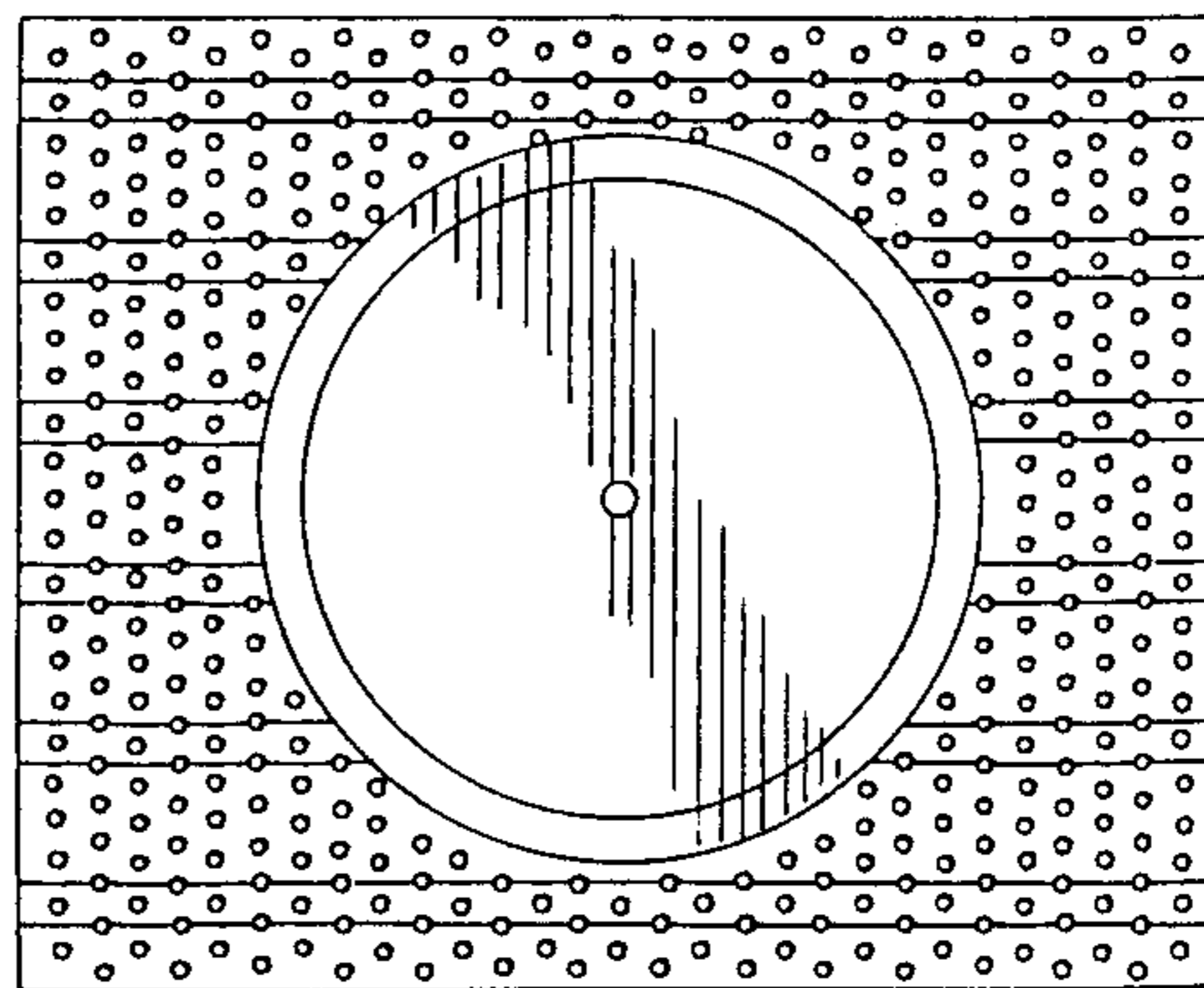

FIG. 5

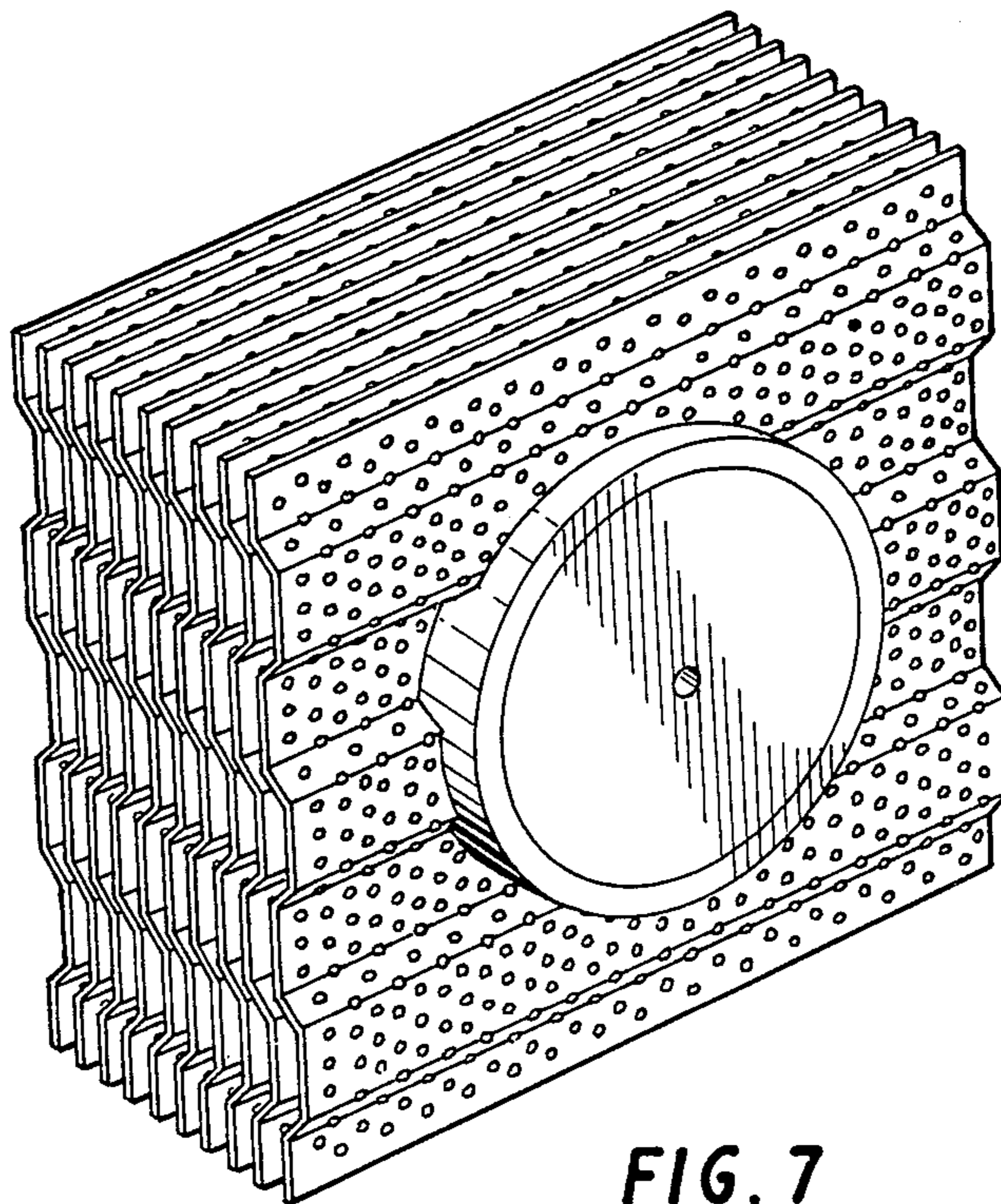

FIG. 7