

# United States Patent [19]

Riley et al.

[11] Patent Number: **Des. 302,825**

[45] Date of Patent: **\*\* Aug. 15, 1989**

[54] **GUITAR BODY AND NECK**

[76] Inventors: **Robert B. Riley; Robert E. Stefanski,**  
4879 Voltaire St., San Diego, Calif.  
92107

[\*\*] Term: **14 Years**

[21] Appl. No.: **842,427**

[22] Filed: **Mar. 10, 1986**

[52] U.S. Cl. .... **D17/14; D17/20**

[58] Field of Search ..... **D17/14, 15, 17, 18,**  
**D17/19, 20, 99; 84/1.16, 170, 267, 275, 291,**  
**293, 327**

[56] **References Cited**

**U.S. PATENT DOCUMENTS**

- D. 266,003 8/1982 Lieber ..... D17/14
- D. 269,788 7/1983 Le Blue ..... D17/14
- D. 292,217 10/1987 Giron, III ..... D17/14 X

- 3,769,871 11/1973 Cawthorn ..... 84/267 X
- 4,592,265 6/1986 Steinberger ..... 84/327

*Primary Examiner*—Bernard Ansher  
*Assistant Examiner*—Theodore M. Shooman  
*Attorney, Agent, or Firm*—Brown, Martin, Haller & McClain

[57] **CLAIM**

The ornamental design for a guitar body and neck, as shown and described.

**DESCRIPTION**

FIG. 1 is a top, front and left side perspective view of a guitar body and neck showing our new design; FIG. 2 is a bottom plan view thereof; FIG. 3 is a rear elevational view thereof, shown with the leg rest in an open position; FIG. 4 is a left side elevational view thereof; and FIG. 5 is a right side elevational view thereof.

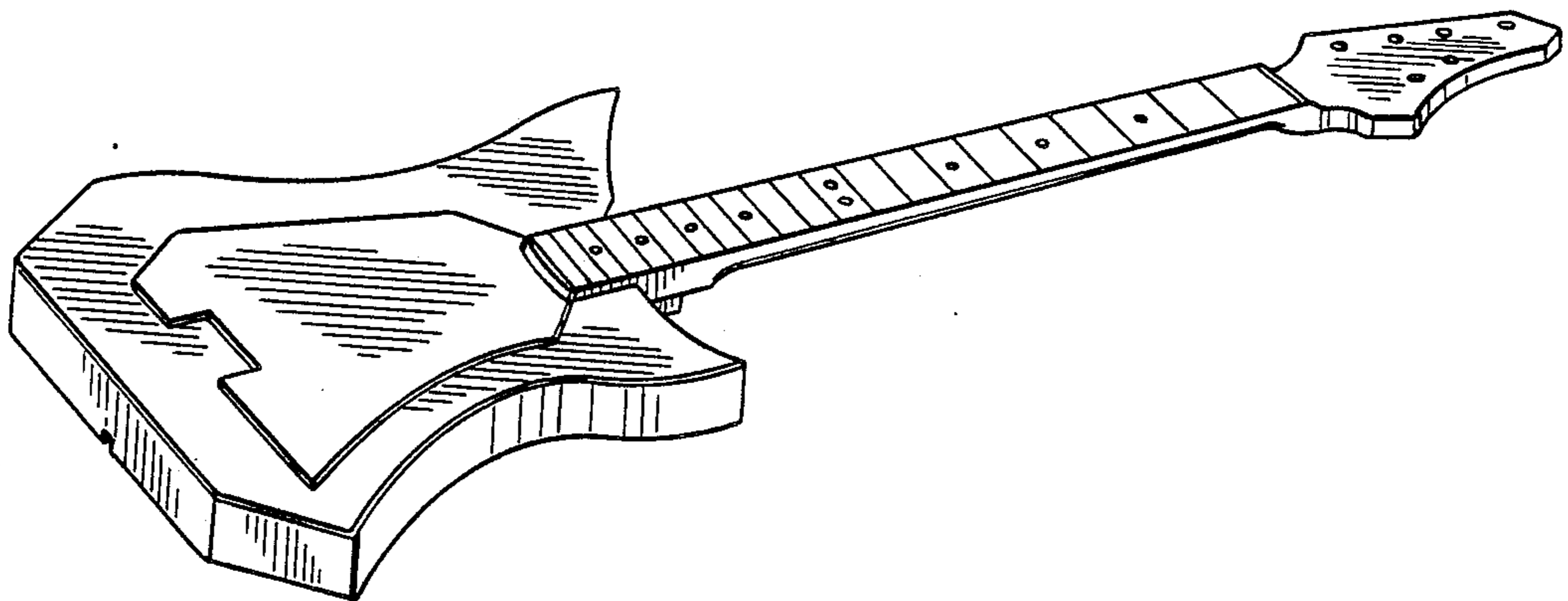

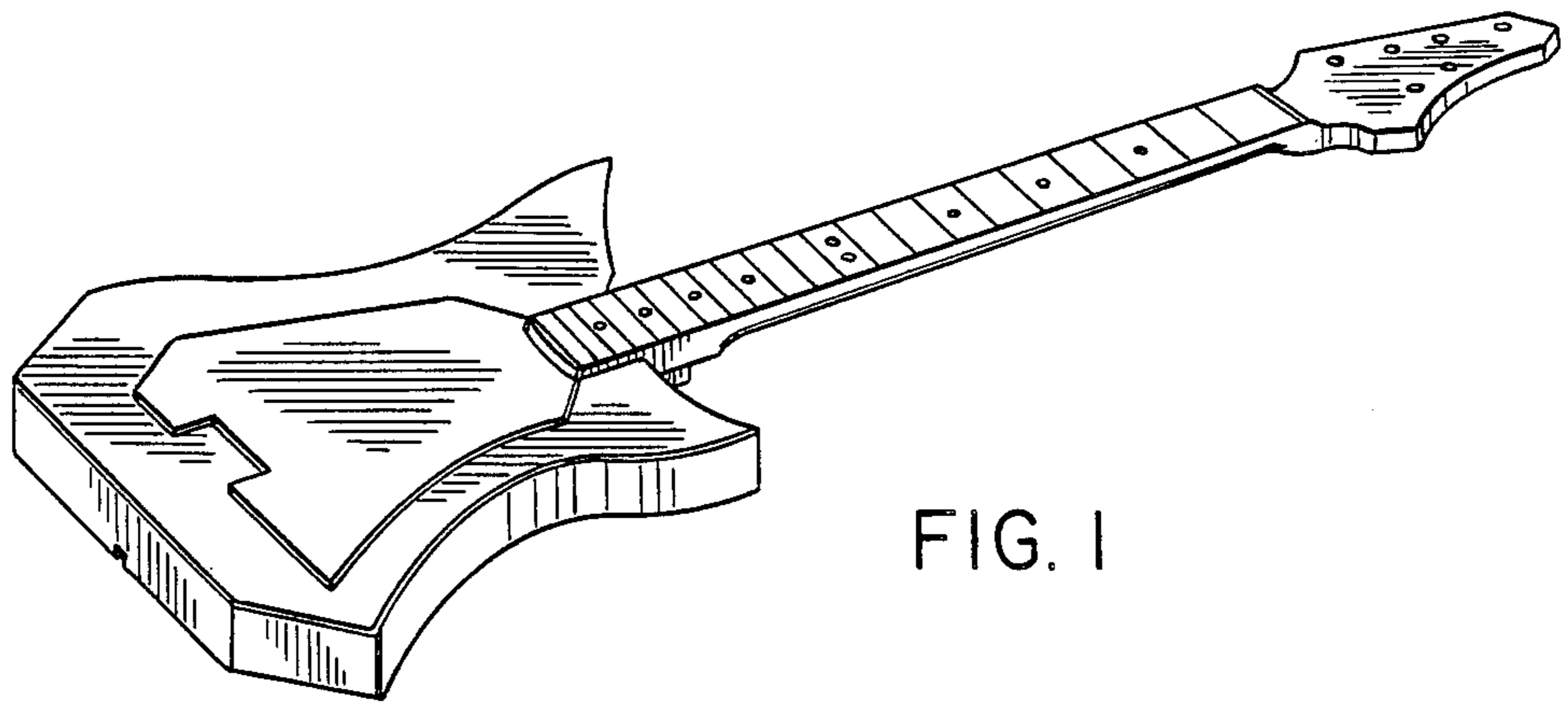

FIG. 1

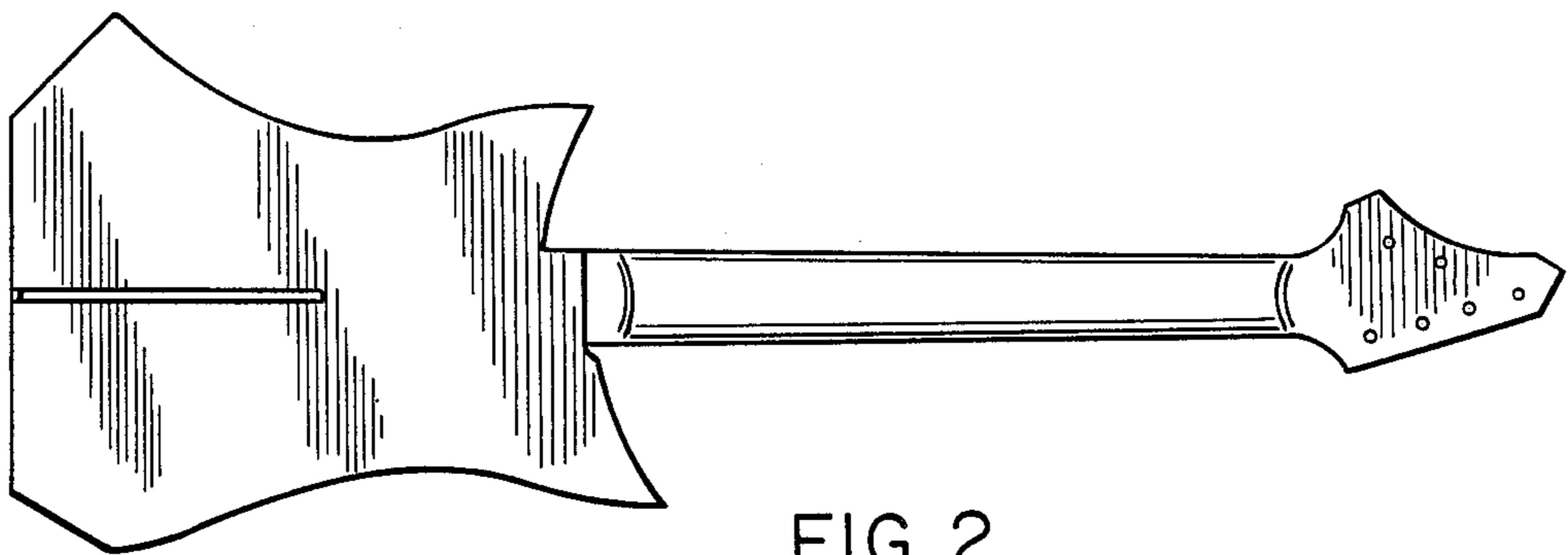

FIG. 2

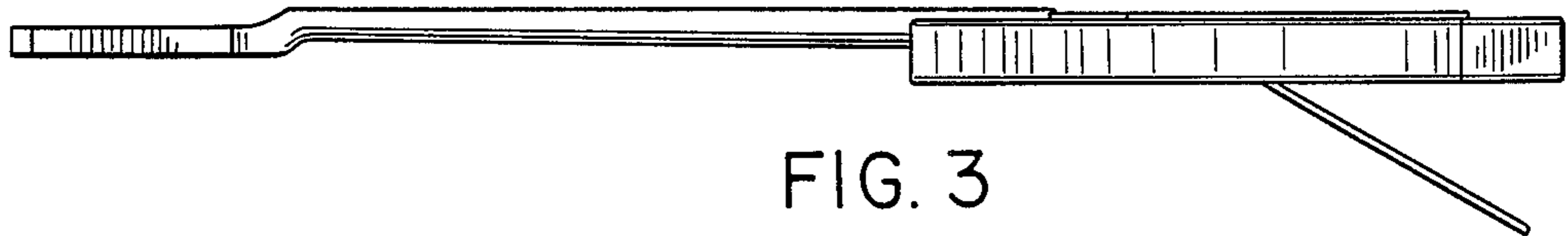

FIG. 3



FIG. 4



FIG. 5