

[54] MOPED

Attorney, Agent, or Firm—Bruce L. Adams; Van C. Wilks

[75] Inventor: Bernard Lacroix, Montbeliard, France

[57] CLAIM

[73] Assignee: Cycles Peugeot, Beaulieu, France

The ornamental design for a moped, as shown and described.

[\*\*] Term: 14 Years

DESCRIPTION

[21] Appl. No.: 822,034

FIG. 1 is a left side elevational view of a moped showing a first embodiment of my new design; FIG. 2 is a right side elevational view thereof; FIG. 3 is a top plan view thereof; FIG. 4 is a bottom plan view thereof; FIG. 5 is a front elevational view thereof; FIG. 6 is a rear elevational view thereof; FIG. 7 is a left side elevational view of a moped showing a second embodiment of my new design, it being understood that the differences reside in the telescopic front fork and the omission of the engine covers on each side thereof; FIG. 8 is a right side elevational view of the second embodiment; and FIG. 9 is a left side elevational view of a moped showing a third embodiment of my new design, it being understood that the differences reside in the telescopic front fork, the rear shock absorbers and the omission of the engine covers on each side thereof.

[22] Filed: Jan. 24, 1986

[30] Foreign Application Priority Data

Jul. 25, 1985 [FR] France ..... 853626  
[52] U.S. Cl. .... D12/110  
[58] Field of Search ..... D12/110, 111;  
280/281 R; 180/219, 225, 229

[56] References Cited

U.S. PATENT DOCUMENTS

D. 209,122 10/1967 Elia ..... D12/110  
D. 241,527 9/1976 Kojo ..... D12/110  
D. 263,038 2/1982 Kobayashi ..... D12/110

Primary Examiner—James M. Gandy

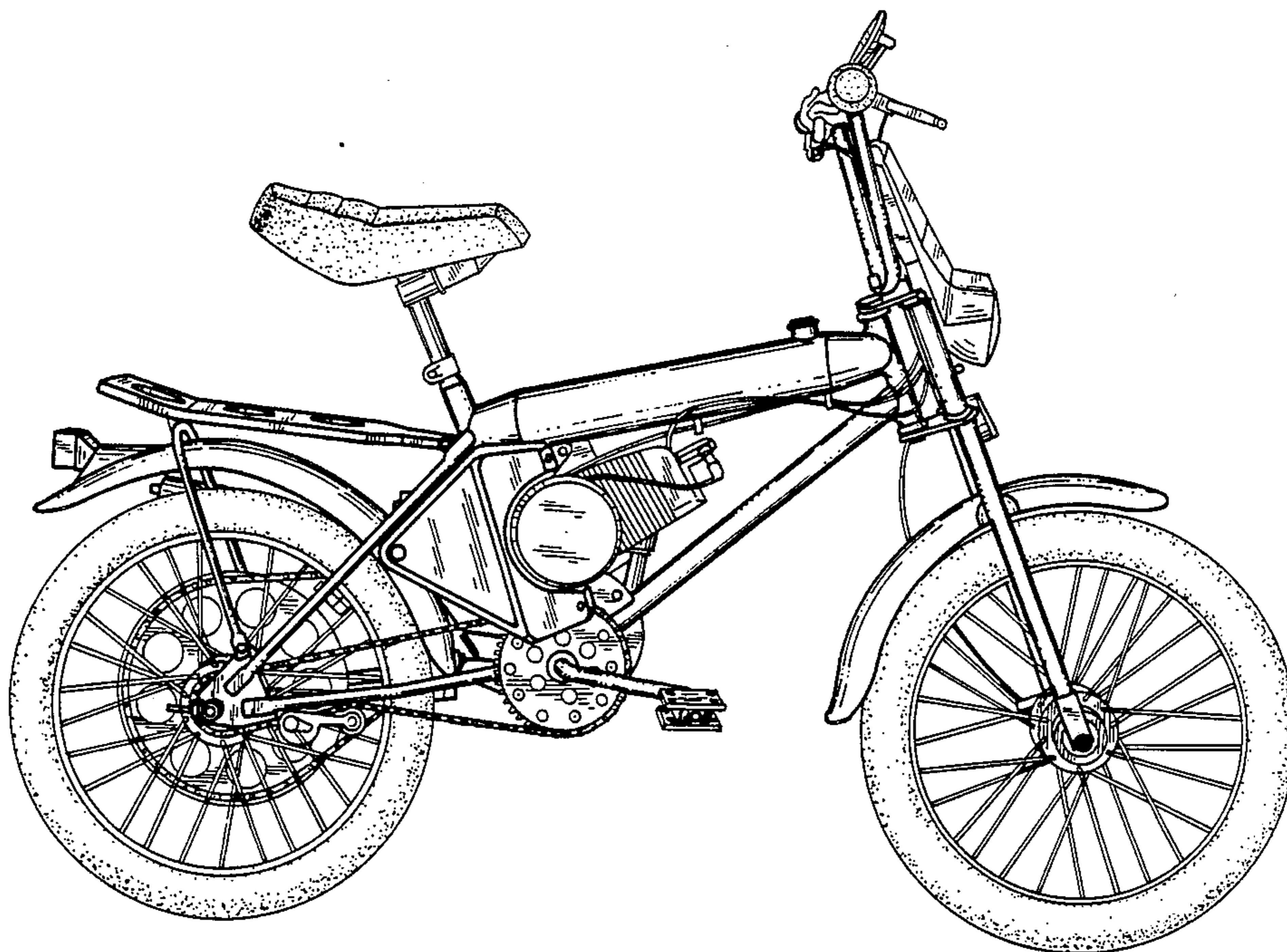

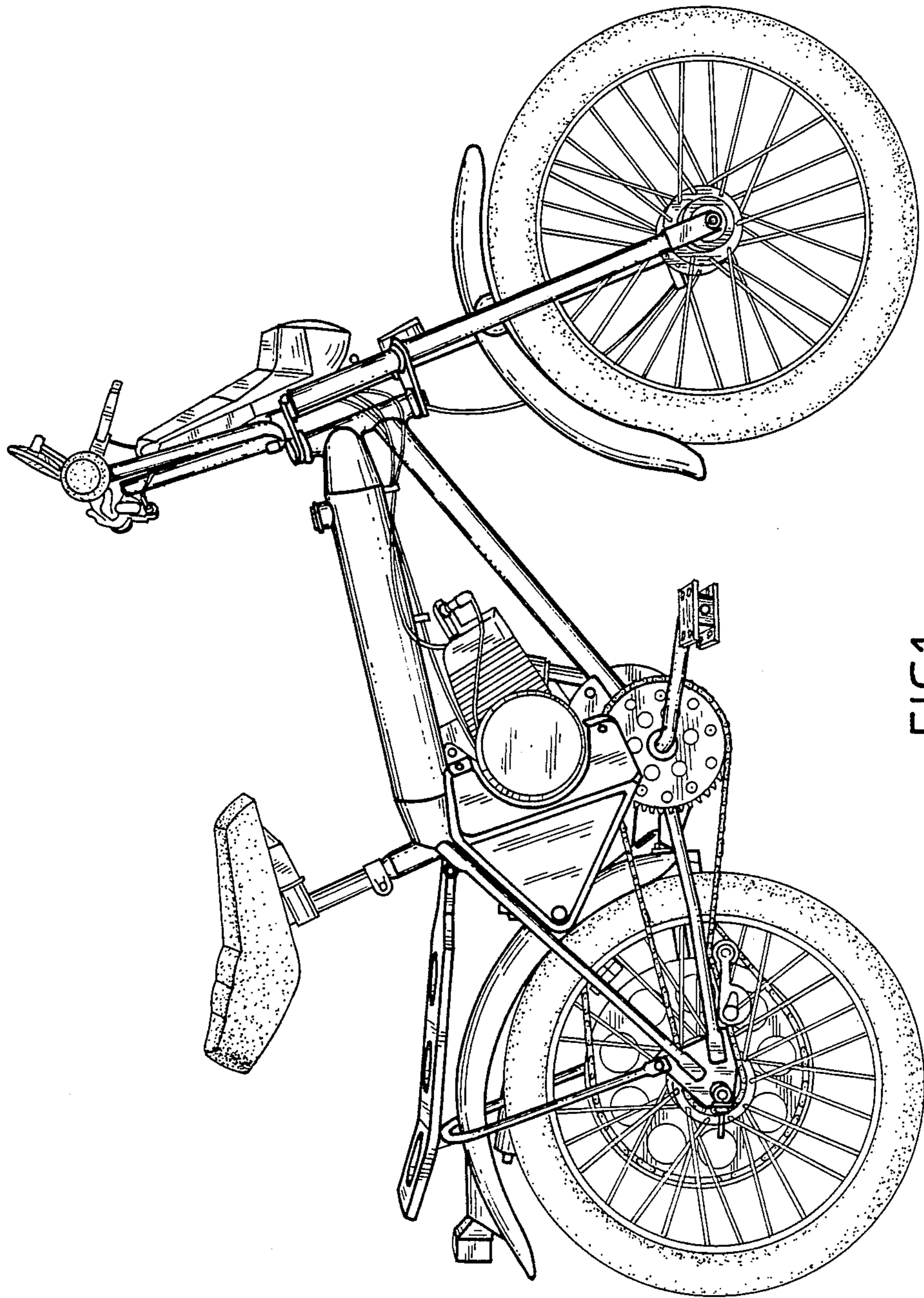

FIG. 1



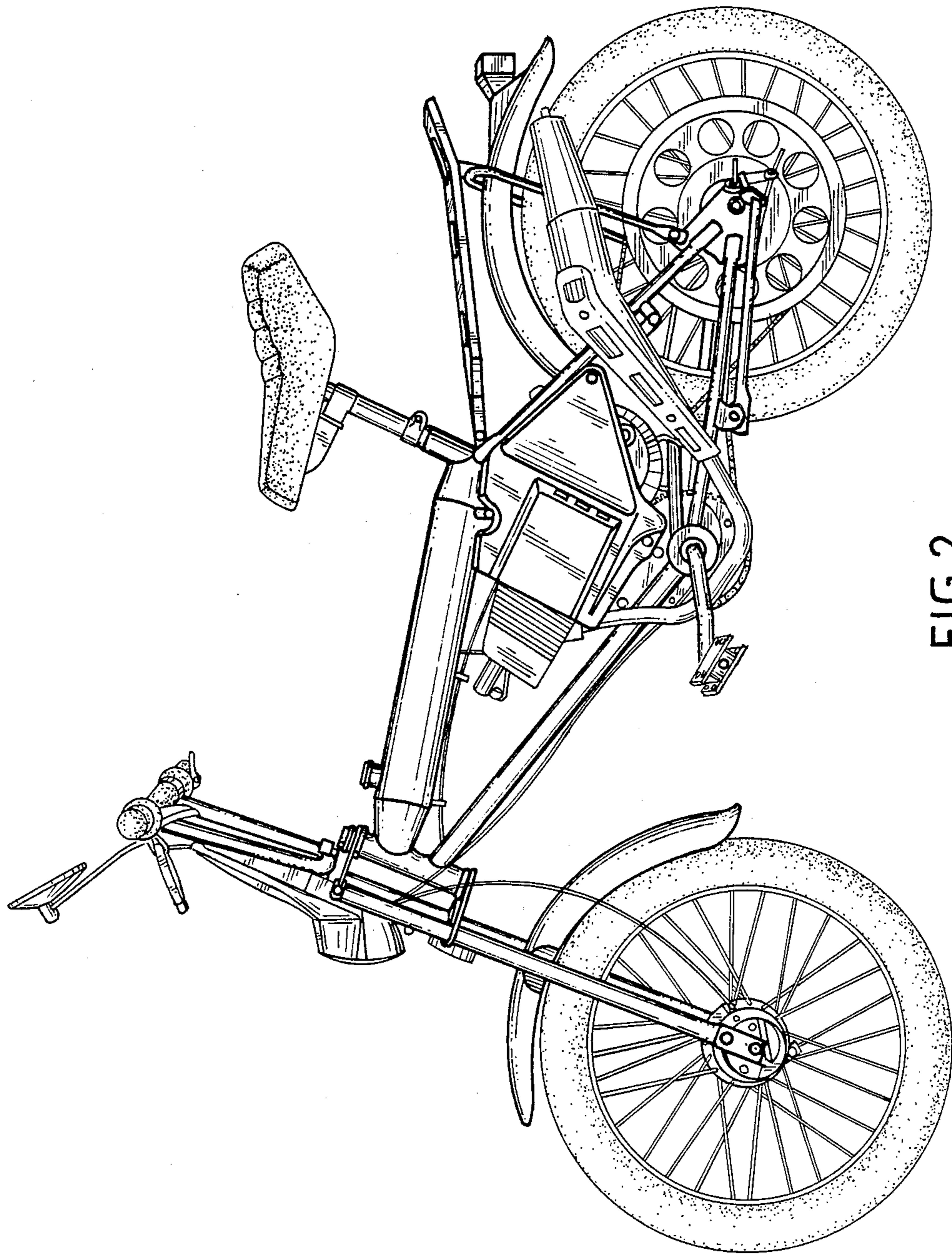

FIG. 2

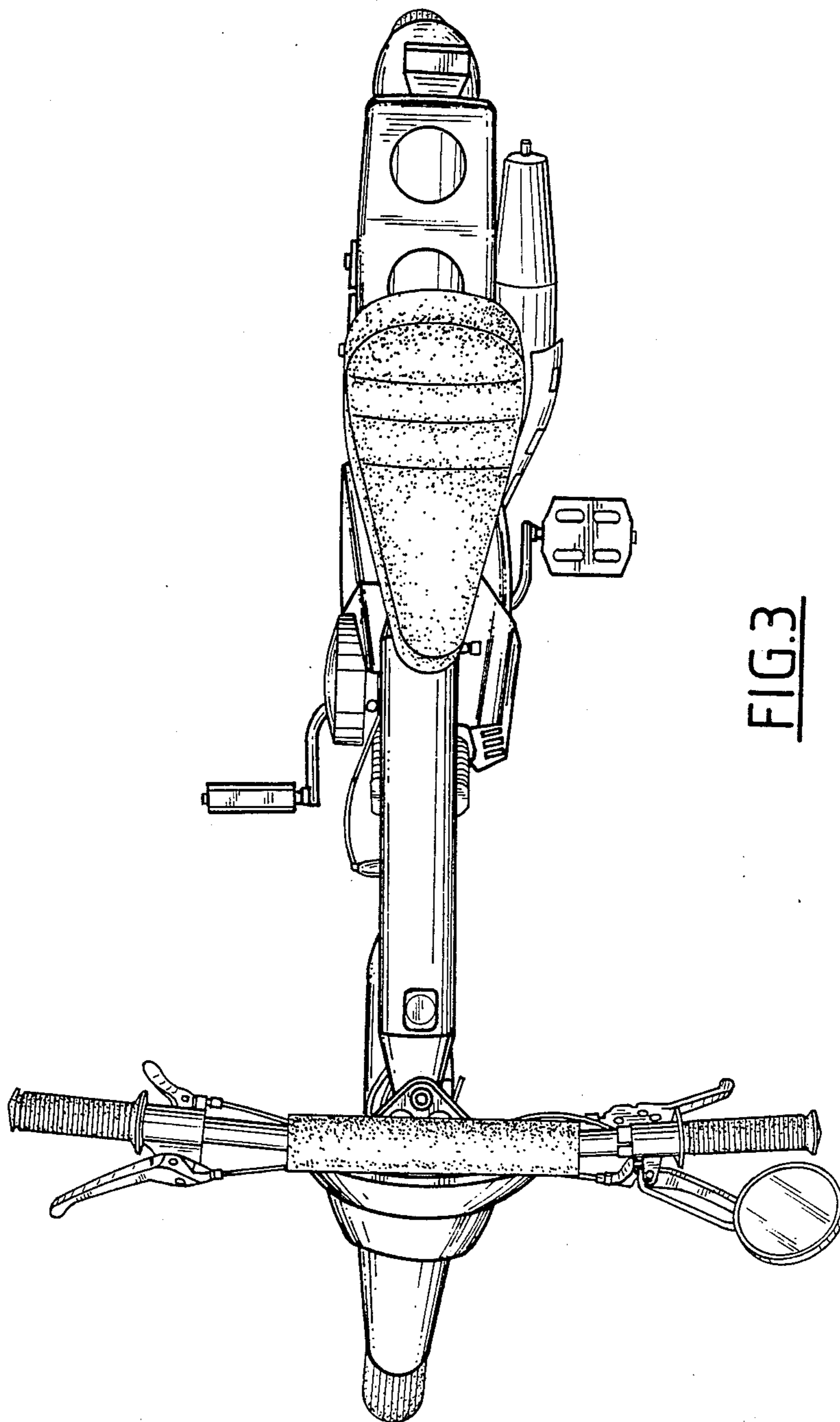

FIG. 3

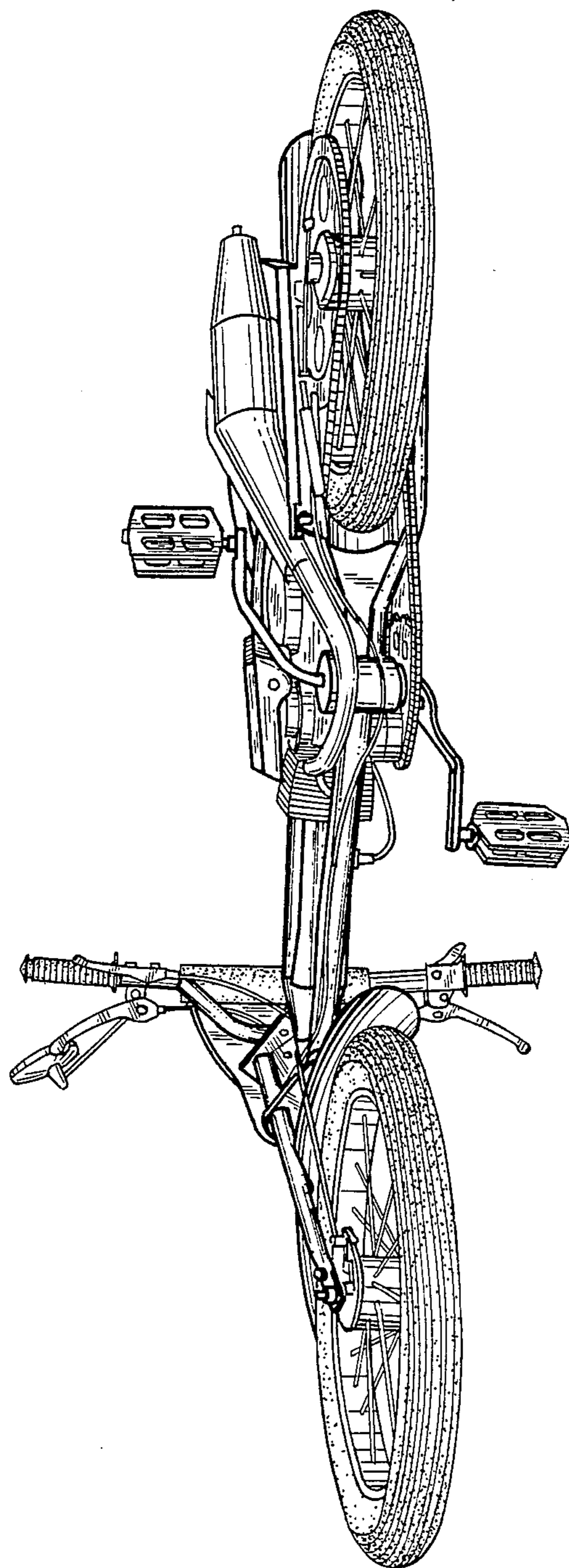

FIG. 4

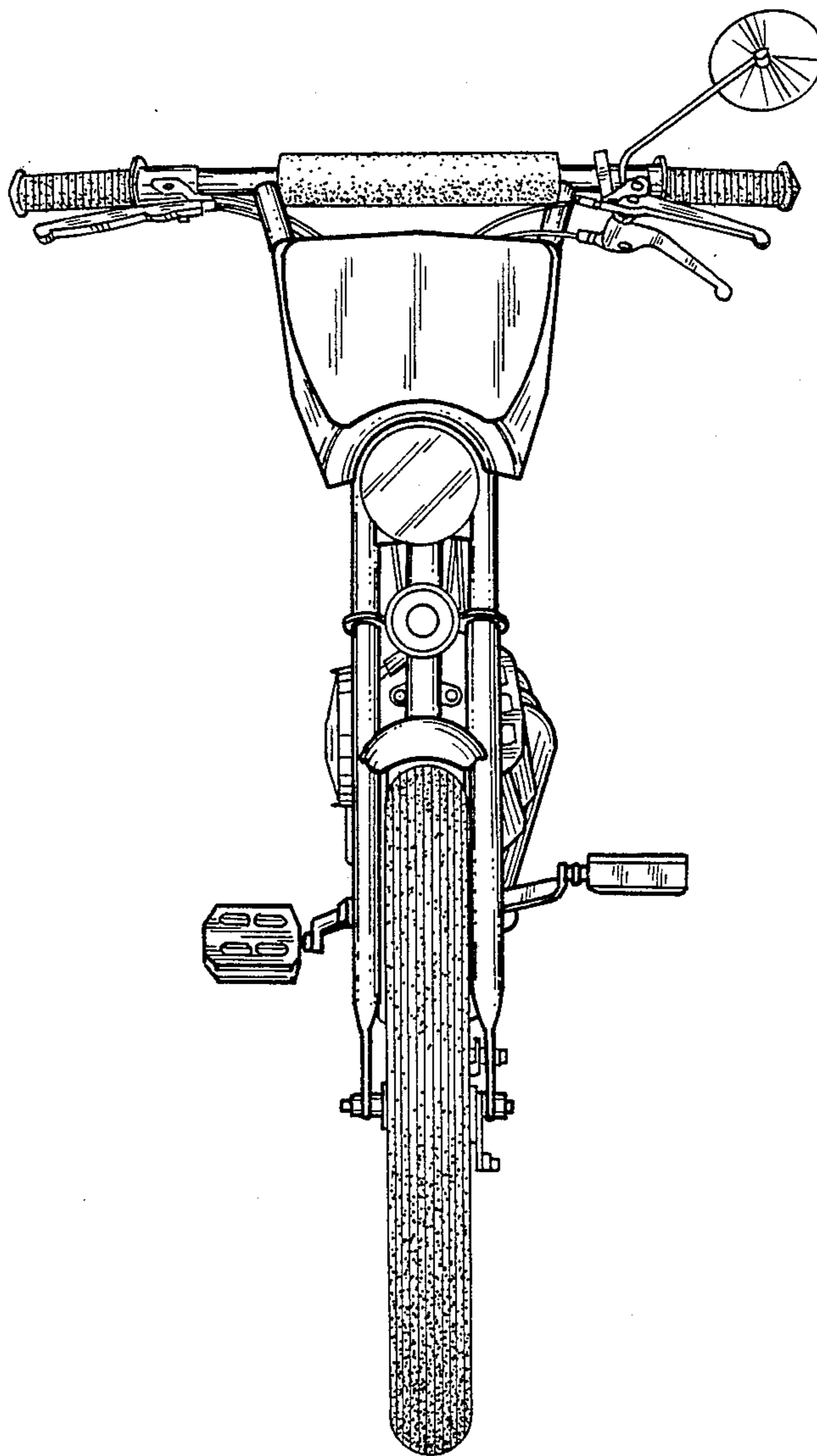

FIG. 5



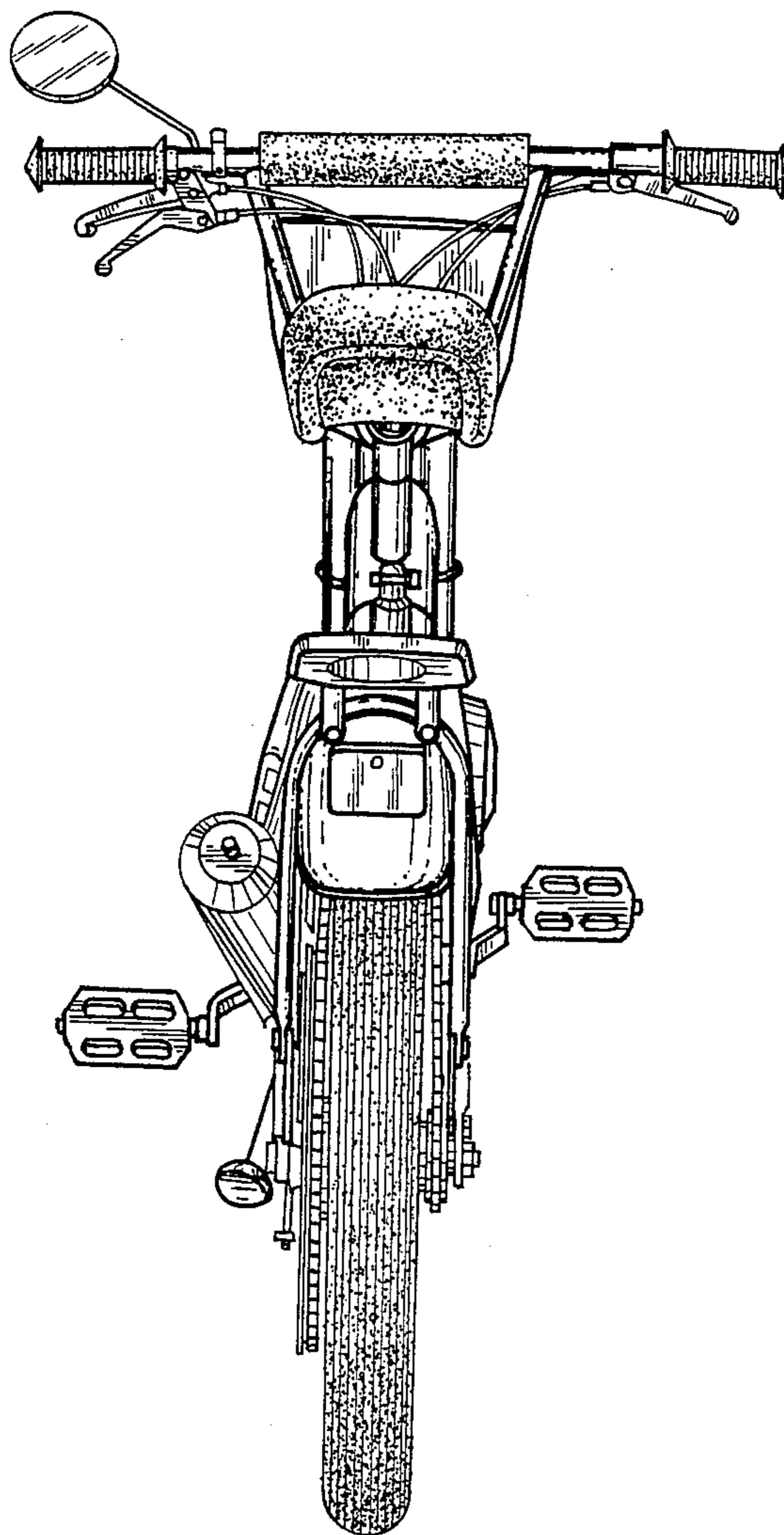

FIG. 6

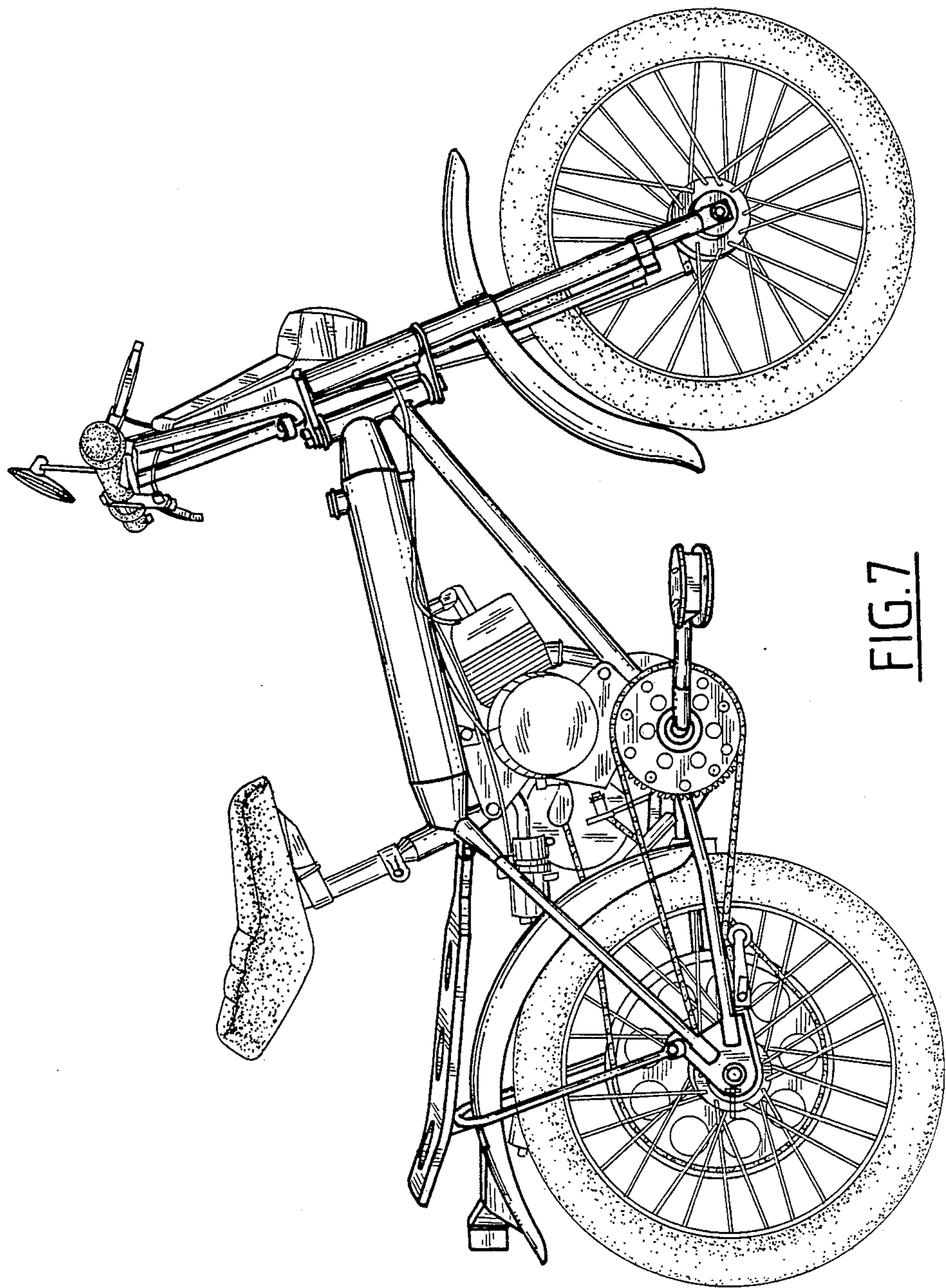

FIG. 7



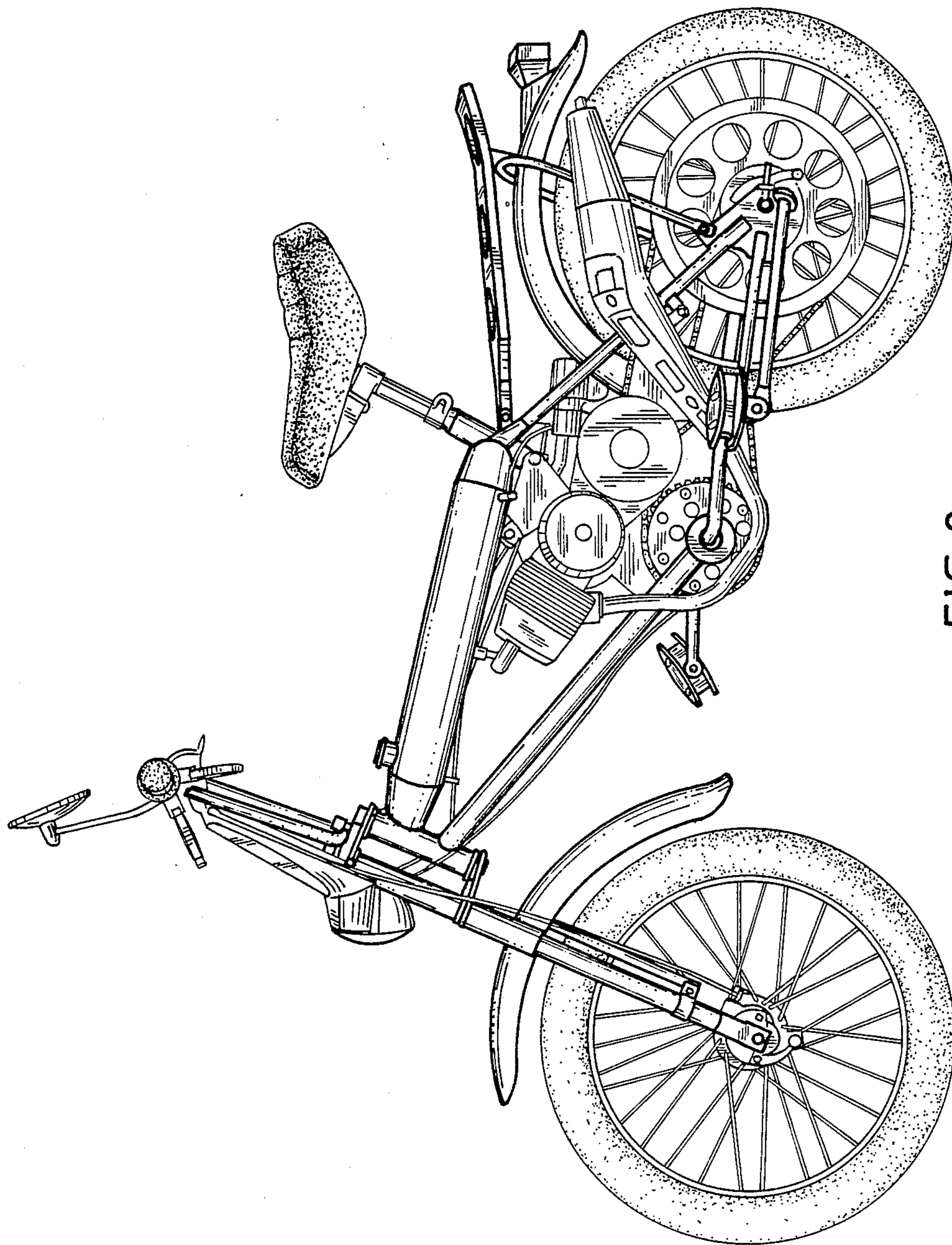

FIG. 8

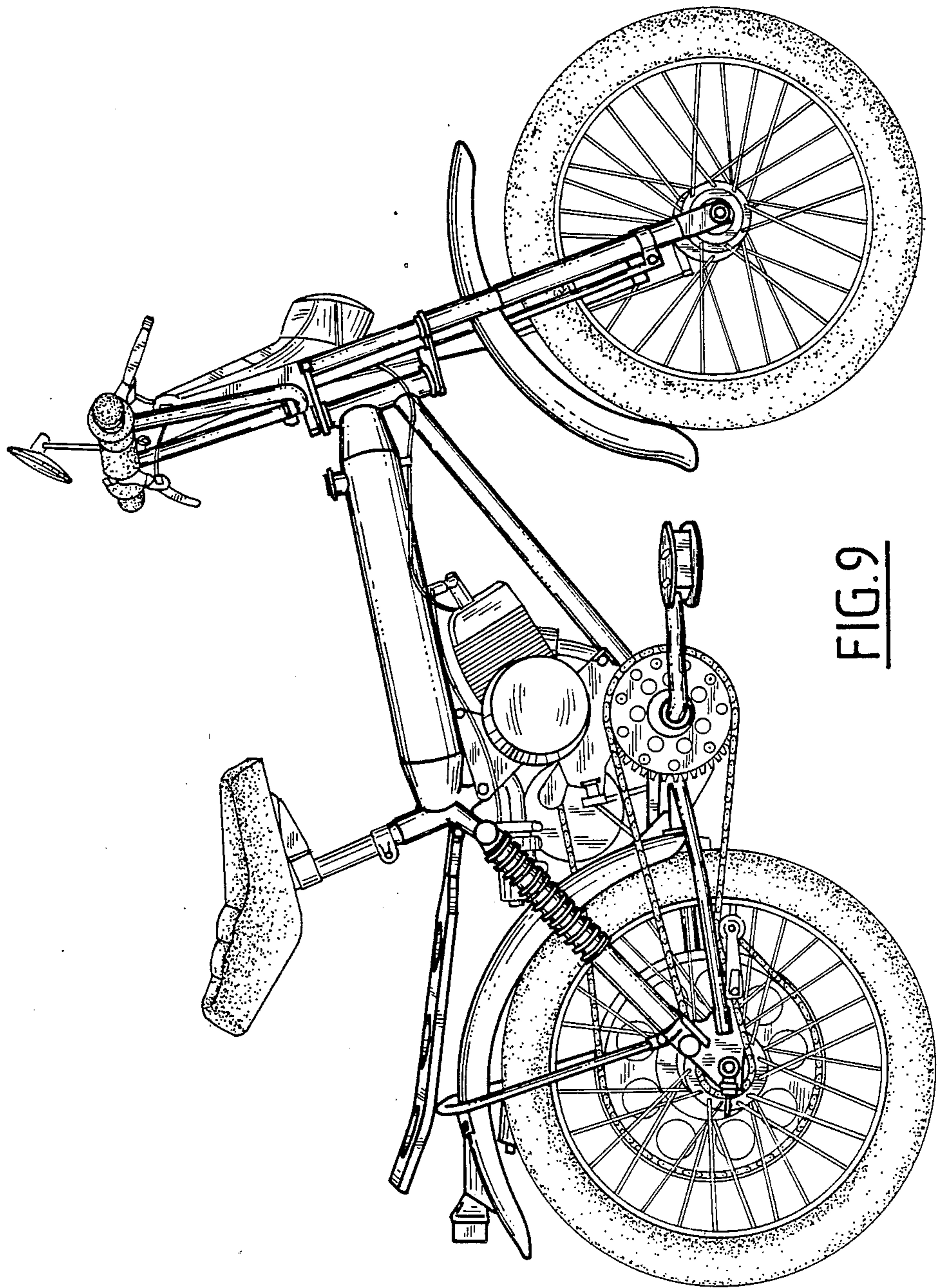

FIG. 9