

[54] VEHICLE TIRE

[75] Inventor: Glynne D. Miller, Pickerington, Ohio

[73] Assignee: Kenda Rubber Industrial Co., Ltd., Yuanlin, Taiwan

[**] Term: 14 Years

[21] Appl. No.: 871,585

[22] Filed: Jun. 6, 1986

[52] U.S. Cl. D12/149

[58] Field of Search D12/136, 146-151; 152/209 R, 209 D, 209 B

[56] References Cited

PUBLICATIONS

J. C. Whitney Catalog No. 454D, ©1985, p. 194, Wedged Chevron Tread Tire B, center of page. 1985 Tread Design Guide, p. 214, Co-Op Implement Agri Traction Drive Tire, second tire in from bottom right side of page.

Primary Examiner—James M. Gandy

Attorney, Agent, or Firm—Robert E. Stebens

[57] CLAIM

The ornamental design for a vehicle tire, as shown and described.

DESCRIPTION

FIG. 1 is a perspective view of a vehicle tire showing my new design, it being understood that the tread pattern and sidewall portion continue throughout the circumference of the tire shown schematically in solid lines, the opposite side being substantially the same as that shown.

FIG. 2 is a fragmentary developed plan view of the tread pattern thereof on an enlarged scale.

FIG. 3 is a cross-sectional view of the tire as taken along line 3—3 of FIG. 2.

FIG. 4 is a cross-sectional view of the tire as taken along line 4—4 of FIG. 2.

FIG. 5 is a sectional view on an enlarged scale taken along line 5—5 of FIG. 2 and is typical of each of the other tread elements at their major transverse dimension.

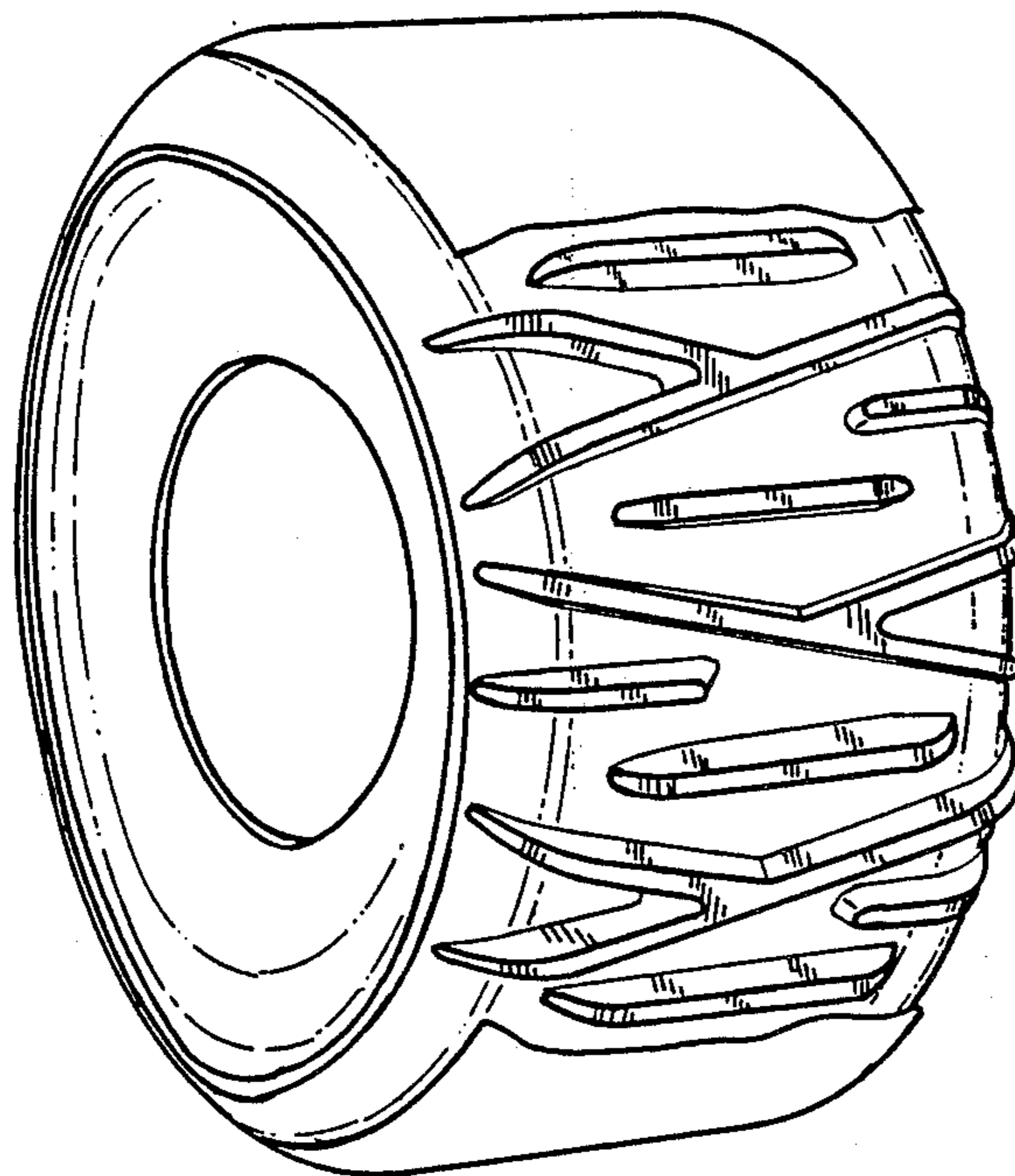

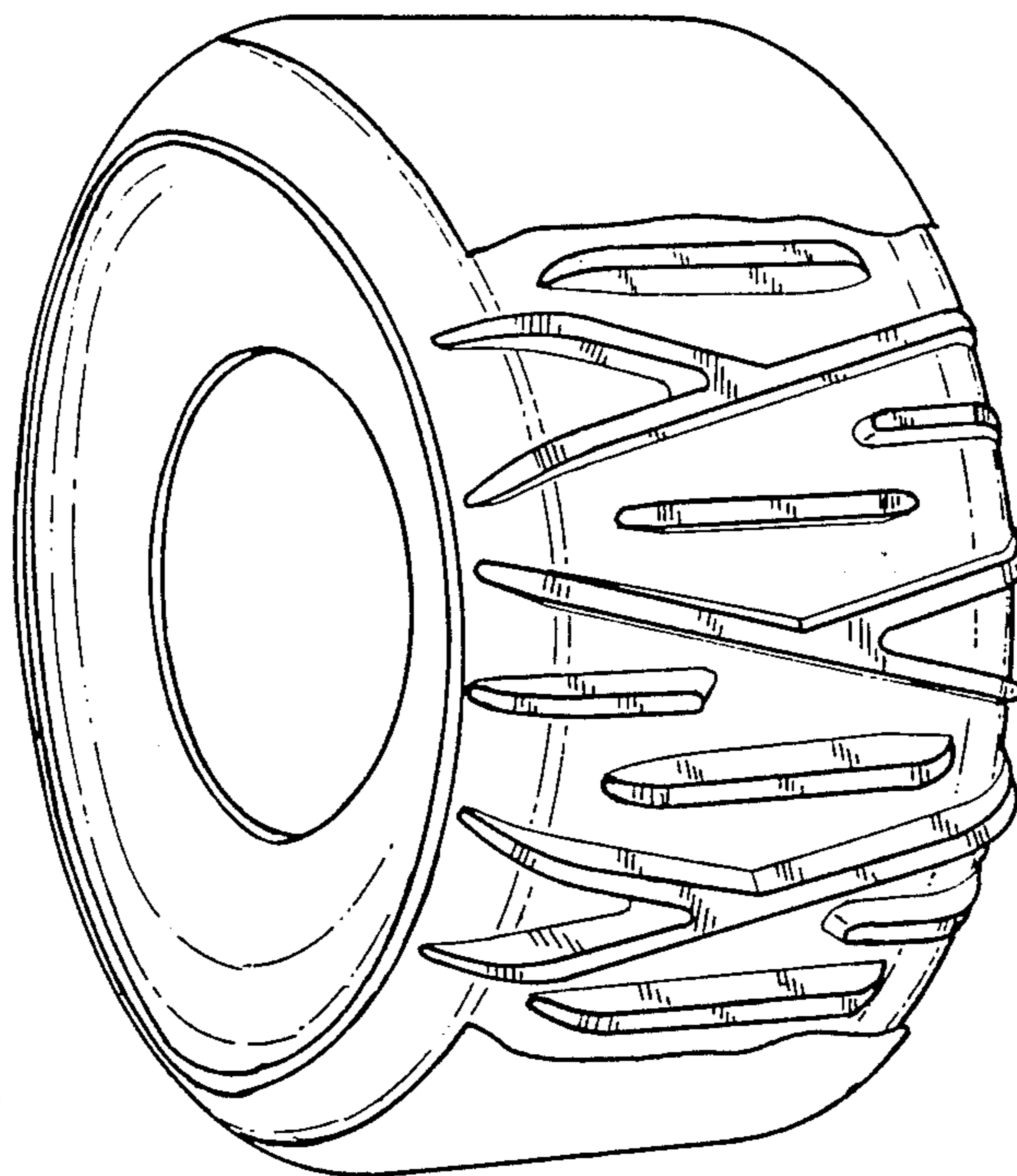

FIG. 1

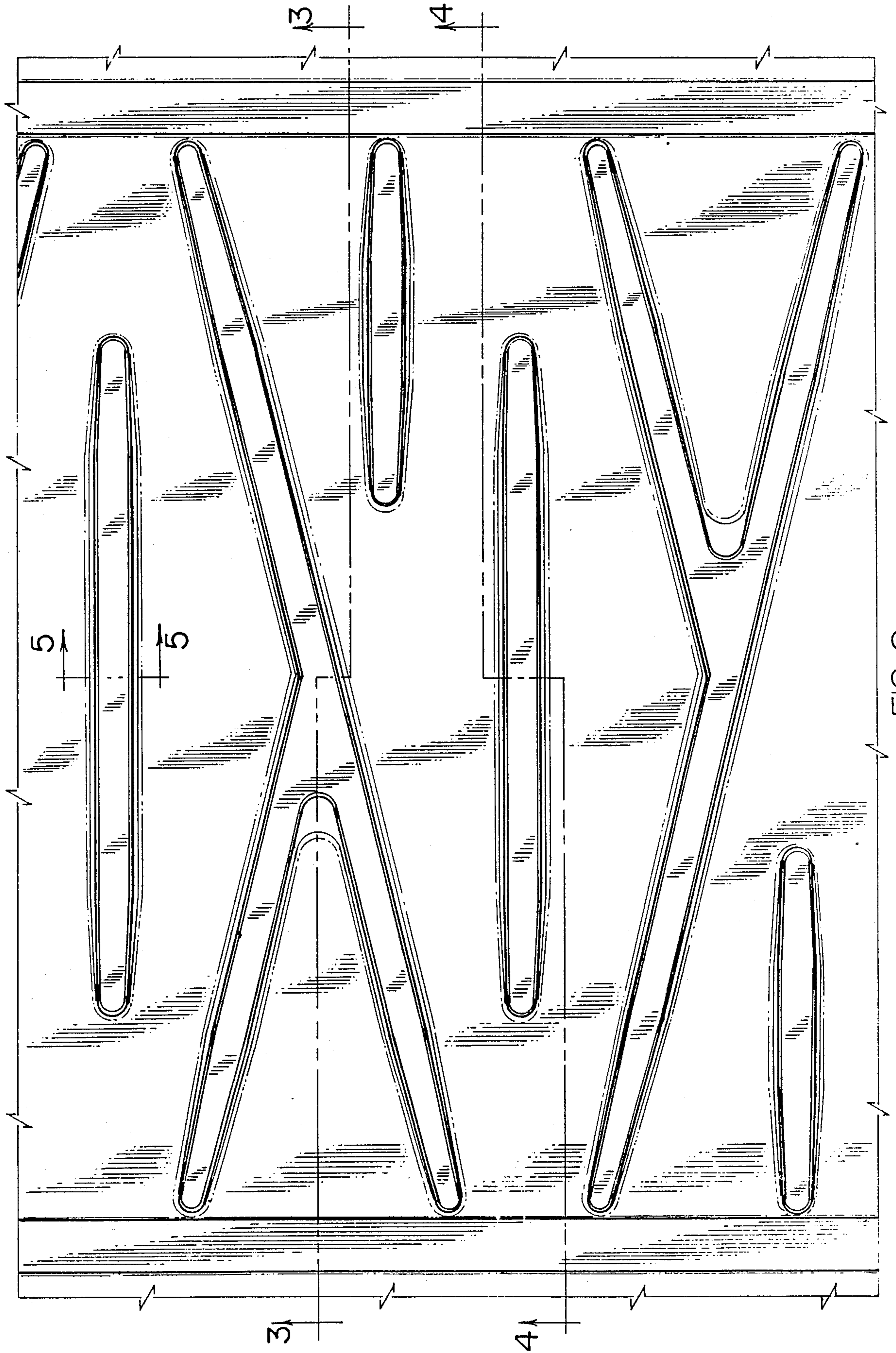

FIG. 2

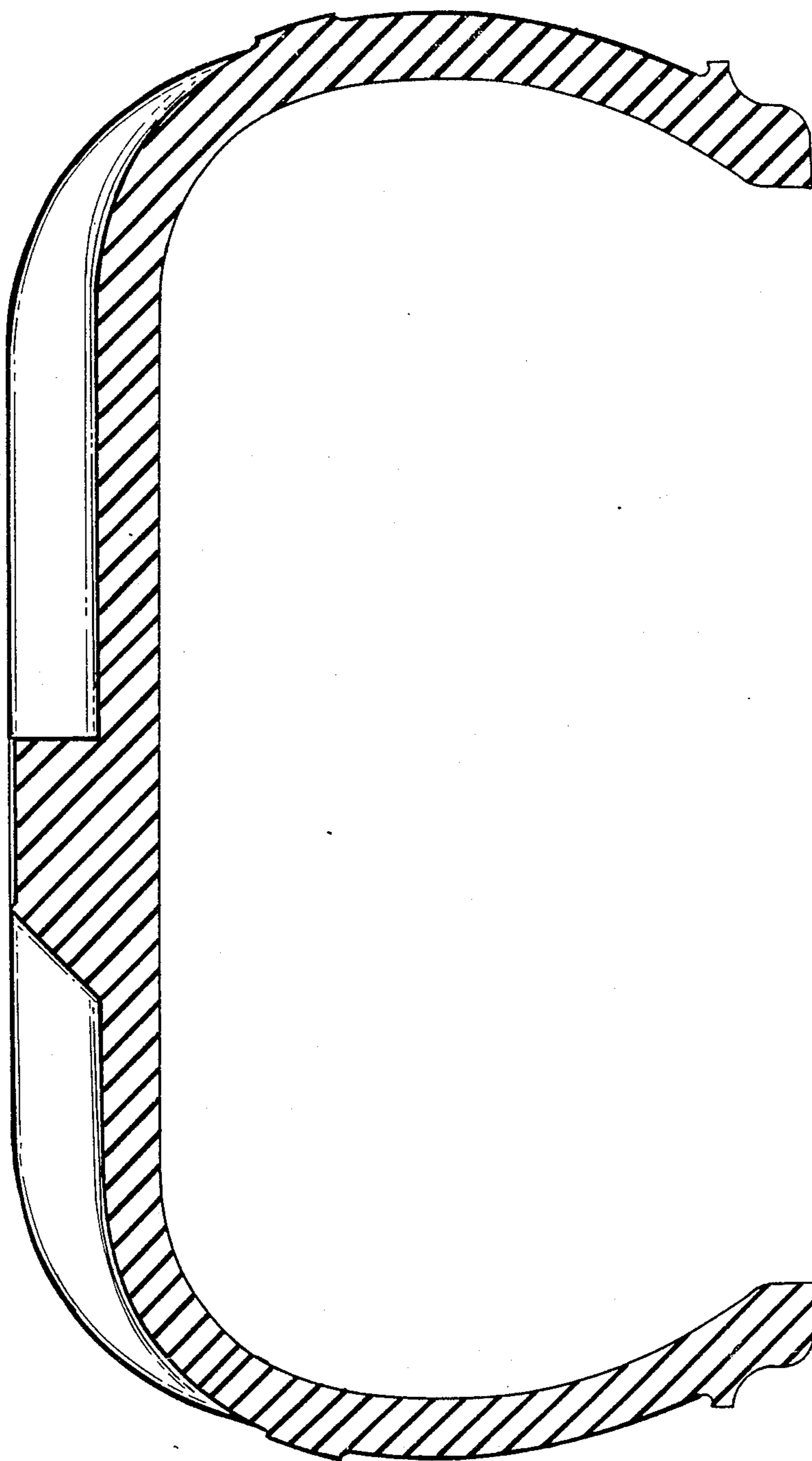

FIG. 3

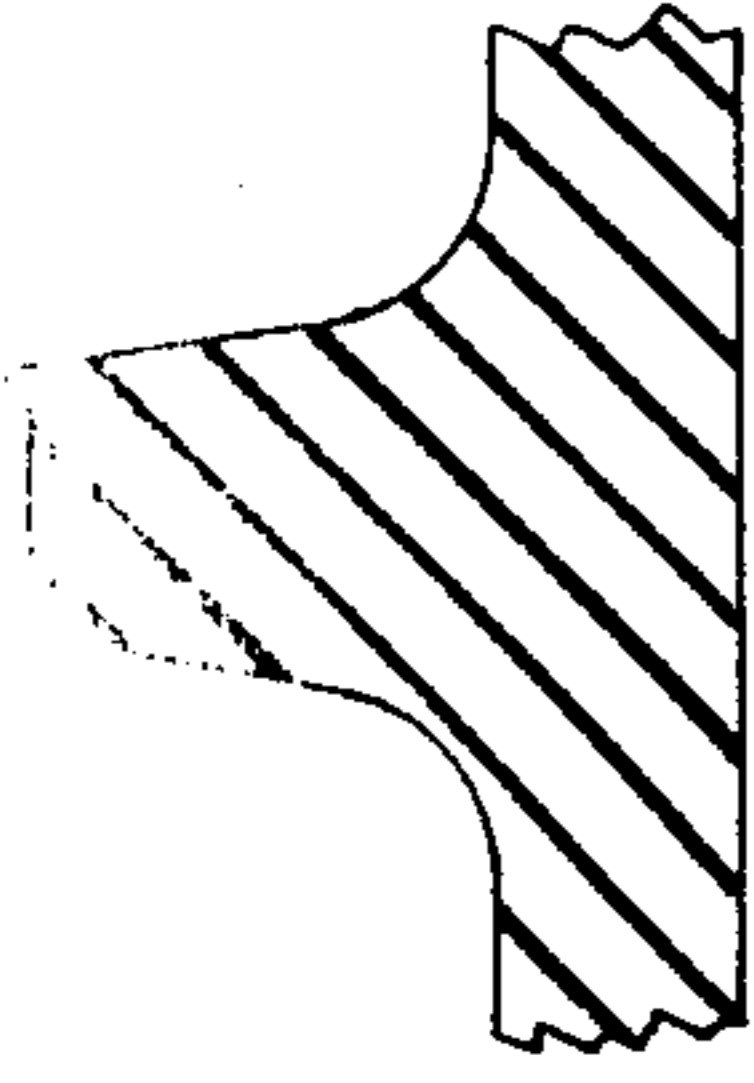

FIG. 5

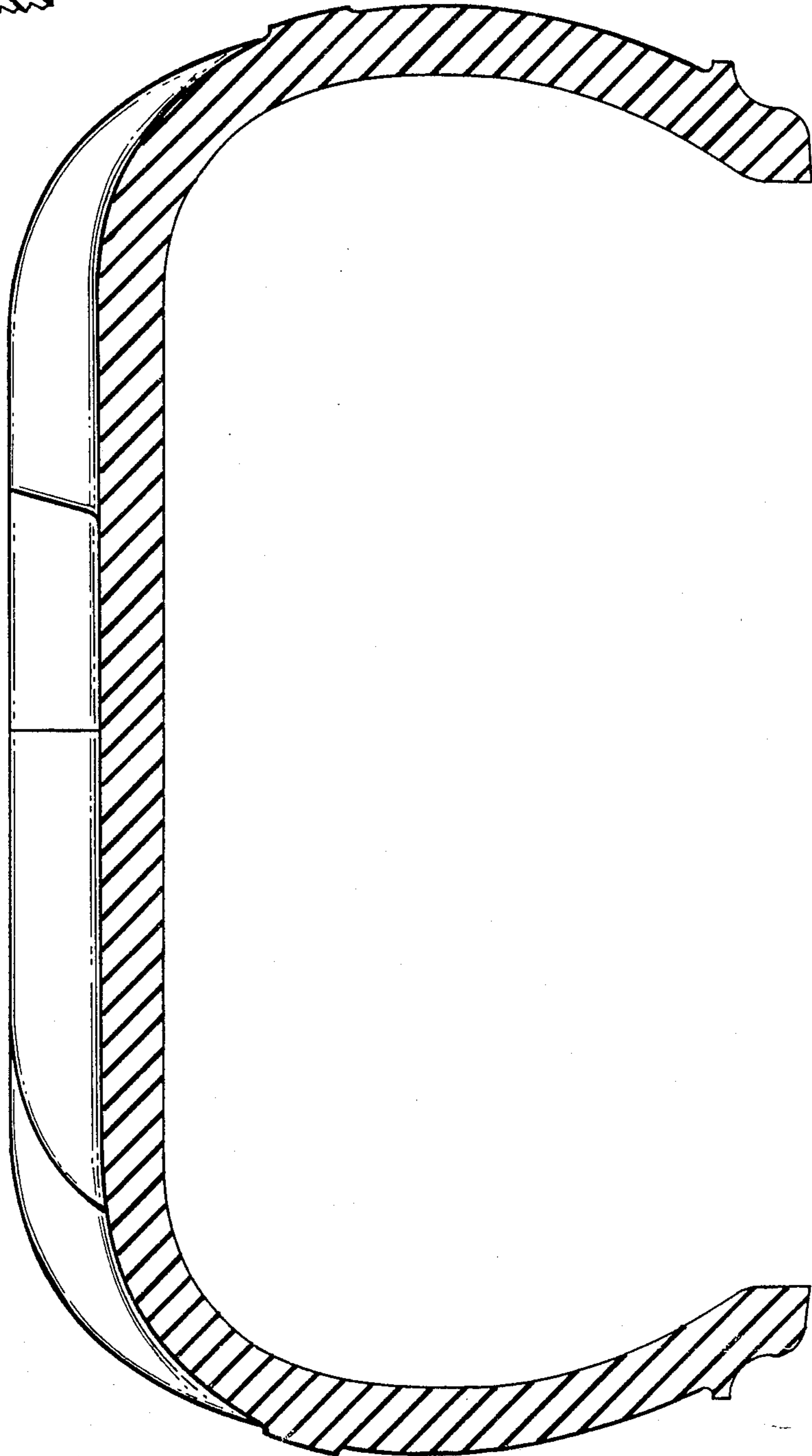

FIG. 4