

[54] **PAINTER'S SERVICE CART**
 [76] **Inventor: John C. Gottselig, 405 S. Jackson St., Wilmington, Del. 19805**
 [**] **Term: 14 Years**
 [21] **Appl. No.: 933,677**
 [22] **Filed: Nov. 20, 1986**
 [52] **U.S. Cl. D34/23; D34/28; D34/17**
 [58] **Field of Search D34/17, 12, 24, 28, D34/31; 280/35, 79.1 A, 79-34; 108/145; 248/421; D32/55, 58, 53**

4,249,749 2/1981 Collier 280/79.1 A
FOREIGN PATENT DOCUMENTS
 2446210 9/1980 France 280/47.34

Primary Examiner—Wallace R. Burke
Assistant Examiner—Kay H. Chin
Attorney, Agent, or Firm—Dann, Dorfman, Herrell & Skillman

[57] **CLAIM**

The ornamental design for a painter's service cart, as shown and described.

DESCRIPTION

FIG. 1 is a perspective view of a painter's service cart showing my new design, with the cart fully extended and the cover element in a vertical position;
 FIG. 2 is a front elevational view thereof, with the cart partially retracted and the cover element in a horizontal position;
 FIG. 3 is a front elevational view thereof, with the cart fully retracted and the cover element in a vertical position;
 FIG. 4 is a right side elevational view of FIG. 3;
 FIG. 5 is a left side elevational view of FIG. 3;
 FIG. 6 is a top plan view of FIG. 3;
 FIG. 7 is a bottom plan view of FIG. 3; and
 FIG. 8 is an enlarged sectional view taken on the line 8—8 in FIG. 4.
 The rear elevation of the painter's service cart is the mirror image of the front elevation.

[56] **References Cited**
U.S. PATENT DOCUMENTS
 1,754,974 4/1930 Warfield 248/421
 2,581,023 1/1952 Jerick 311/93
 2,659,917 11/1953 Drum 15/121.2
 2,805,905 9/1957 Levitan et al. 248/421
 2,905,275 9/1959 Kostolecki et al. 188/74
 2,942,290 6/1960 Segal 16/35
 2,982,982 5/1961 Swift 15/257.06
 2,993,675 7/1961 Tatter 248/421
 3,264,672 8/1966 Campbell et al. 15/257.06
 3,700,070 10/1972 King 182/16
 3,822,846 7/1974 Jesionowski 248/210
 3,861,328 1/1975 Lawless 248/421
 3,870,333 3/1975 Burdick et al. 280/47.35
 3,947,135 3/1976 Hawk 401/121
 4,010,866 3/1977 McClane 220/20
 4,167,348 9/1979 Hawk 401/121

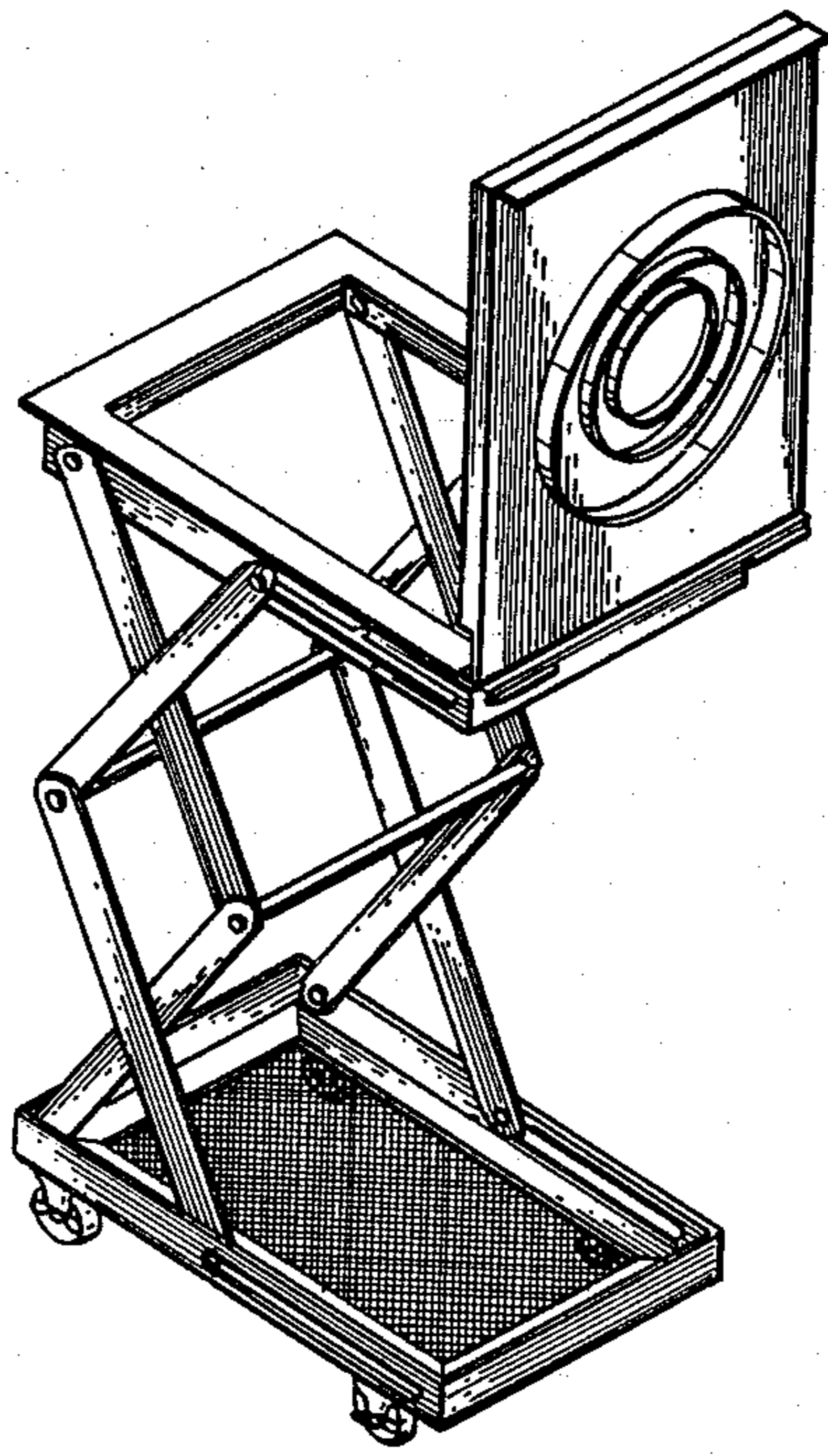

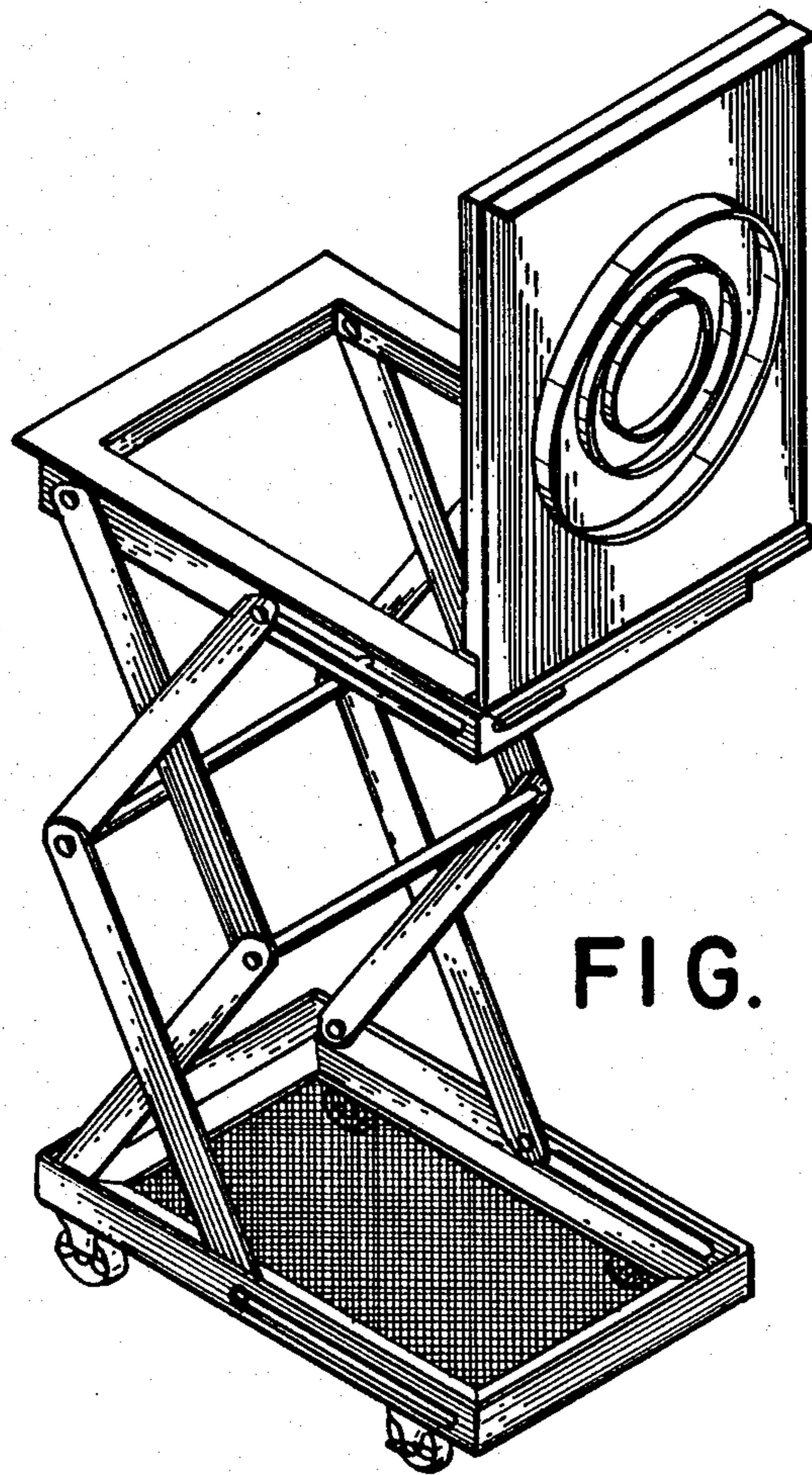

FIG. 1

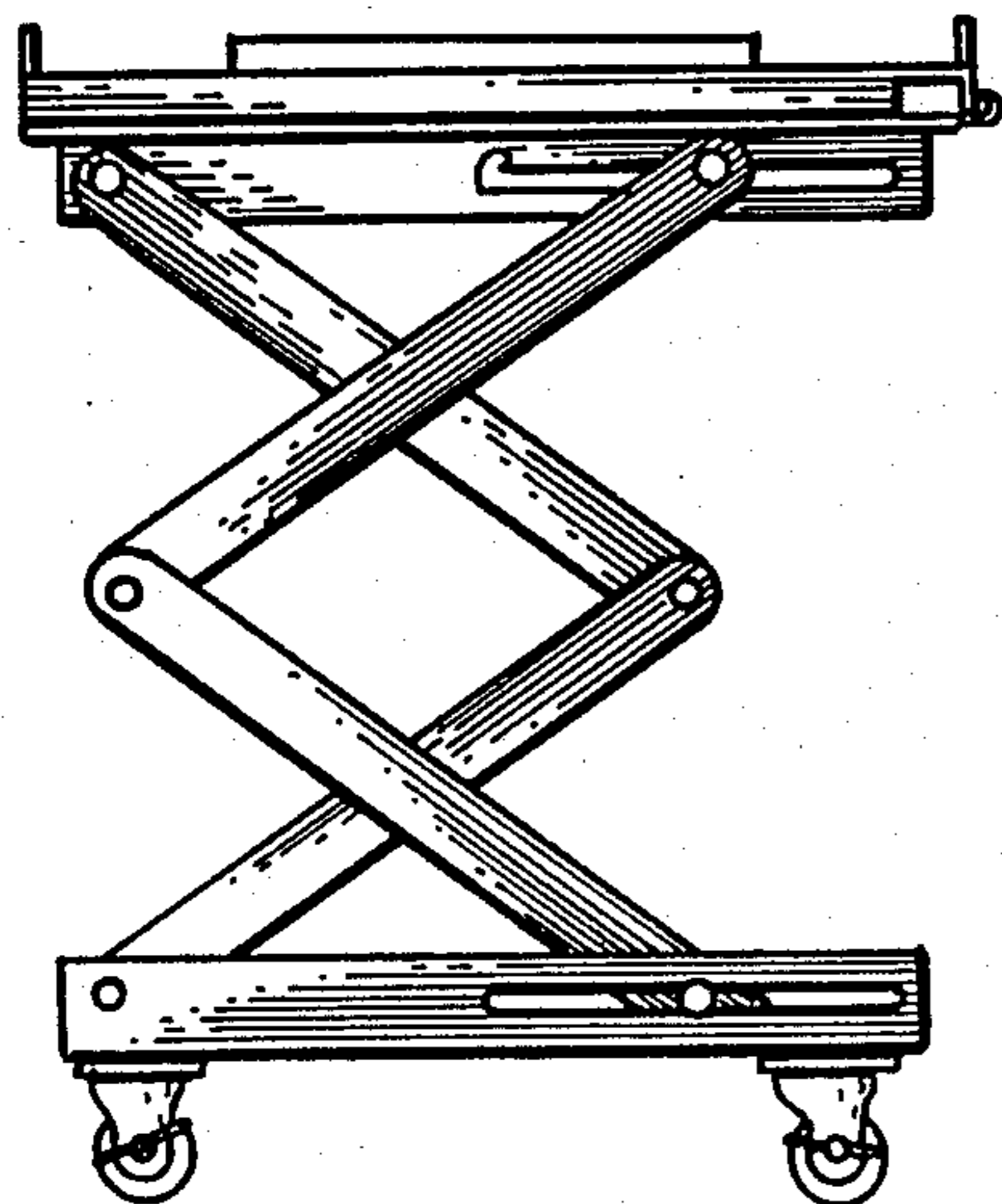

FIG. 2

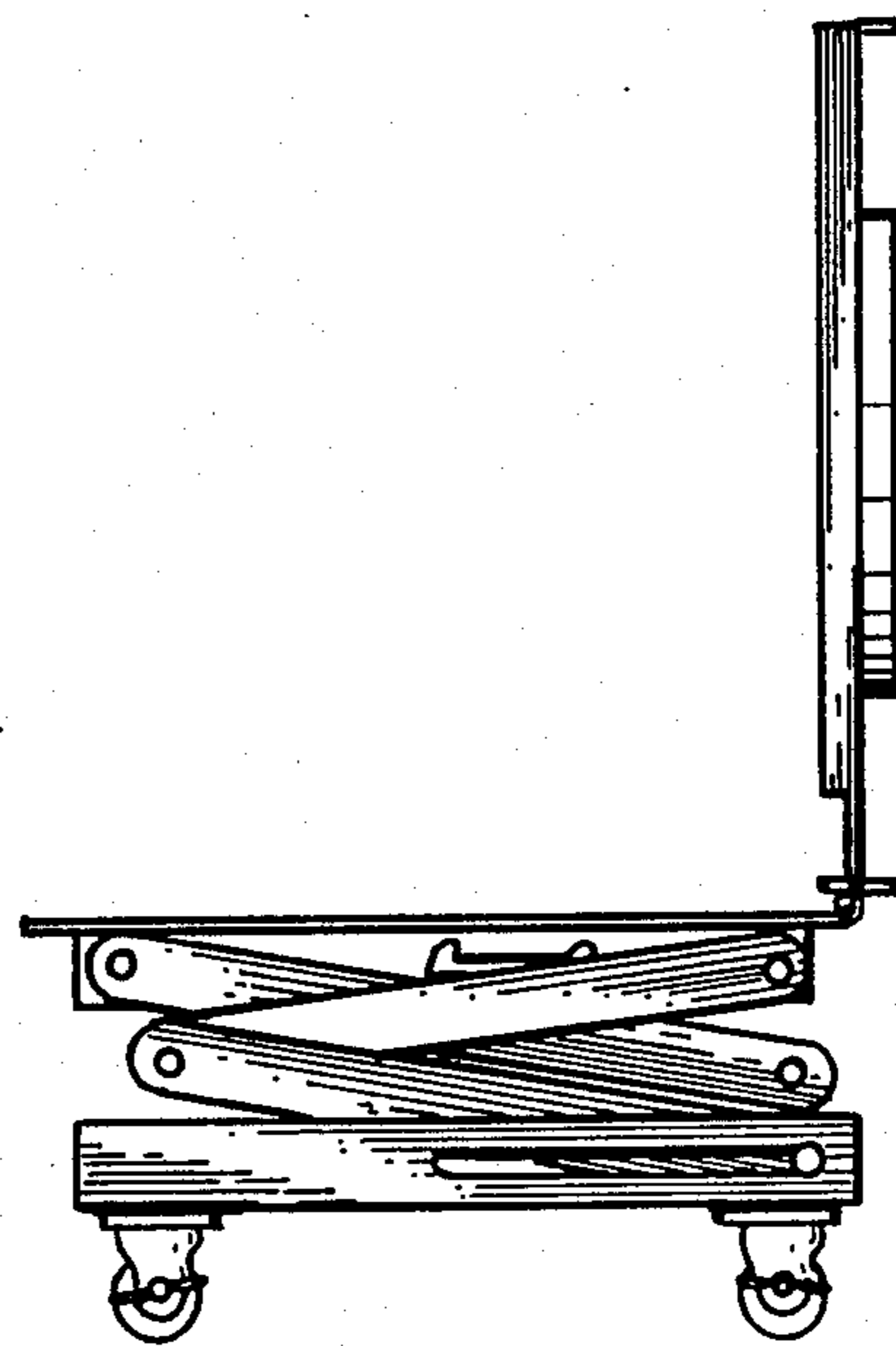

FIG. 3

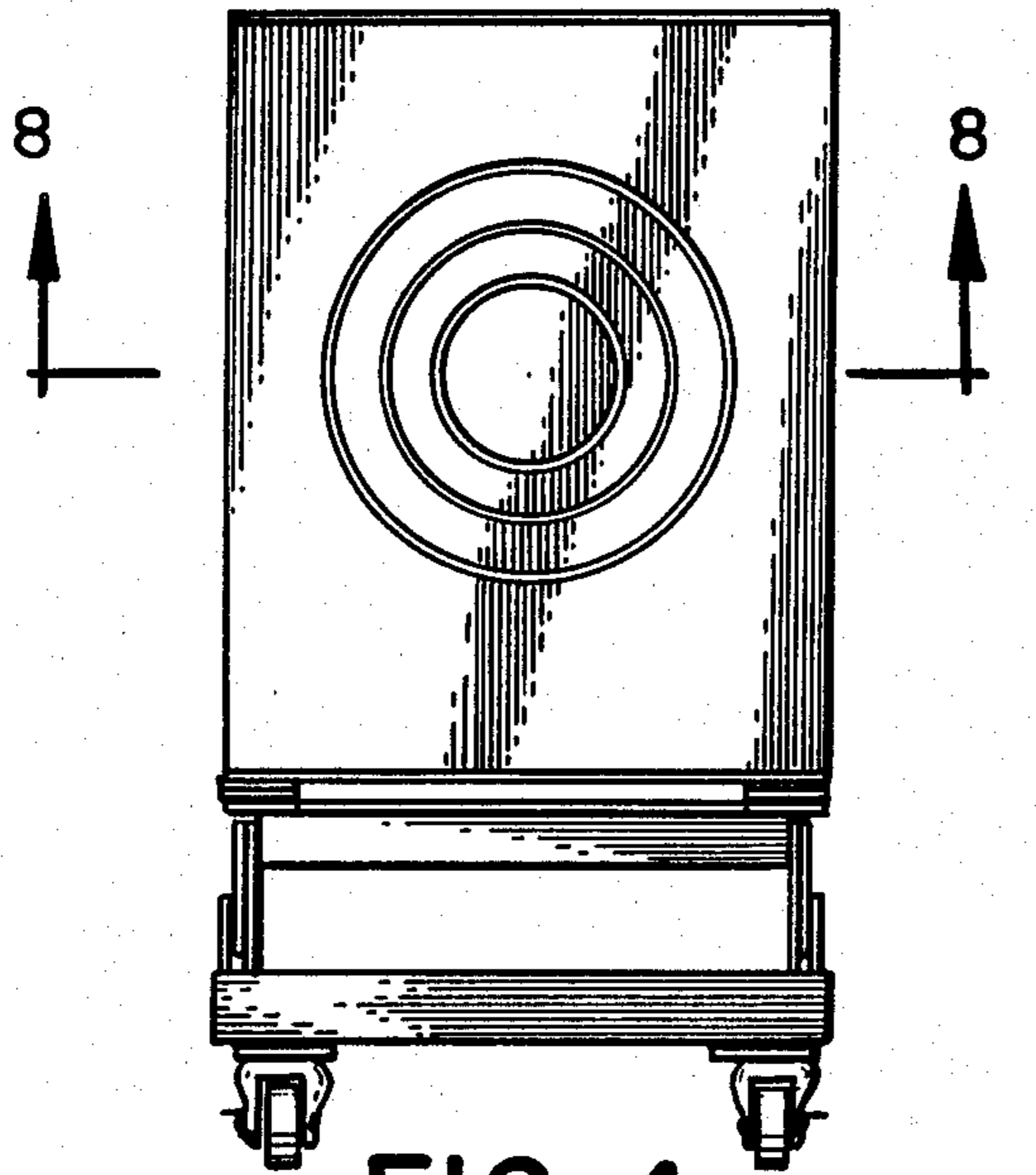

FIG. 4

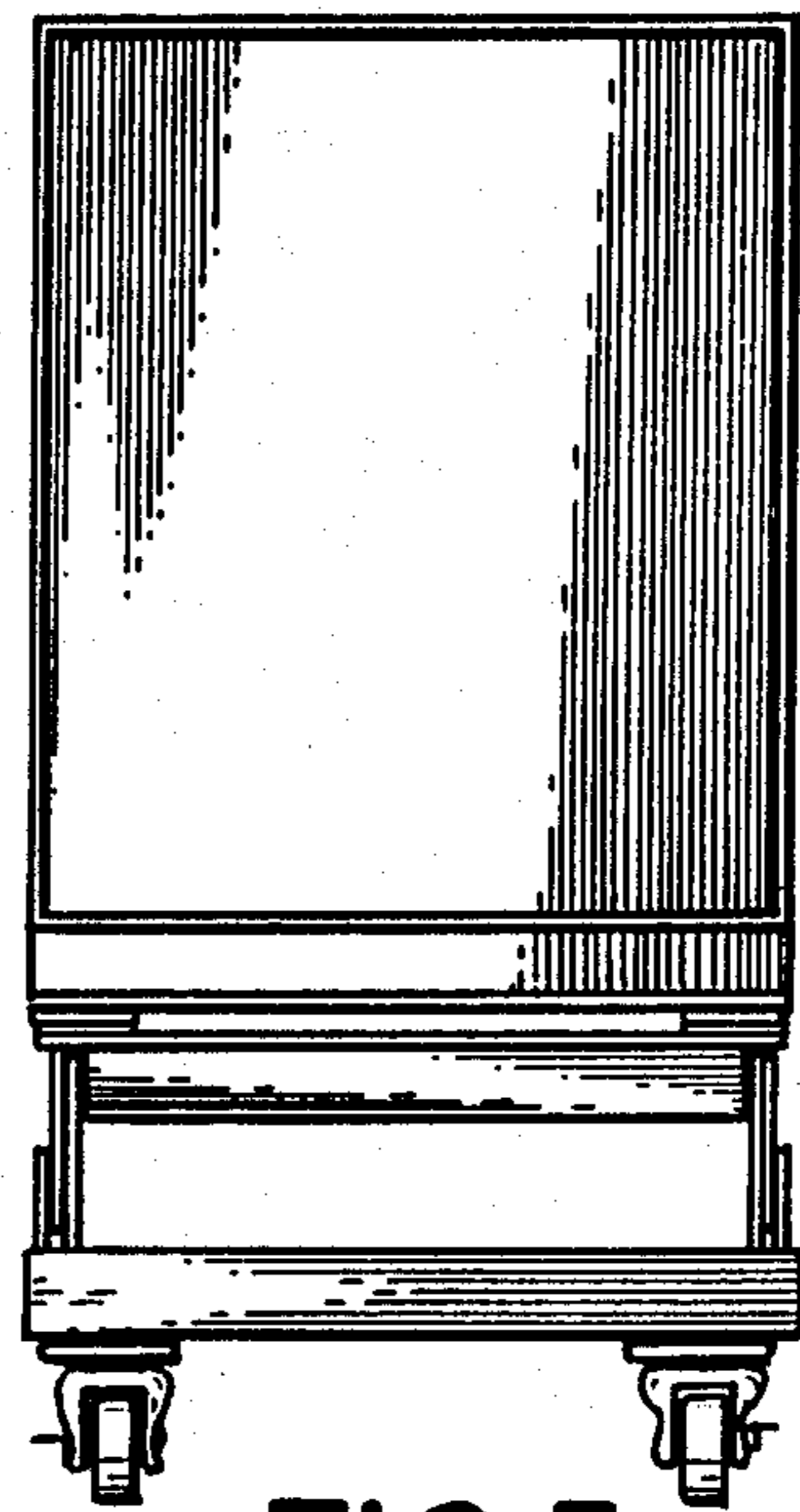

FIG. 5



FIG. 8

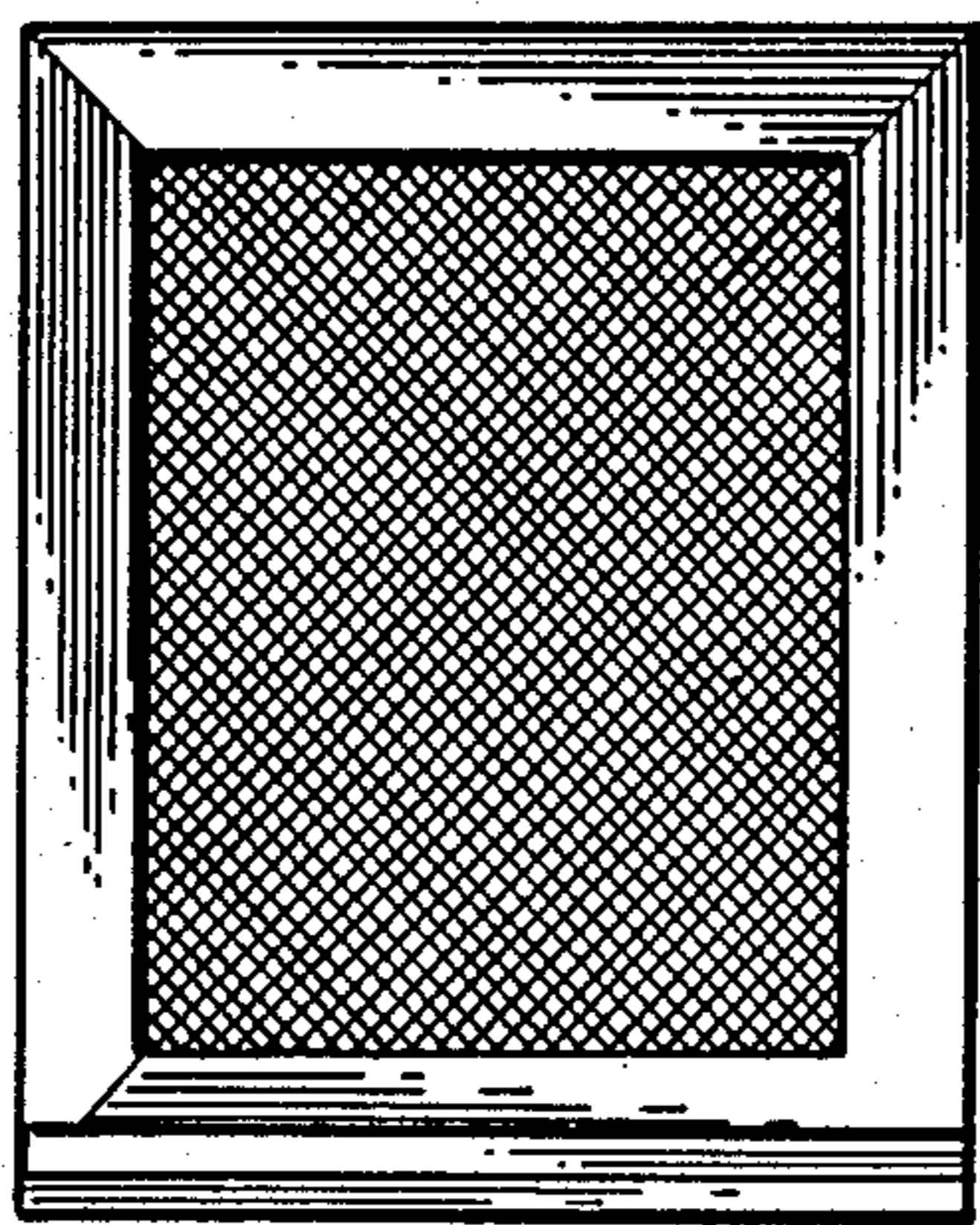

FIG. 6

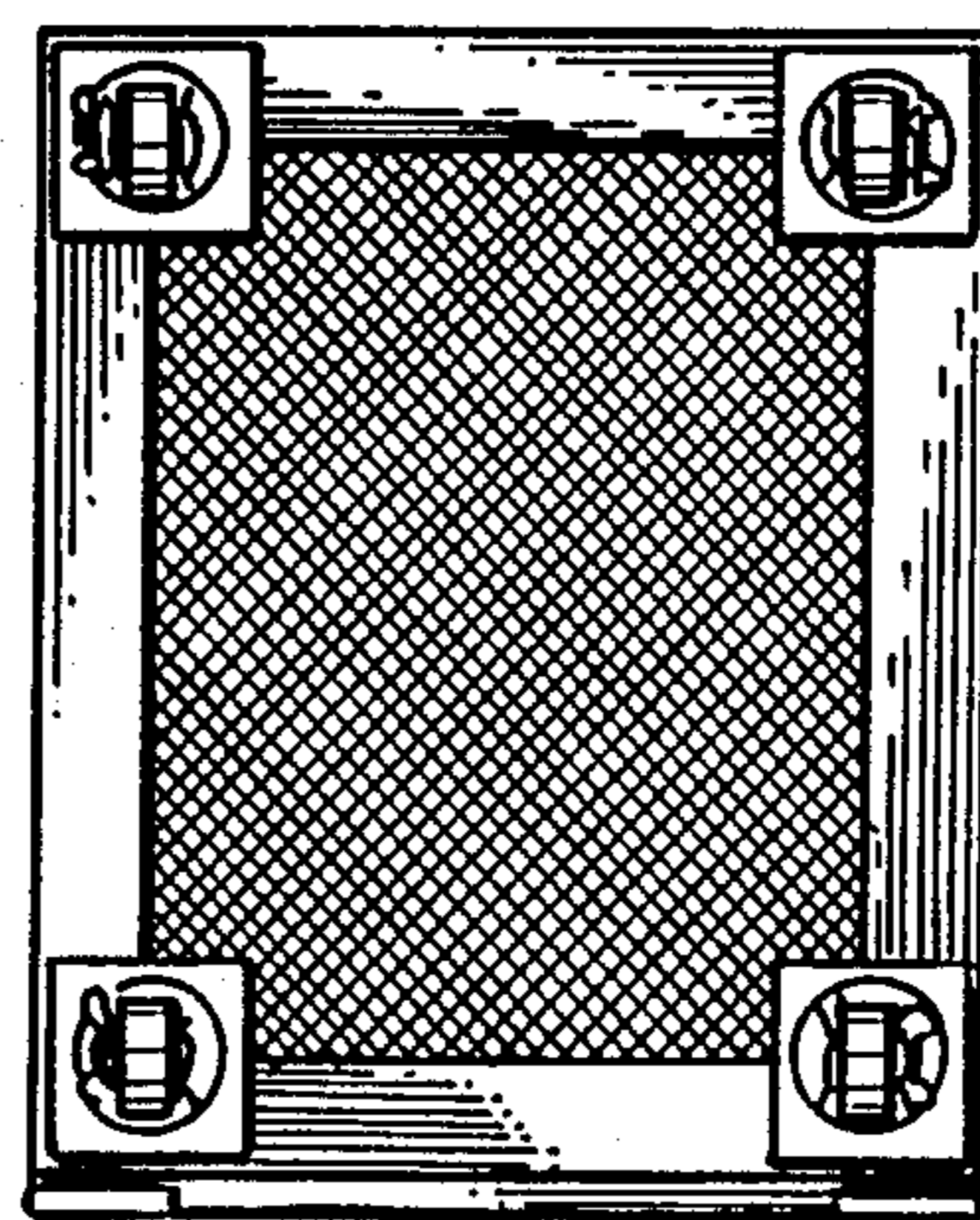

FIG. 7