

[54] GUITAR NUT

[76] Inventors: Thomas D. Sirmon, 5450 Churchill Downs, Theodore, Ala. 36582; Roger E. Fritz, Jr., 103 N. Rhonda Dr., Mobile, Ala. 36608

[**] Term: 14 Years

[21] Appl. No.: 299,212

[22] Filed: Jan. 19, 1989

[52] U.S. Cl. D17/21; D17/20; 84/307

[58] Field of Search D17/21, 14, 99, 20; 84/267, 290, 298, 299, 307, 314 R, 314 N

[56] References Cited

U.S. PATENT DOCUMENTS

D. 222,110	9/1971	Rendell	D17/21
D. 255,803	7/1980	Leal	D17/14
D. 290,017	5/1987	Edwards	D17/21
D. 299,217	10/1987	Giron, III	D17/19
1,599,184	9/1926	Polychronis	84/314 N
3,178,985	4/1965	Jeranson	84/307
3,429,214	2/1969	Jones, Sr.	84/314 N

FOREIGN PATENT DOCUMENTS

224708 7/1985 German Democratic Rep. ... 84/307

452570 8/1936 United Kingdom 84/299

Primary Examiner—Bernard Ansher
Assistant Examiner—Adir Aronovich
Attorney, Agent, or Firm—Joel Stearman

[57] CLAIM

The ornamental design for a guitar nut, substantially as shown and described.

DESCRIPTION

FIG. 1 is a perspective view of a guitar nut showing our new design:

FIG. 2 is a front elevational view thereof;

FIG. 3 is a left side elevational view, the right side elevational view being a mirror image thereof;

FIG. 4 is a perspective view of a second modified form of our new design for a guitar nut as embodied in a five-string nut;

FIG. 5 is a perspective view of third modified form of our new design for a guitar nut as embodied in a four-string nut; and

FIG. 6 is a reduced scale perspective view of the guitar nut on a fragmentary portion of a guitar neck shown in broken lines for purposes of illustrating the environment.

The bottom of the guitar nut, not shown, is substantially planar and non-ornamented.

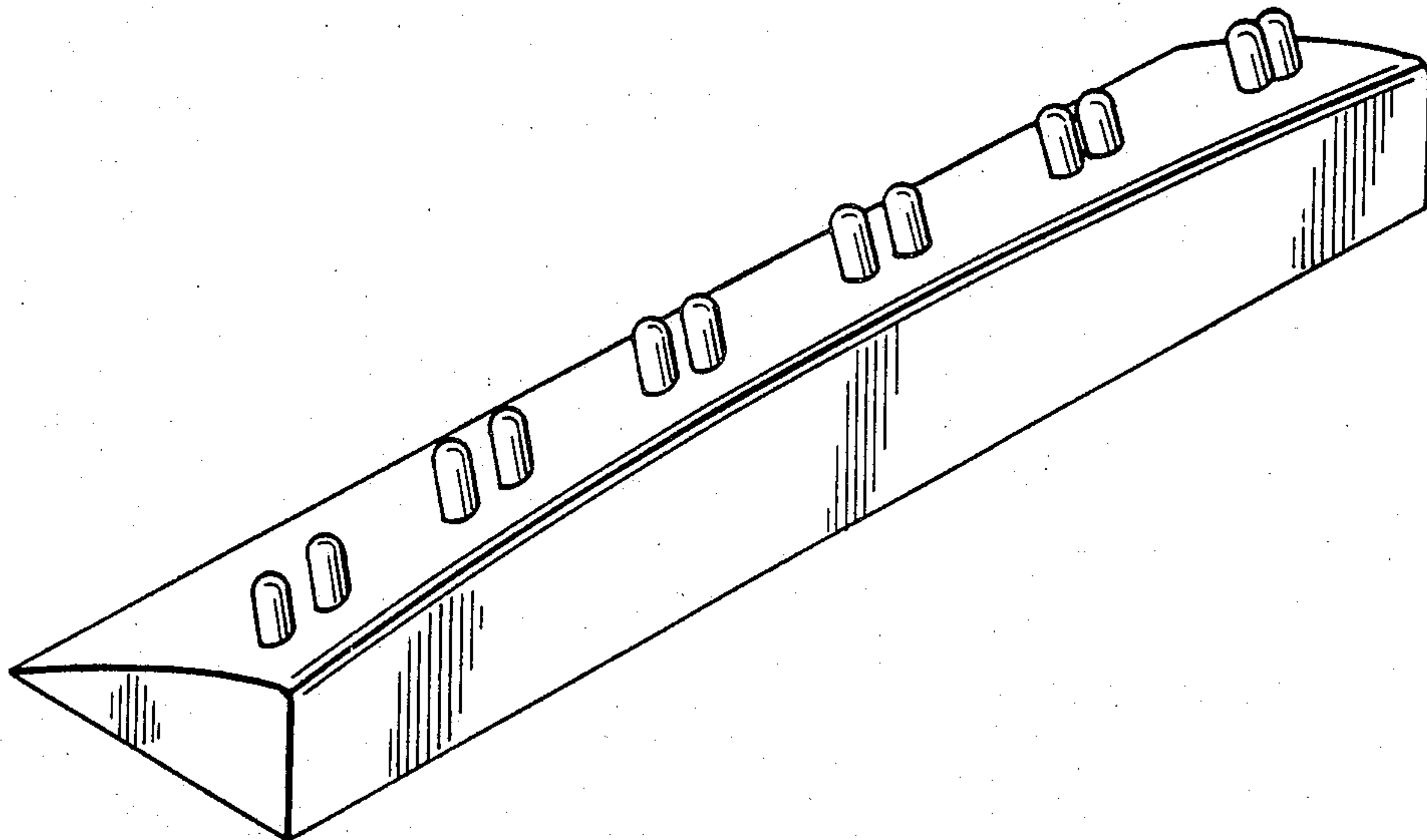

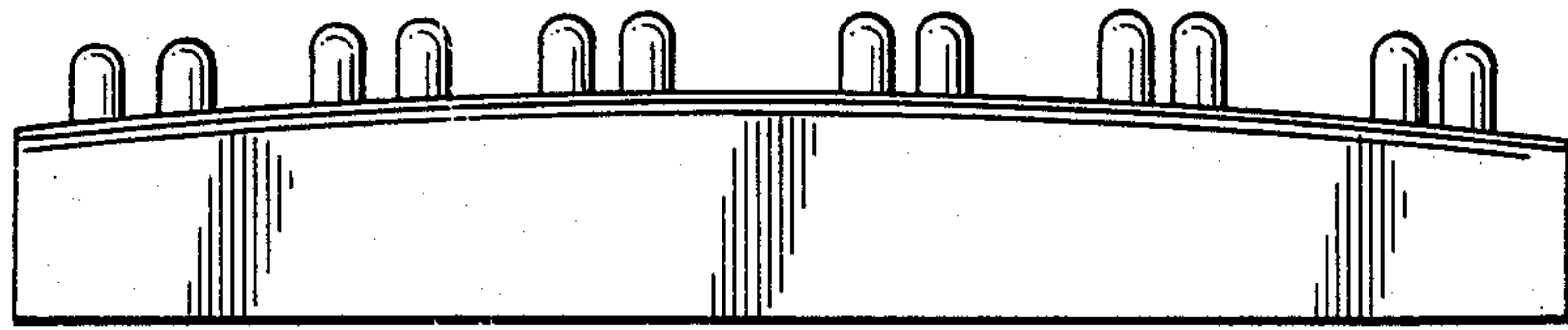
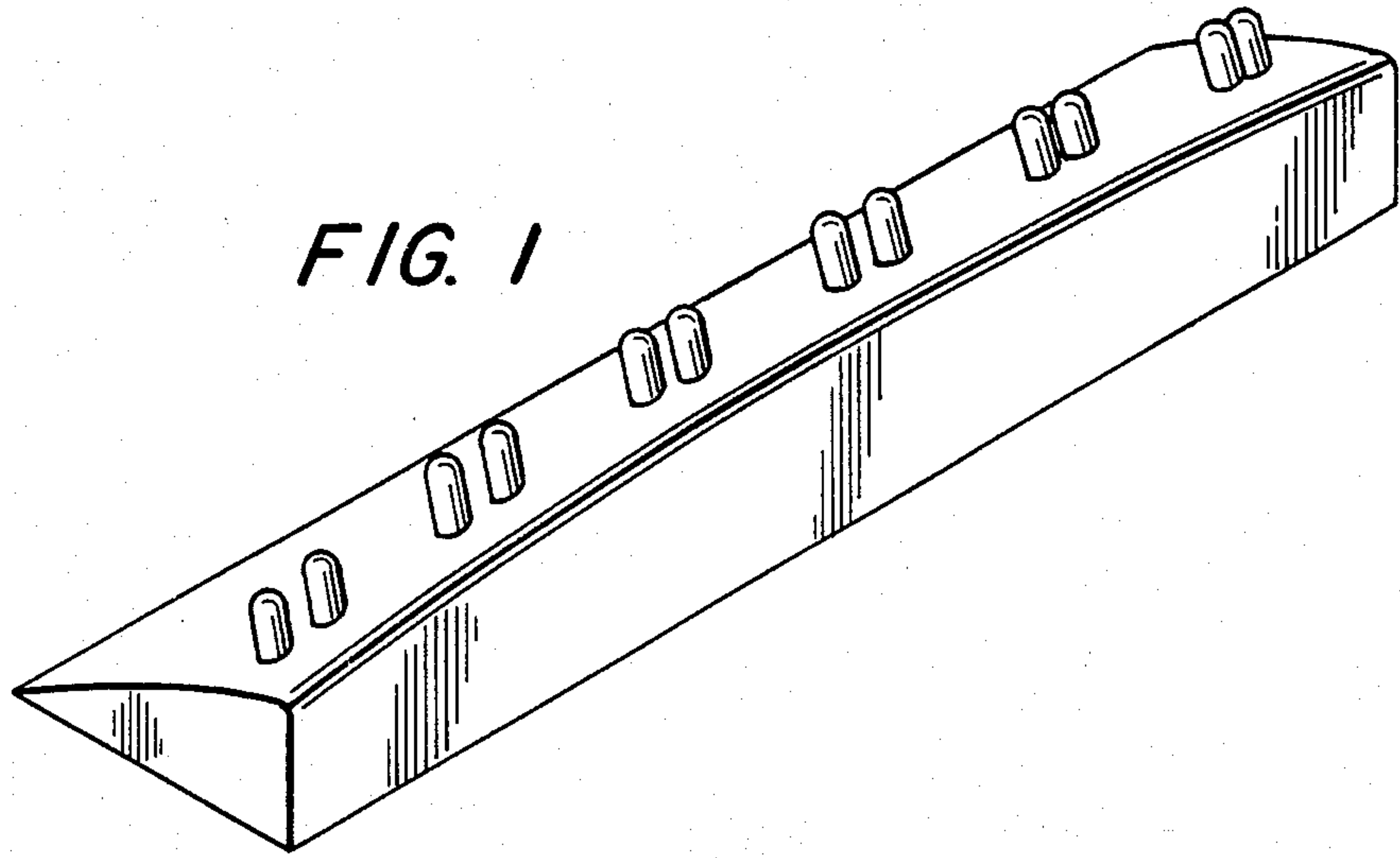

FIG. 2

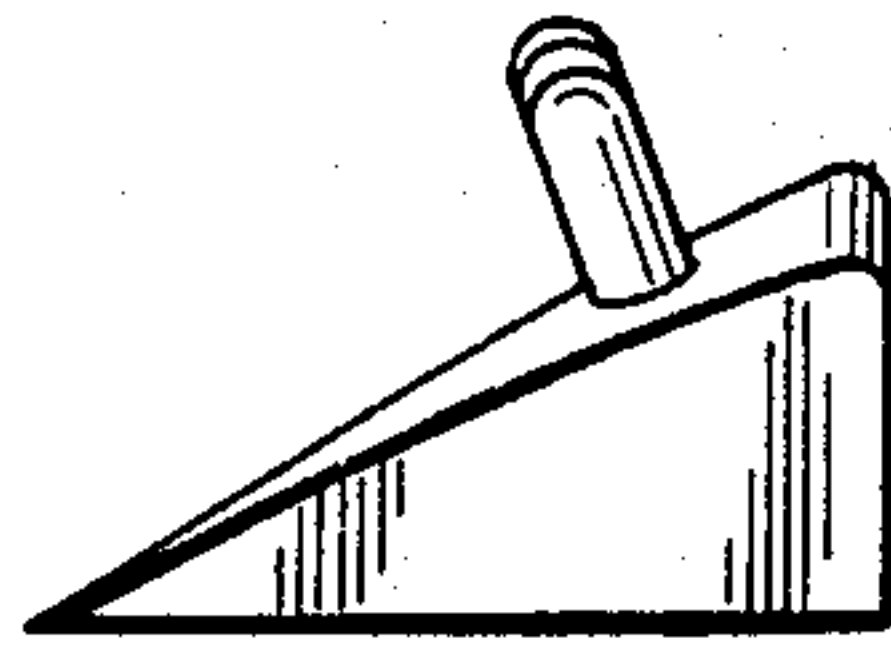

FIG. 3

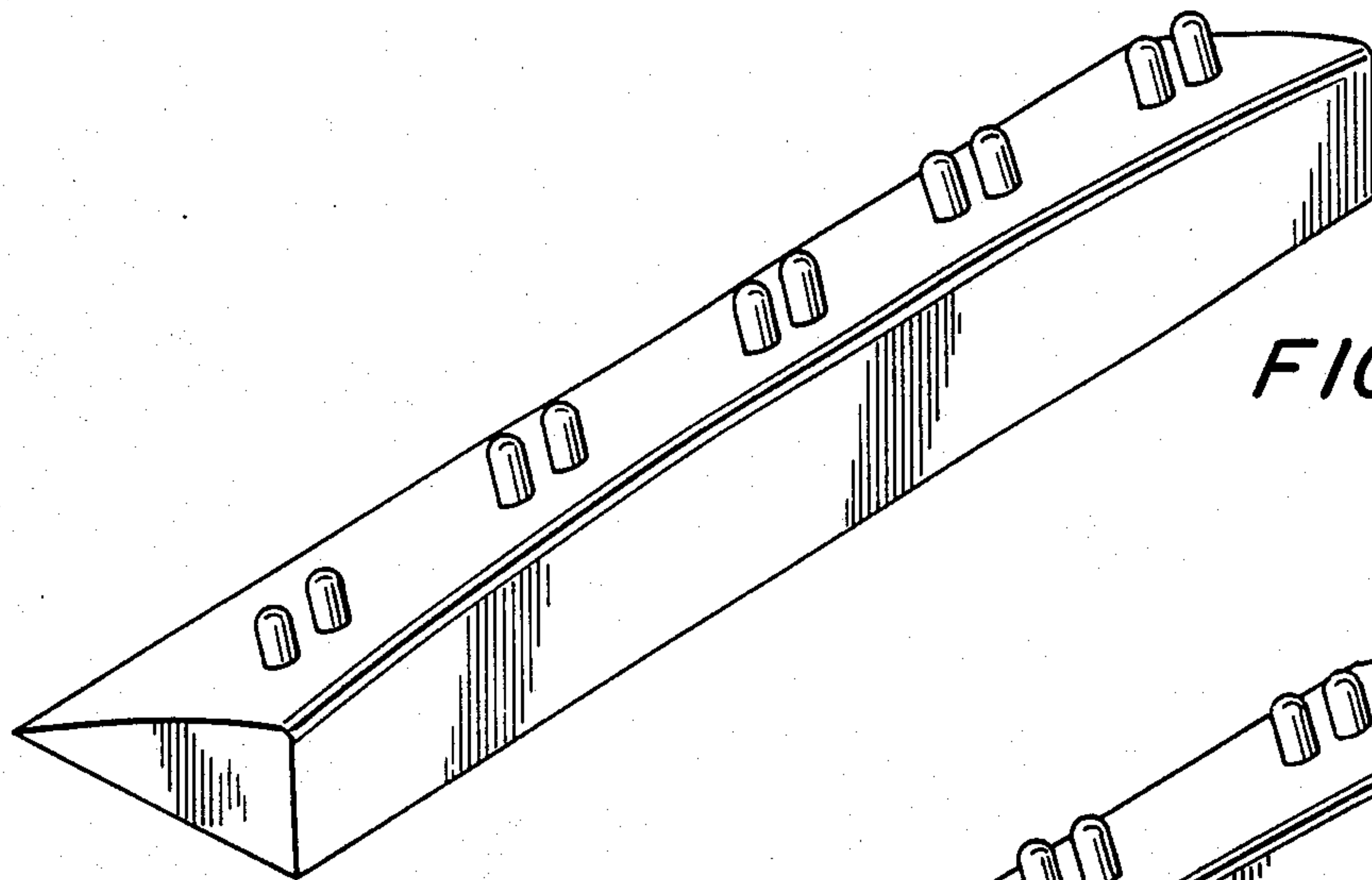

FIG. 4

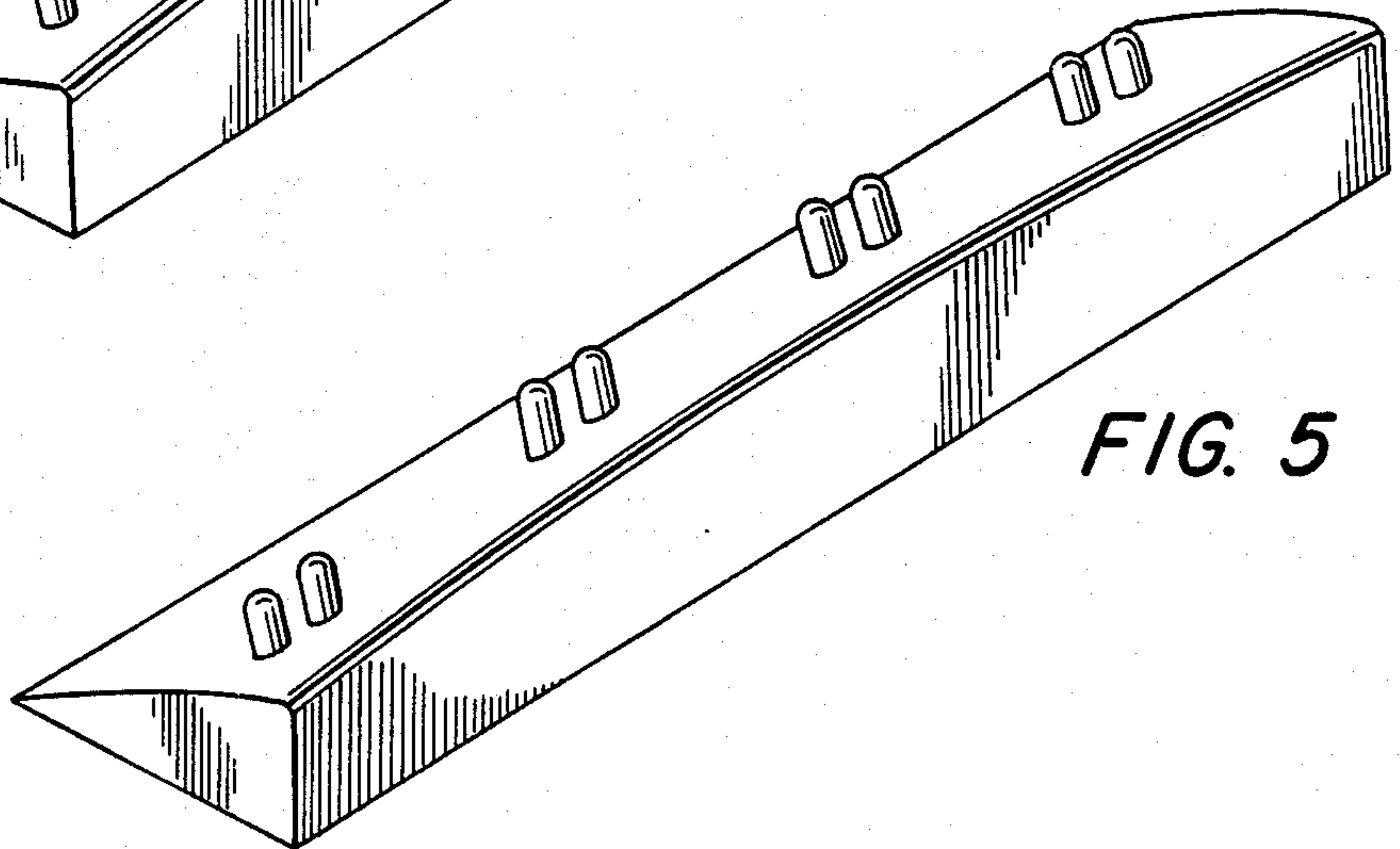

FIG. 5

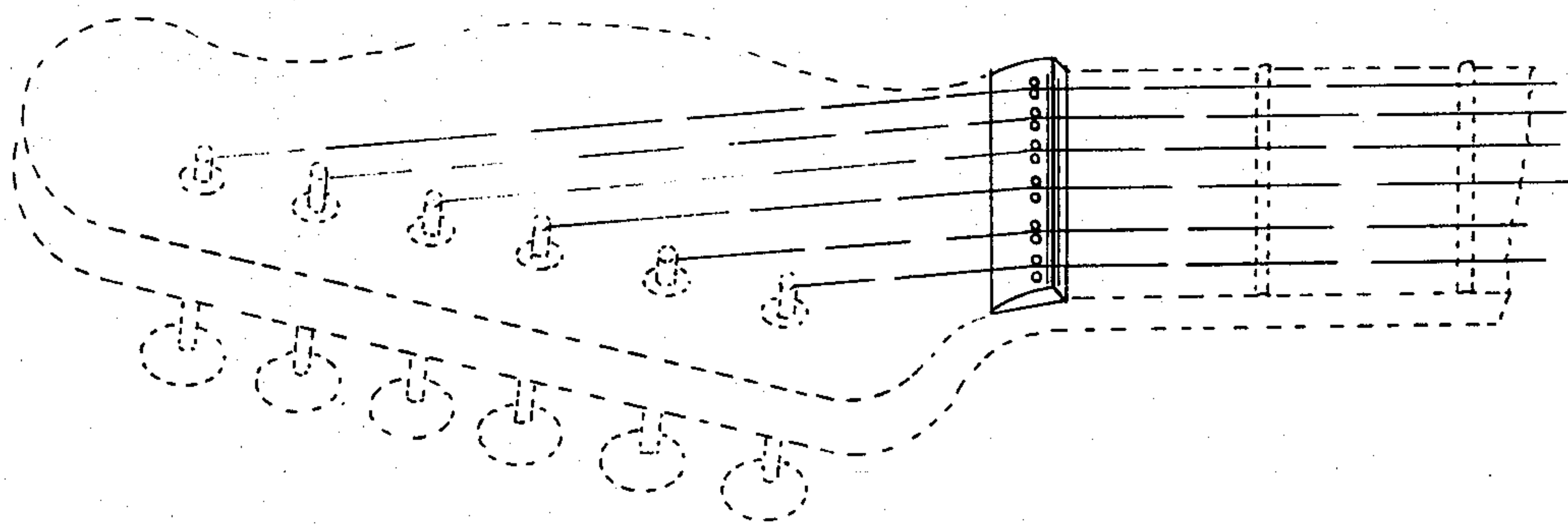

FIG. 6