

[54] **FRICTION WELDING TOOL FOR THERMOPLASTIC STRAPS OR SIMILAR ARTICLE**

3,442,733	5/1969	Vilcins	156/73.5
3,554,845	1/1971	Billett et al.	156/73.5
3,654,033	4/1972	Angarola et al.	156/494
4,096,019	6/1978	Lehmann	156/494

[75] Inventor: Franklin F. Niedrig, Berikon, Switzerland

Primary Examiner—Bruce W. Dunkins
Assistant Examiner—Clare E. Heflin
Attorney, Agent, or Firm—Werner W. Kleeman

[73] Assignee: Strapex AG, Wohlen, Switzerland

[**] Term: 14 Years

[57] **CLAIM**

[21] Appl. No.: 816,069

The ornamental design for a friction welding tool for thermoplastic straps or similar article, as shown and described.

[22] Filed: Jan. 3, 1986

[30] **Foreign Application Priority Data**

Jul. 10, 1985 [CH] Switzerland 114644

[52] U.S. Cl. D15/145; D15/144

[58] Field of Search D8/51, 68; D15/144, D15/145, 146; 156/73.5, 494, 579

DESCRIPTION

FIG. 1 is a front and left side perspective view of the friction welding tool for thermoplastic straps or similar article showing my new design;

FIG. 2 is a rear, bottom and right side perspective view thereof;

FIG. 3 is a top, left side perspective view thereof;

FIG. 4 is a top, right side perspective view thereof;

FIG. 5 is a top plan view thereof; and

FIG. 6 is a front perspective view thereof.

[56] **References Cited**

U.S. PATENT DOCUMENTS

2,982,069 5/1961 England 156/494

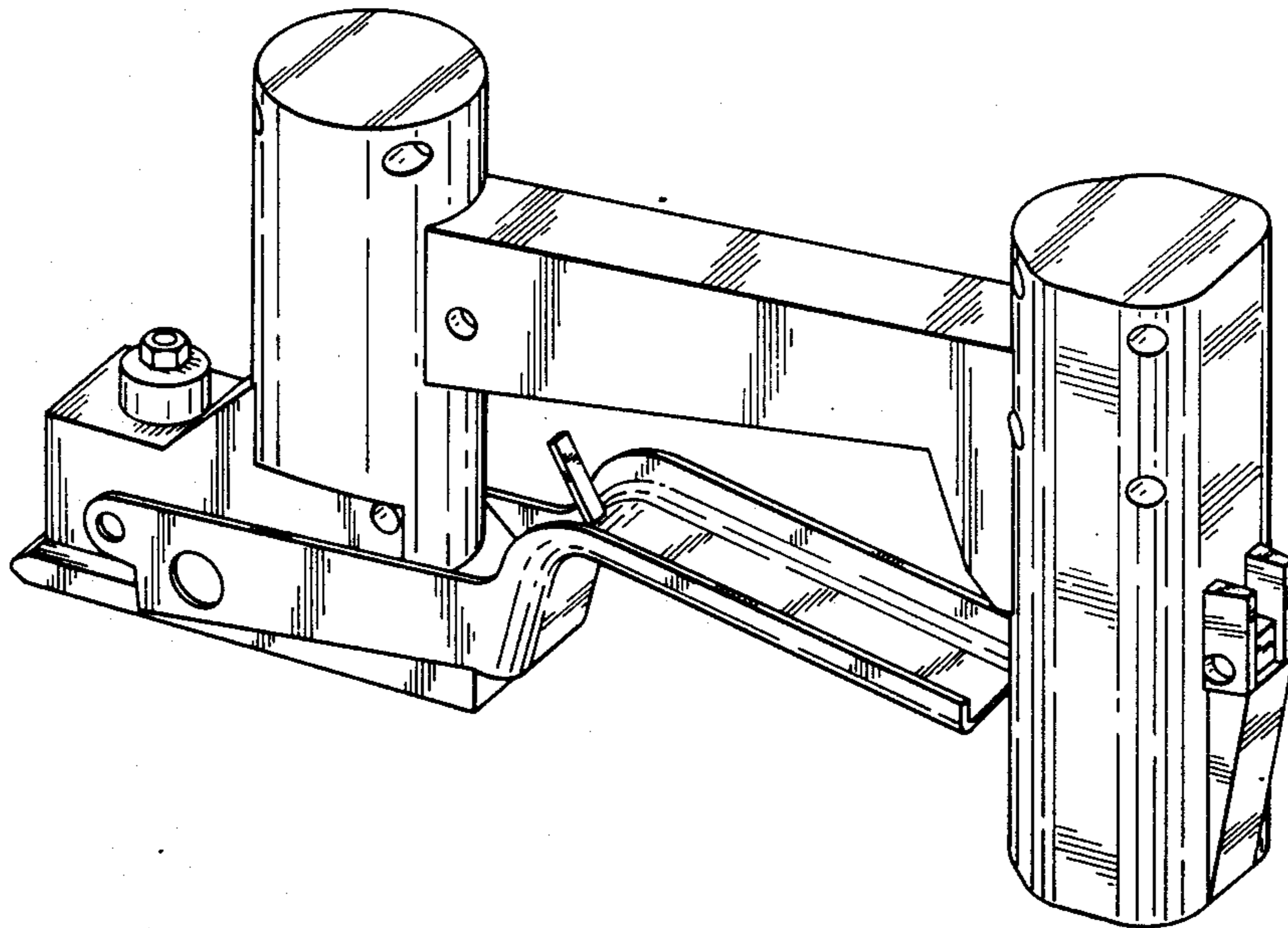

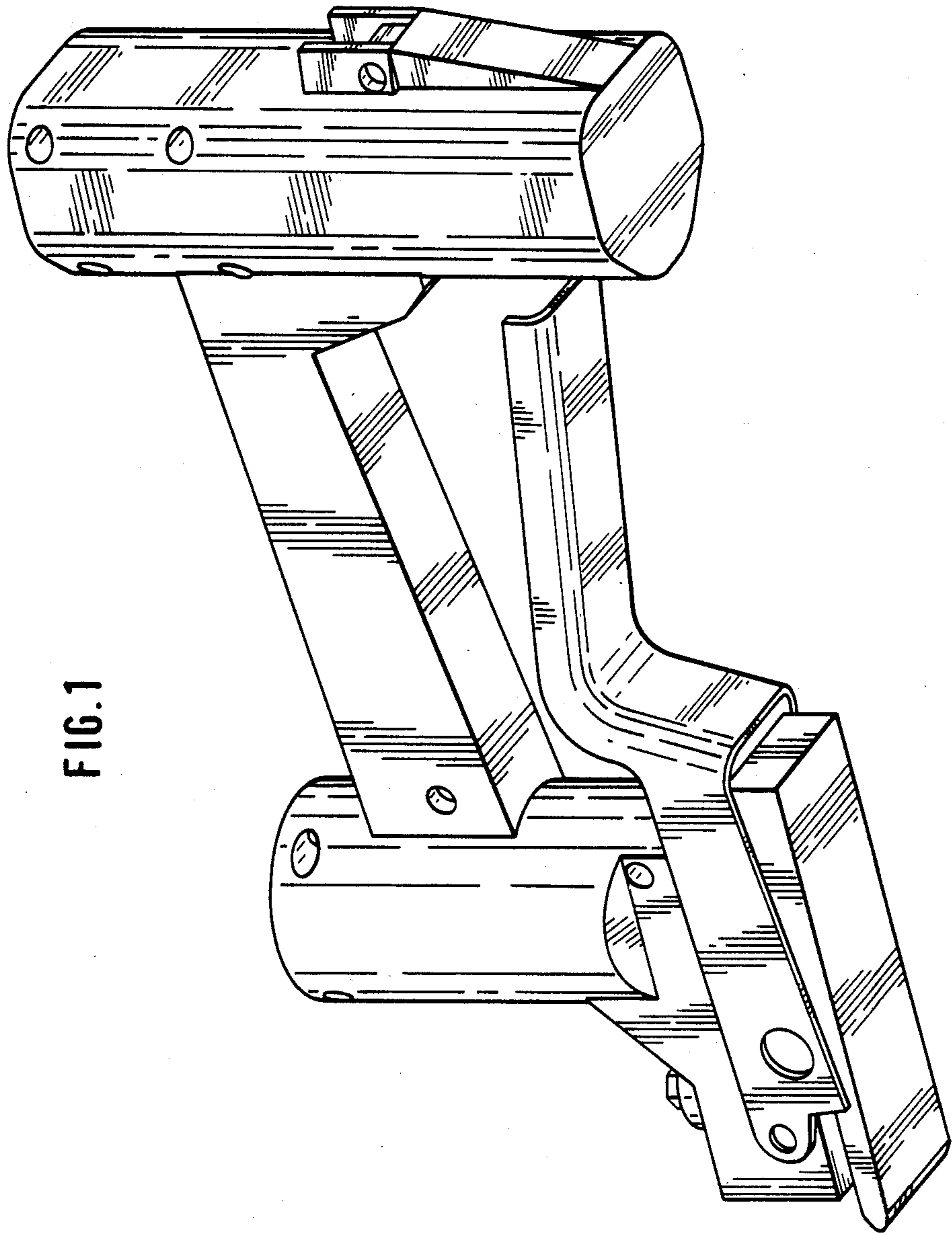

FIG. 1

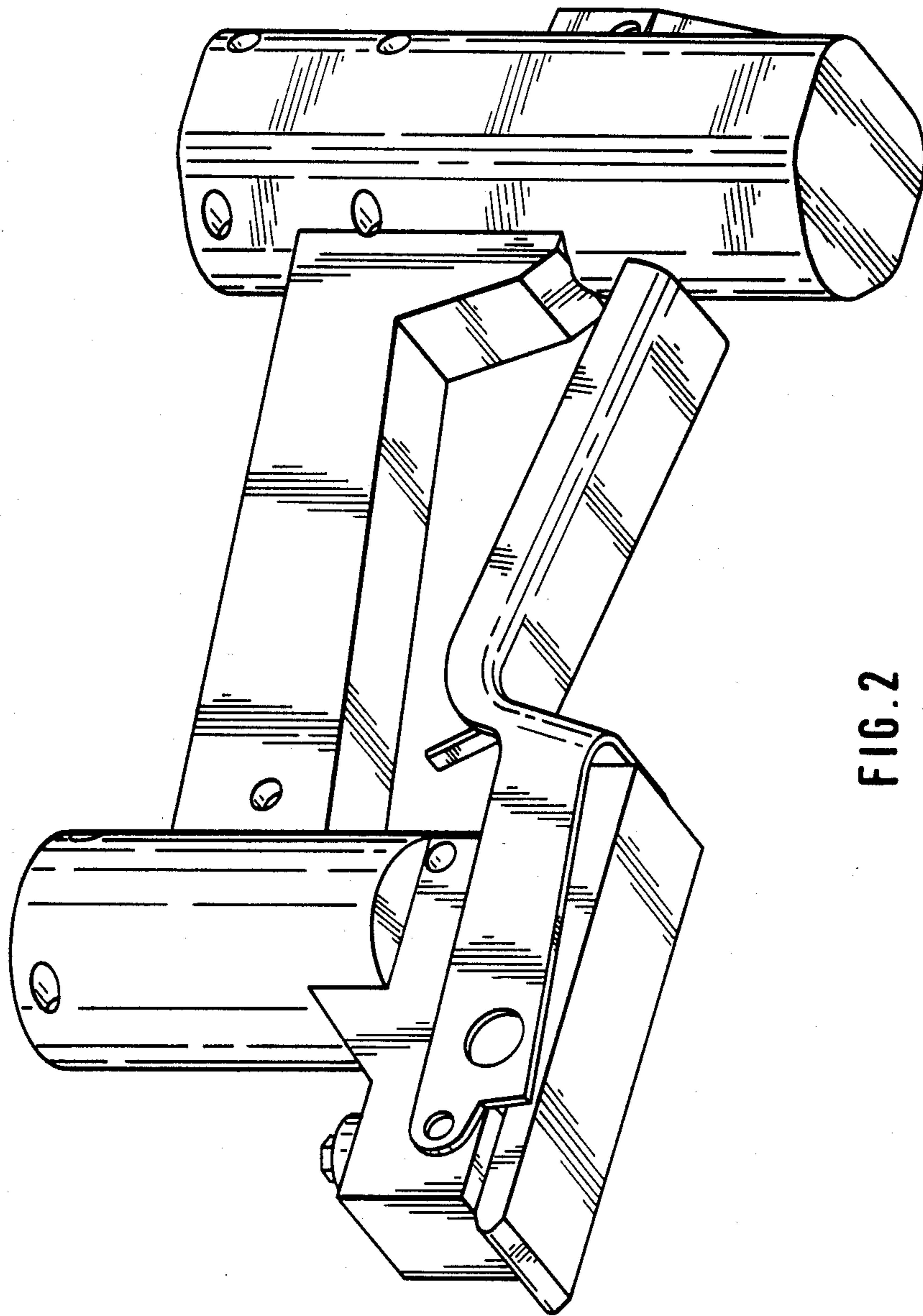

FIG. 2

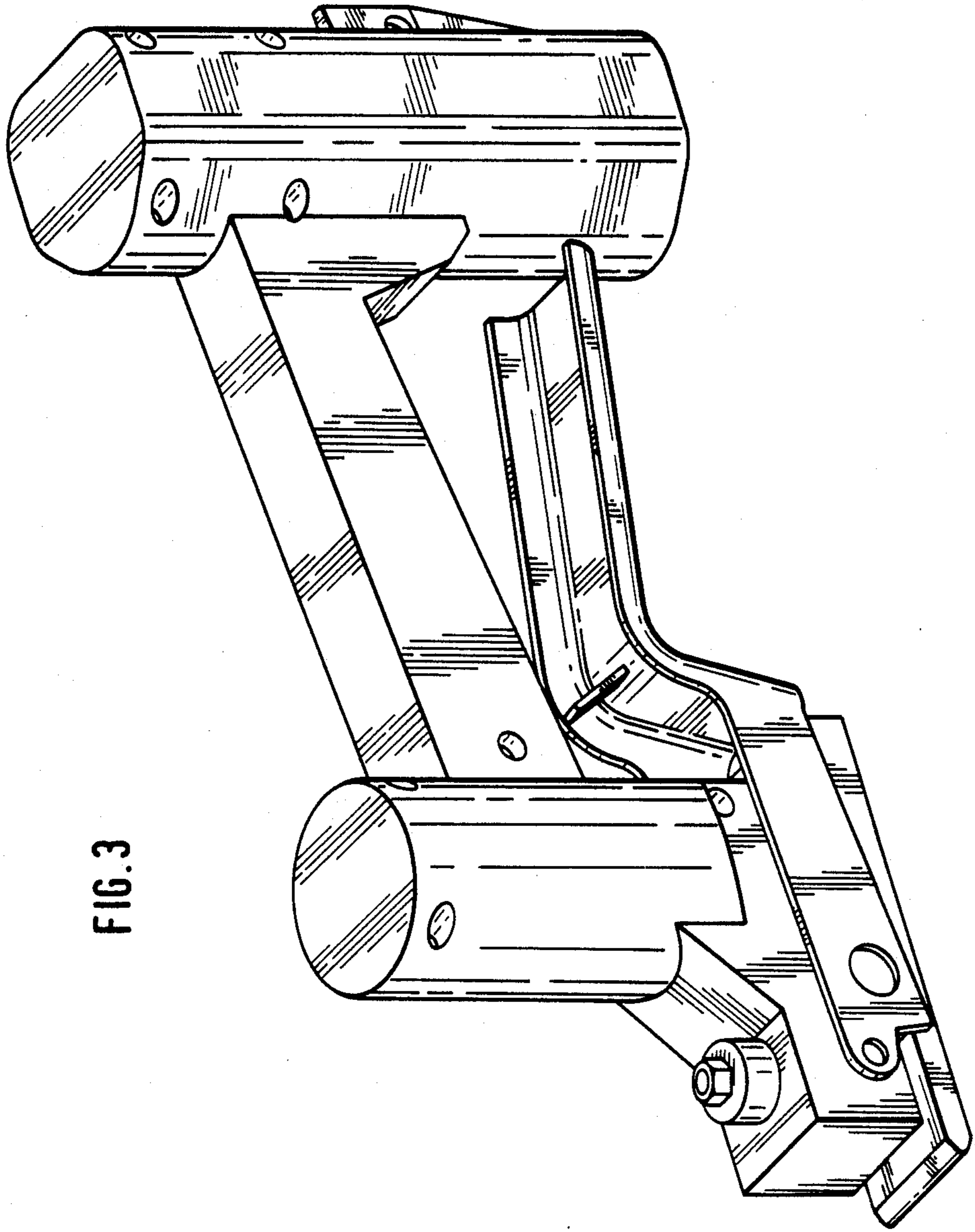

FIG. 3

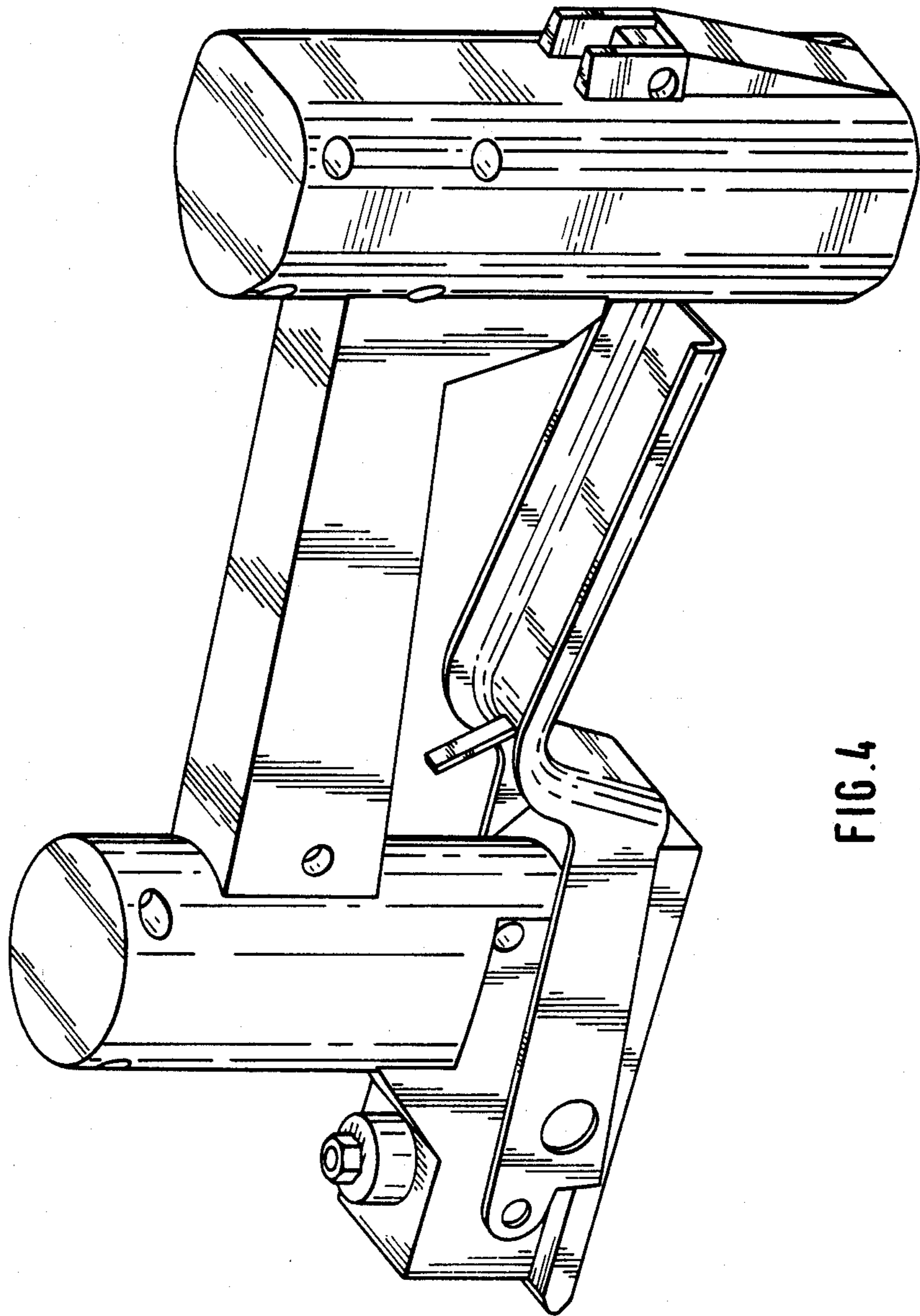

FIG. 4

FIG. 5

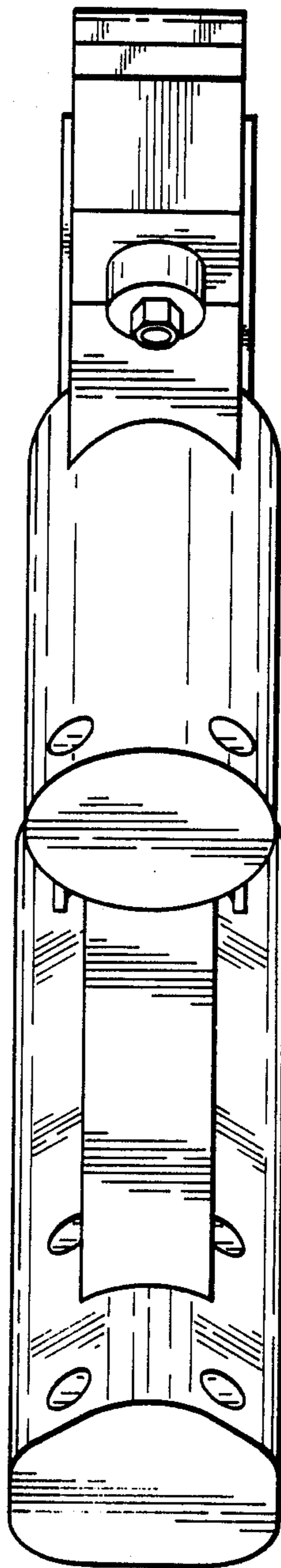

FIG. 6

