

[54] **TUBINE ROTOR**

[75] Inventor: **Robert E. Hall, Wichita, Kans.**

[73] Assignee: **Great Plains Industries, Inc.,
Wichita, Kans.**

[**] Term: **14 Years**

[21] Appl. No.: **43,233**

[22] Filed: **Apr. 27, 1987**

Related U.S. Application Data

[62] Division of Ser. No. 826,297, Feb. 5, 1986, Pat. No. 4,700,579.

[52] U.S. Cl. **D10/96; D10/103**

[58] Field of Search **D10/46, 96, 103;
73/861.78, 861.79, 861.89, 861.91-861.94;
416/292, 293**

[56]

References Cited

U.S. PATENT DOCUMENTS

D. 237,951	12/1975	Simerl	D10/96
D. 245,486	8/1977	Nishkin	D10/96
2,728,893	12/1955	Bartelink	73/861.78 X
3,053,087	9/1962	Waugh	73/861.78
4,109,526	8/1978	Rosso	73/861.78
4,700,579	10/1987	Hall	73/861.78

Primary Examiner—Nelson C. Holtje
Attorney, Agent, or Firm—Bill D. McCarthy

[57]

CLAIM

The ornamental design for a turbine rotor, as shown and described.

DESCRIPTION

FIG. 1 is a right side elevational view of a turbine rotor showing my new design, the left side view being identical when the rotor is rotated 180° on its longitudinal axis;

FIG. 2 is a top plan view of FIG. 1 the bottom plan view being identical when the rotor is rotated 180 on its longitudinal axis.

FIG. 3 is a front elevational of FIG. 1;

FIG. 4 is a rear elevational view of FIG. 1.

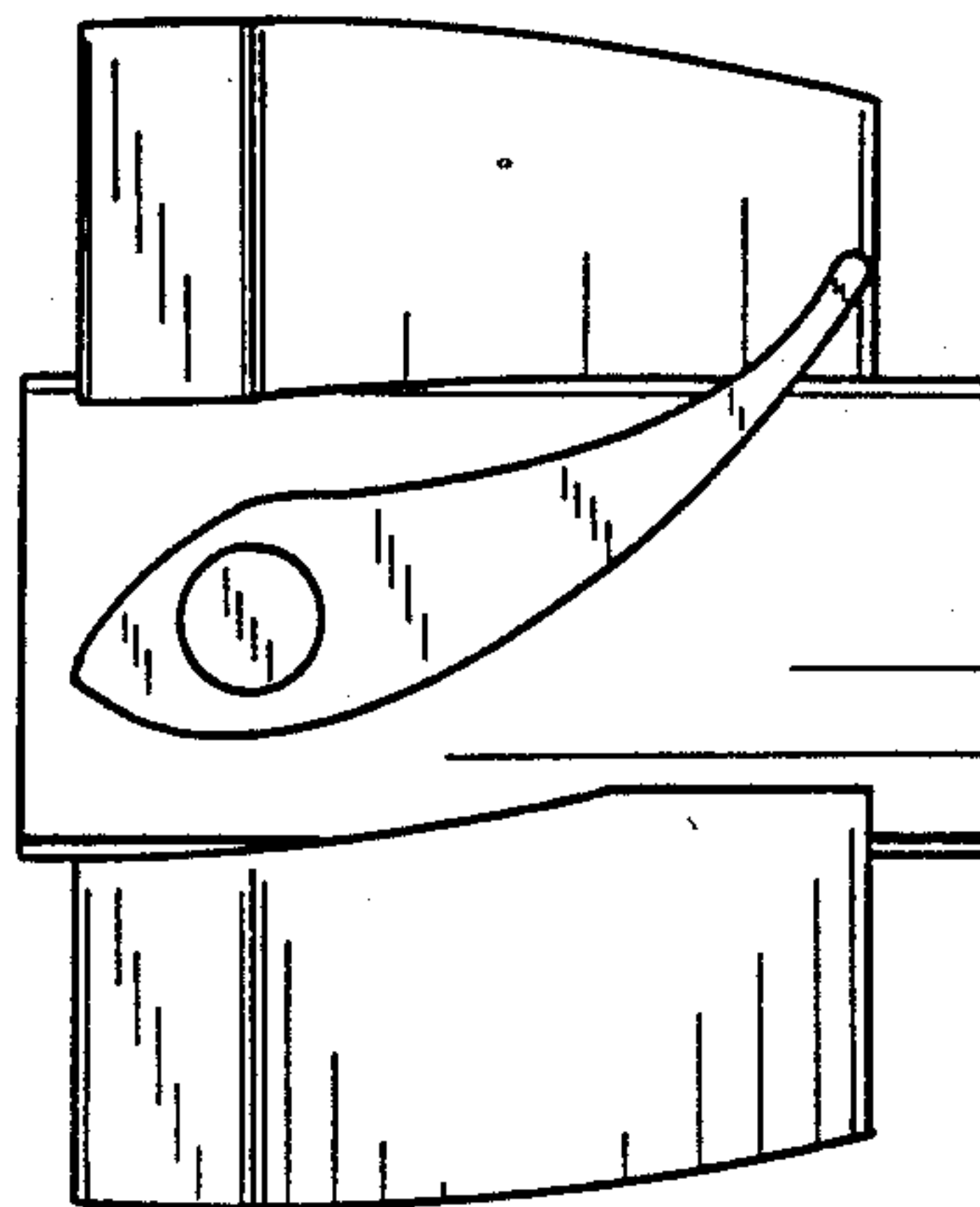

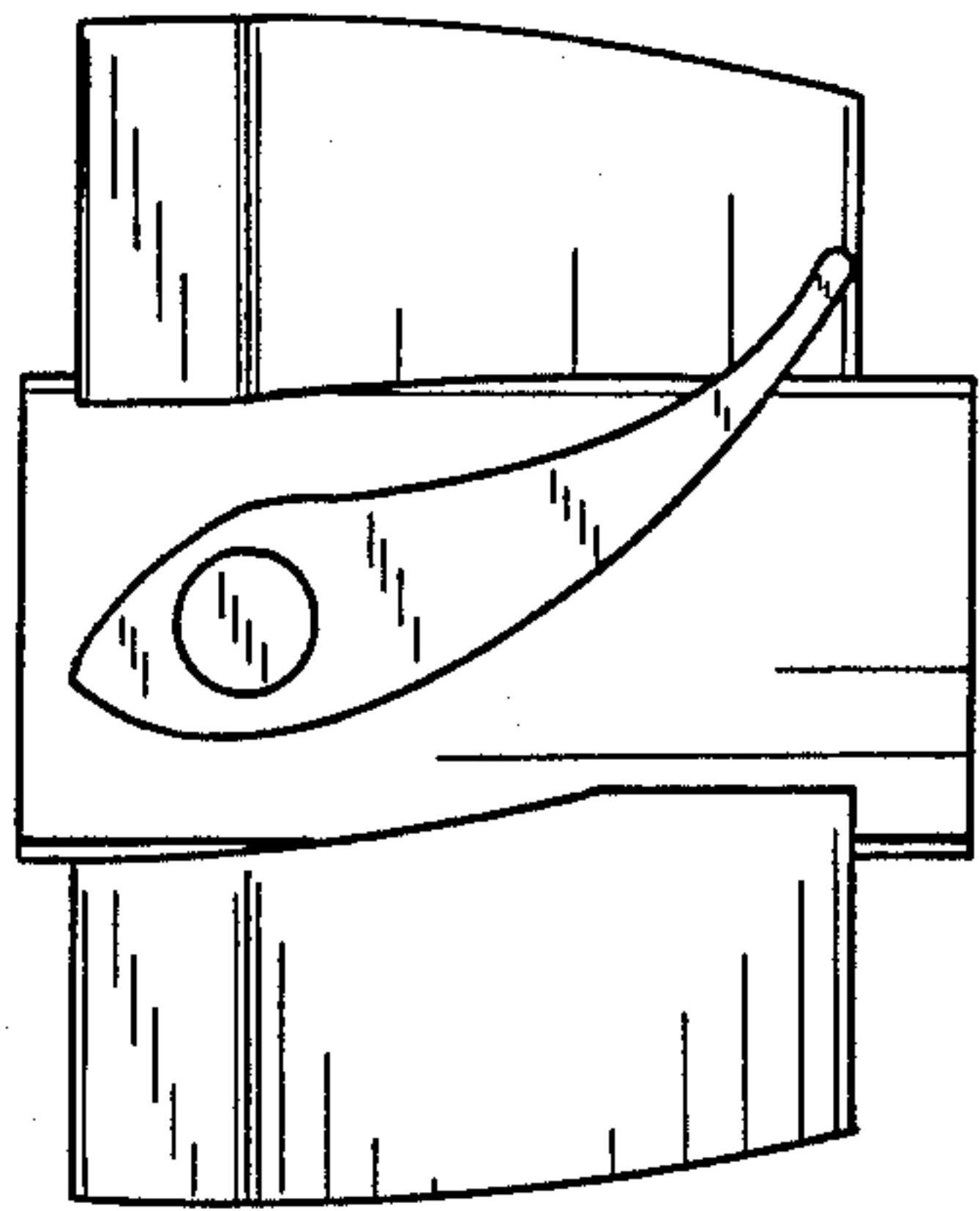

FIG. 1

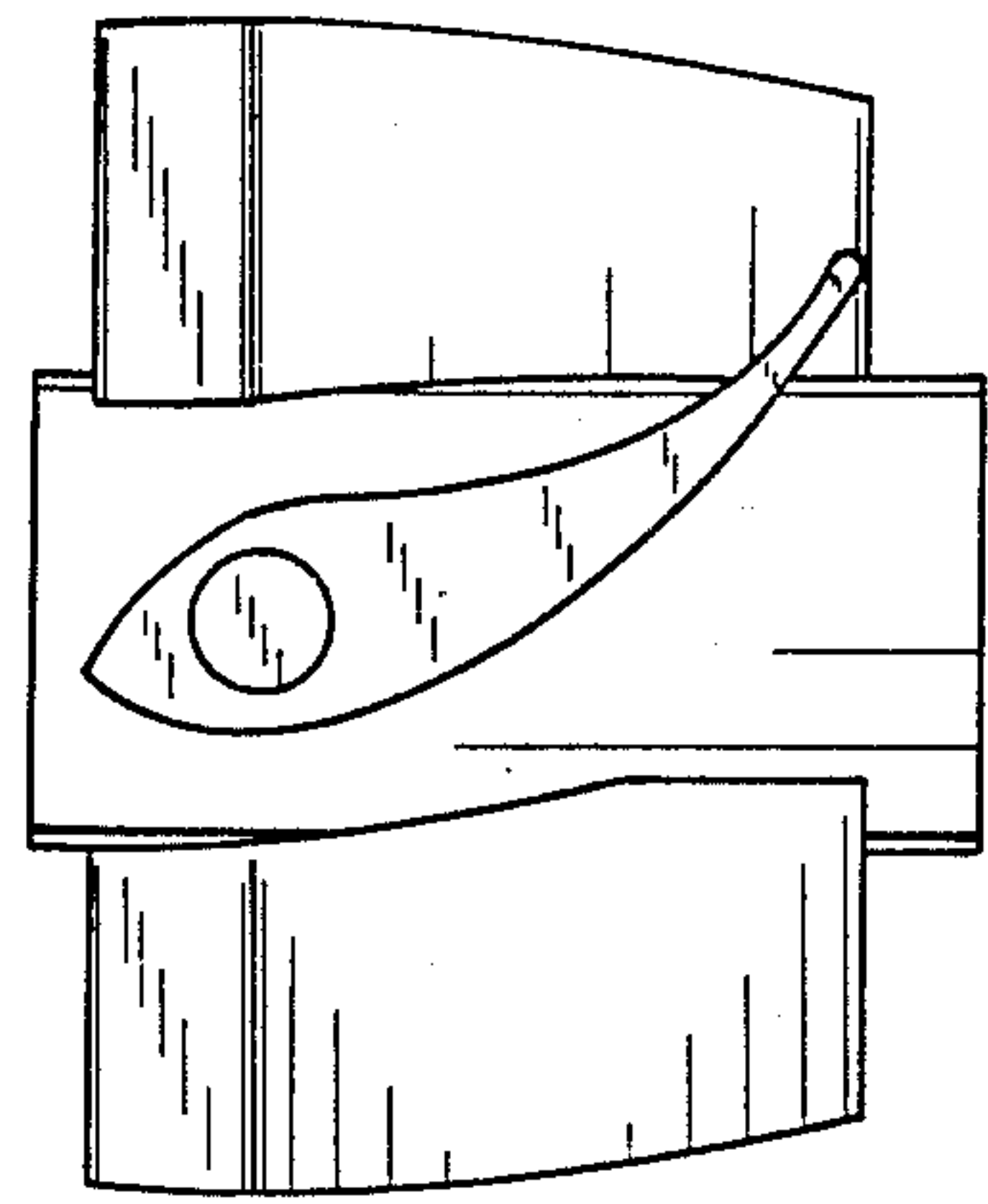

FIG. 2

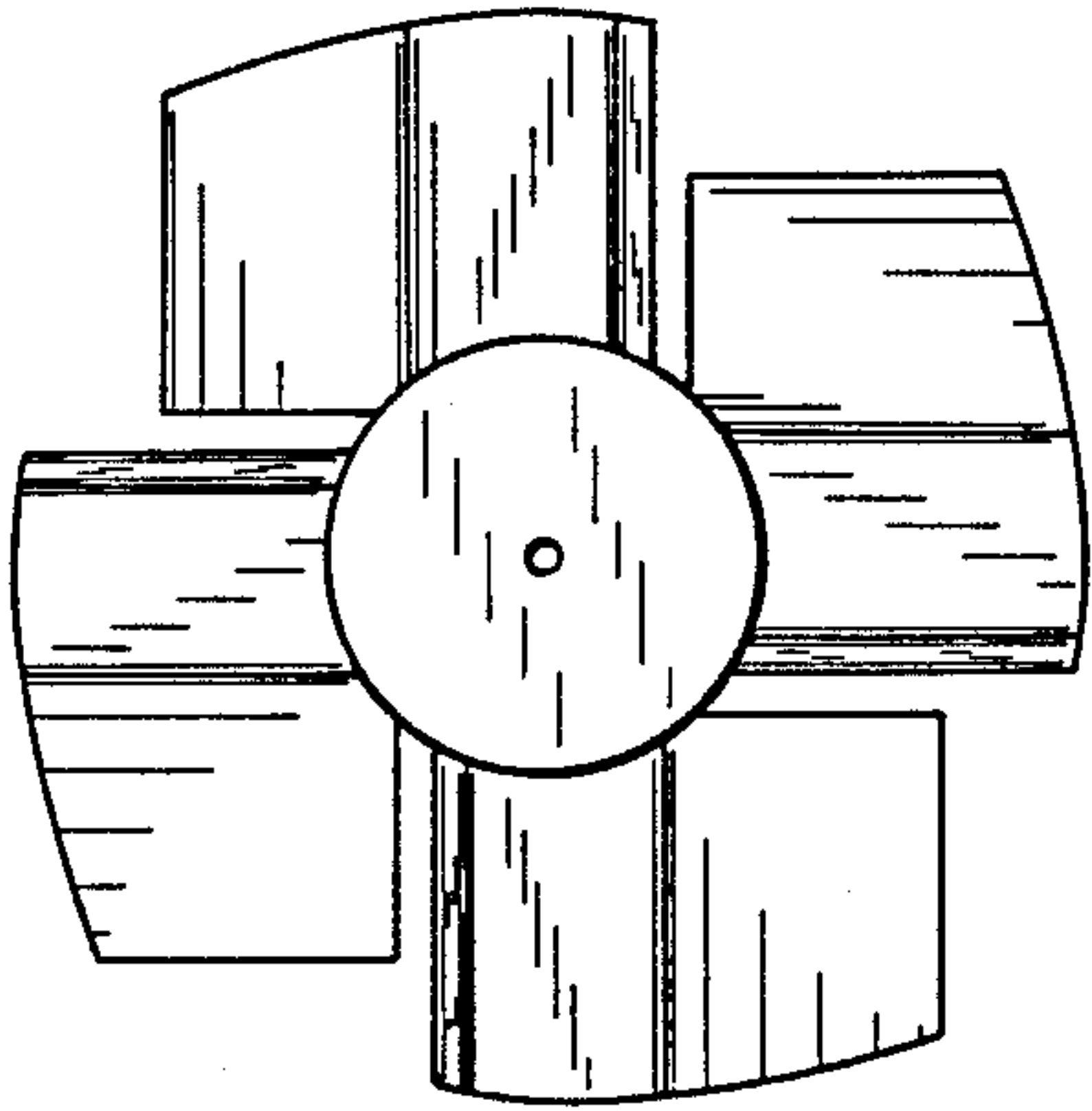

FIG. 3

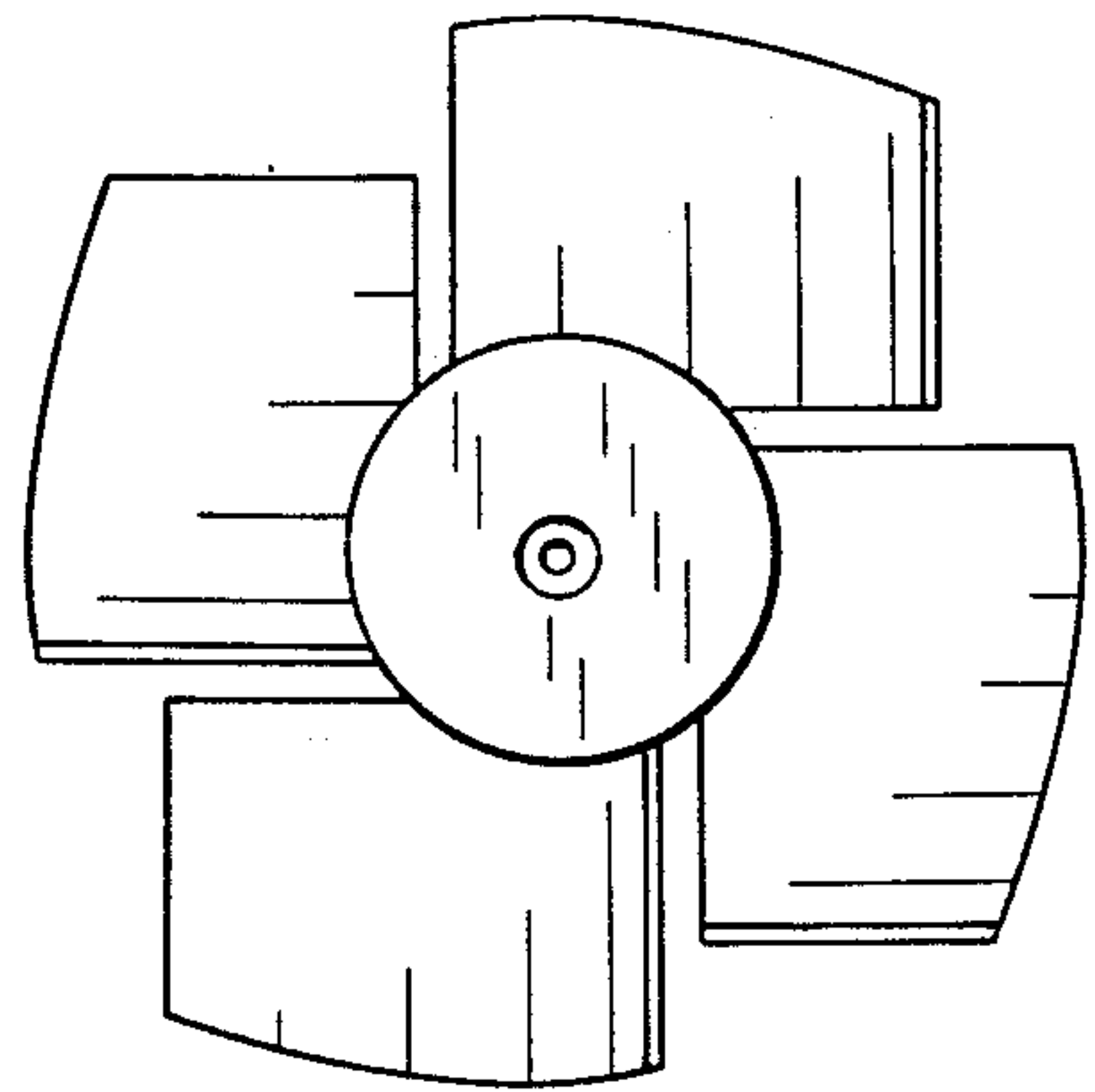

FIG. 4