

[54] POST LANTERN LAMP OR THE LIKE

[75] Inventor: John Fretz, Huntington Valley, Pa.

[73] Assignee: Thomas Industries Inc., Louisville, Ky.

[**] Term: 14 Years

[21] Appl. No.: 69,951

[22] Filed: Jul. 6, 1987

[52] U.S. Cl. D26/67

[58] Field of Search D26/67-71;
362/431, 432, 362, 363, 310

[56] References Cited

U.S. PATENT DOCUMENTS

- D. 199,142 9/1964 Daum D26/67
- D. 199,144 9/1964 Daum D26/67
- 1,545,711 7/1925 Townsend D26/68 X

OTHER PUBLICATIONS

Progress Lighting catalog 108, ©1964, p. 71, Post Lantern P 5425.

"Thomas 1971" Lighting catalog, Post Lantern.

Primary Examiner—Susan J. Lucas

Attorney, Agent, or Firm—Hill, Van Santen, Steadman & Simpson

[57] CLAIM

The ornamental design for a post lantern lamp or the like, as shown and described.

DESCRIPTION

FIG. 1 is a front elevational view of a post lantern or the like showing my new design, the rear being identical; FIG. 2 is a side elevational view thereof, the opposite side being identical; FIG. 3 is a top plan view thereof; and FIG. 4 is a bottom plan view thereof.

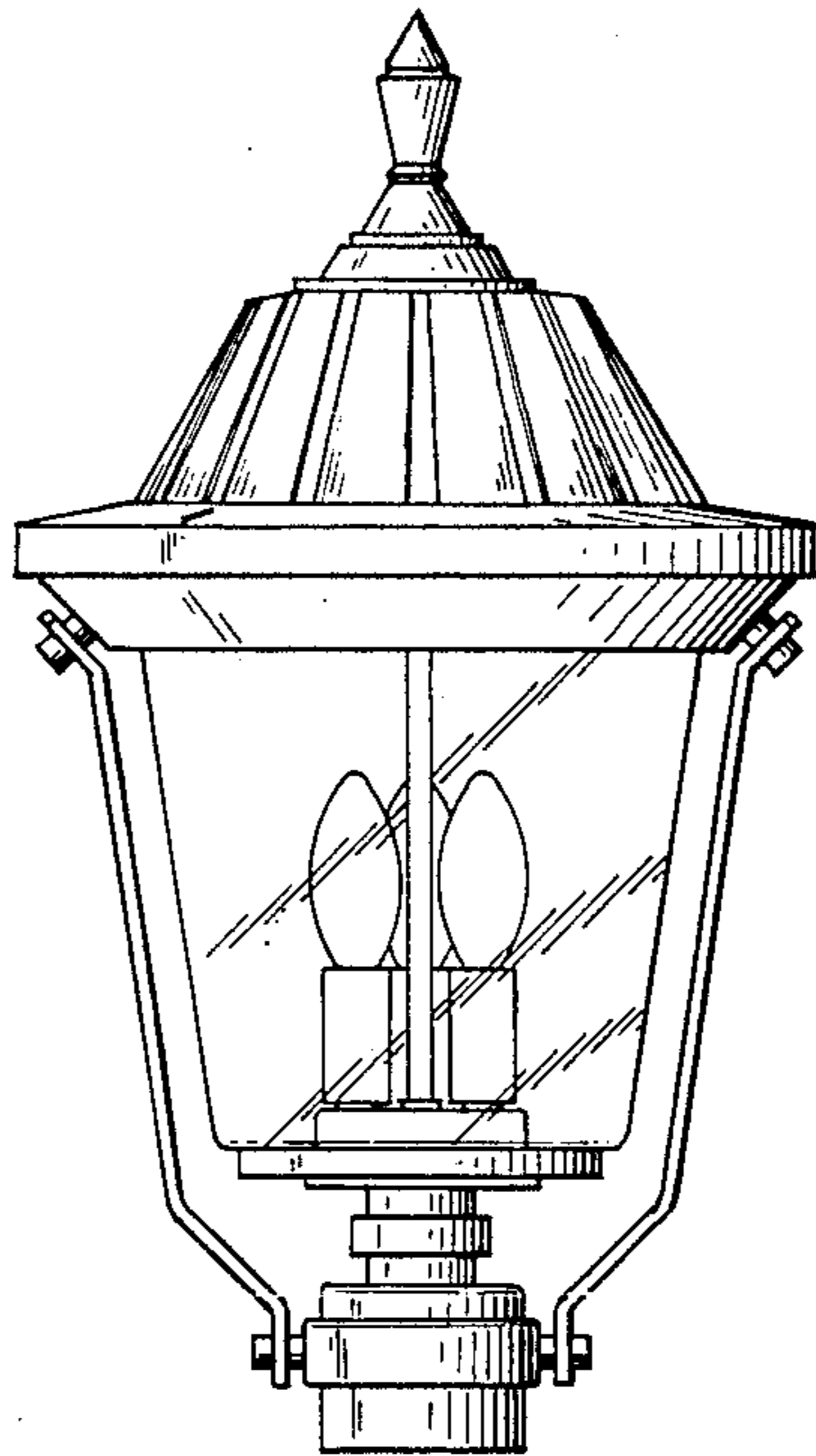

FIG. 1

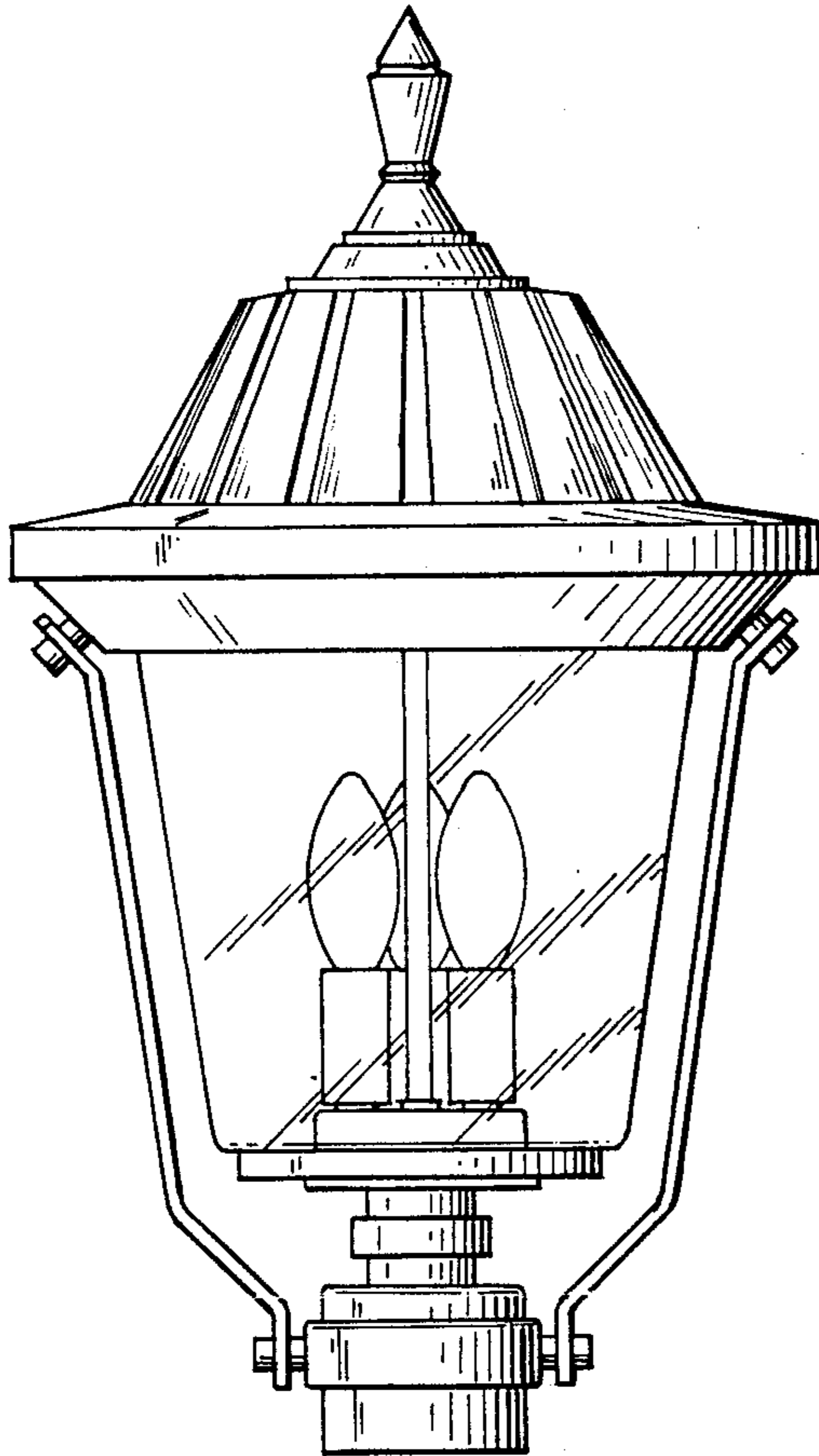

FIG. 2

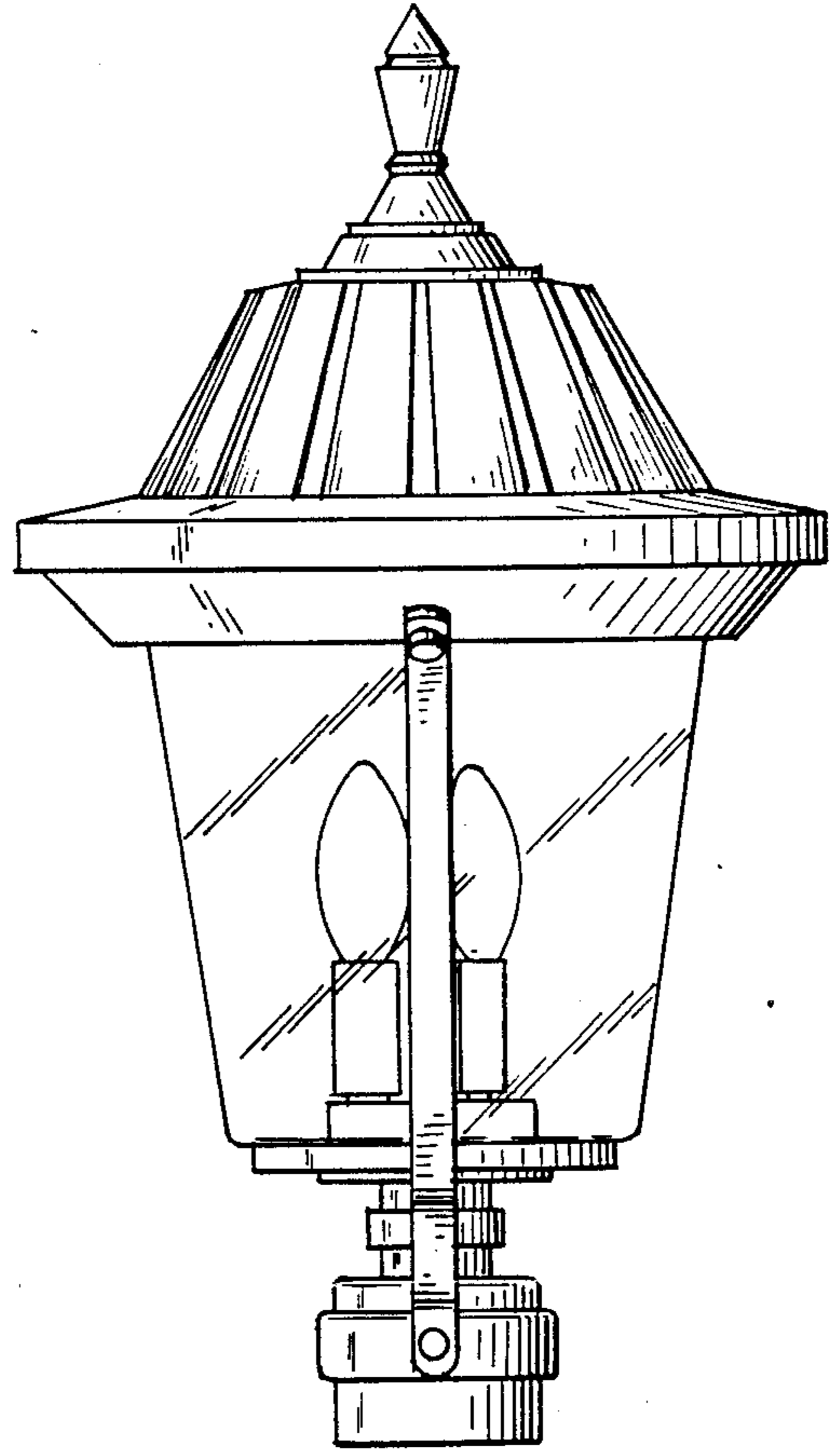

FIG. 3

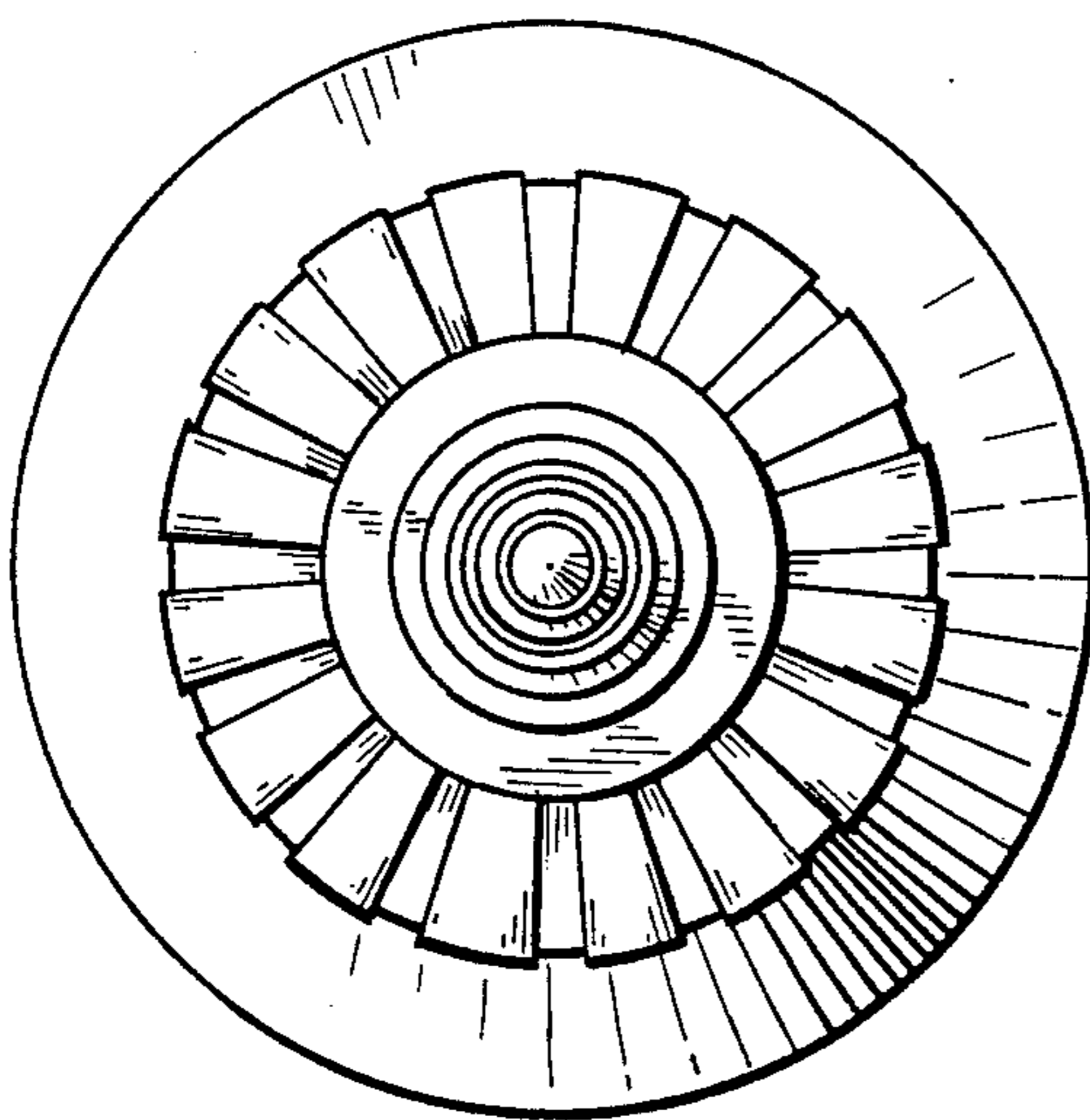

FIG. 4

