

[54] **POST LANTERN OR THE LIKE**

[75] **Inventor: Vince DiCola, Louisville, Ky.**
[73] **Assignee: Thomas Industries Inc., Louisville, Ky.**
[**] **Term: 14 Years**
[21] **Appl. No.: 69,947**

[22] **Filed: Jul. 6, 1987**
[52] **U.S. Cl. D26/67**
[58] **Field of Search D26/67-71;**
362/431, 432, 362, 363, 310

[56] **References Cited**
U.S. PATENT DOCUMENTS

D. 178,282 7/1956 De Runtz D26/67
1,545,711 7/1925 Townsend D26/68
4,434,455 2/1984 Merritt 362/431 X

OTHER PUBLICATIONS

Artolier World's Fair Lantern supplement, 1964, p. 3, Post Lantern #5031.
Custom Lighting Inc., Lighting Design & Application insert, 4-1986, p. 3, "Oriel" Post Lantern.
Home Lighting & Accessories, 7-1985, p. 45, Hadco Post Lantern L-1930.
"Thomas 1971" Lighting catalog, Lanterns.
Primary Examiner—Susan J. Lucas
Attorney, Agent, or Firm—Hill, Van Santen, Steadman & Simpson

[57] **CLAIM**

The ornamental design for a post lantern or the like, as shown and described.

DESCRIPTION

FIG. 1 is a side elevational view of a post lantern or the like showing my new design, the opposite side being identical.
FIG. 2 is a front elevational view thereof, the rear being identical.
FIG. 3 is a top plan view thereof; and
FIG. 4 is a bottom plan view thereof.

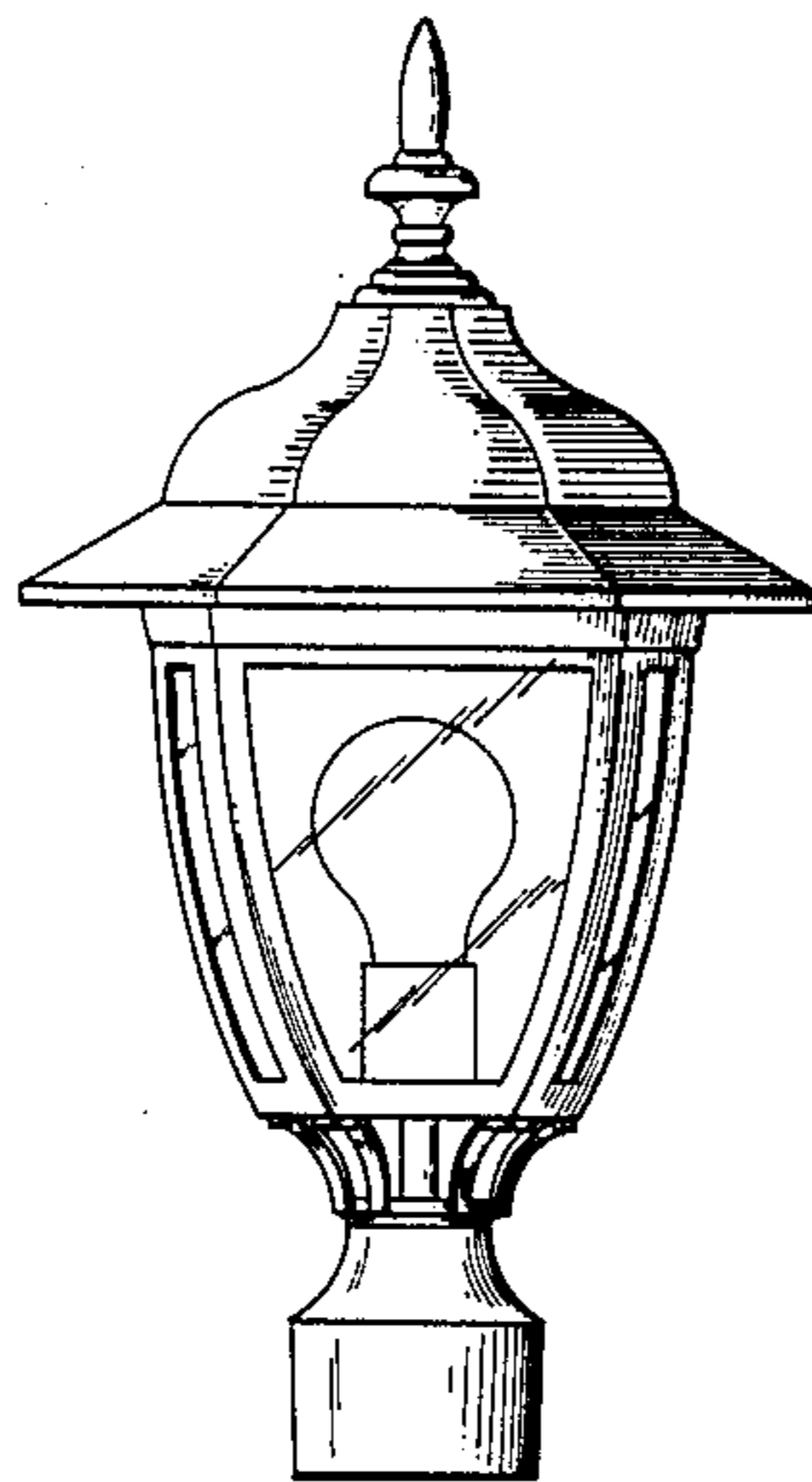

FIG.1

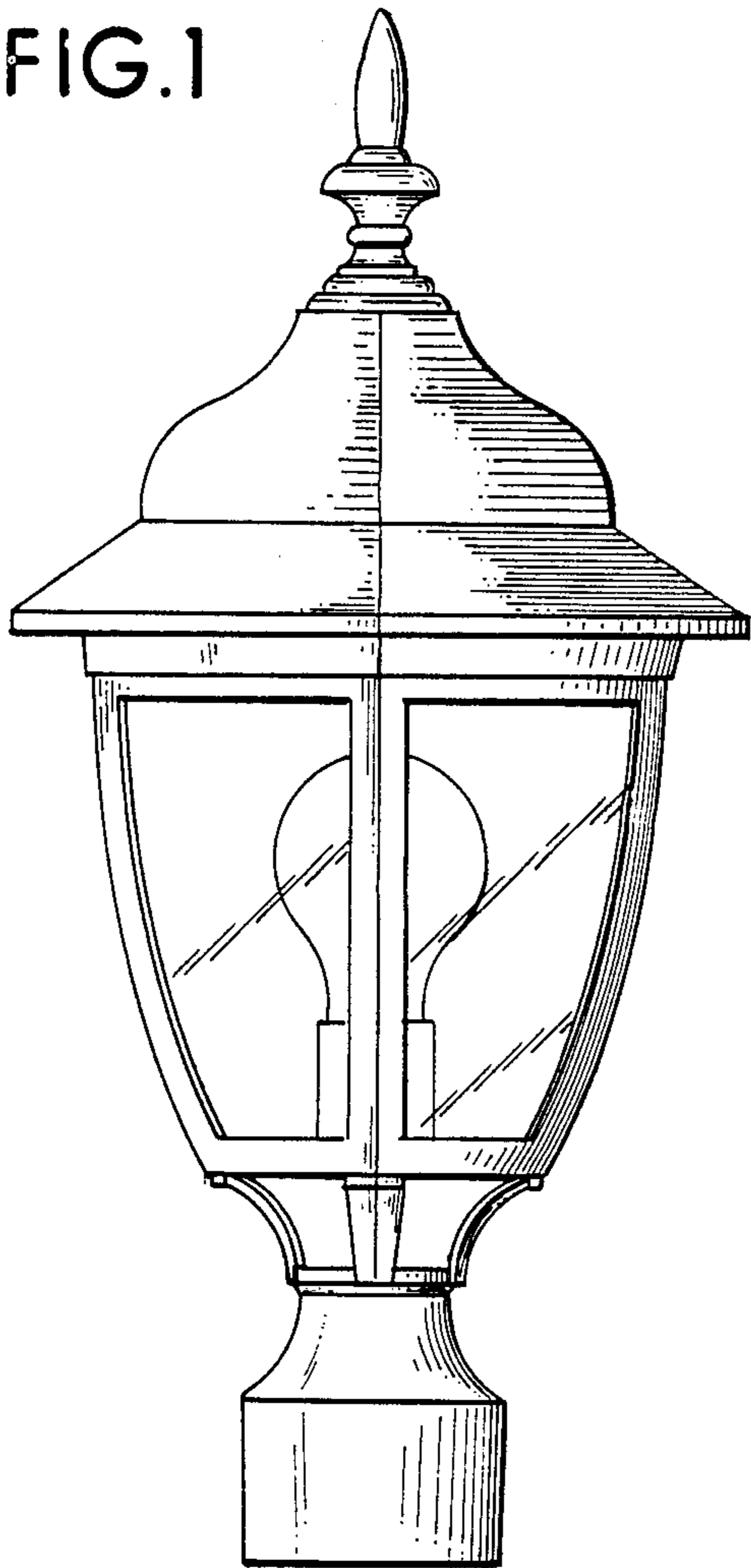

FIG.2

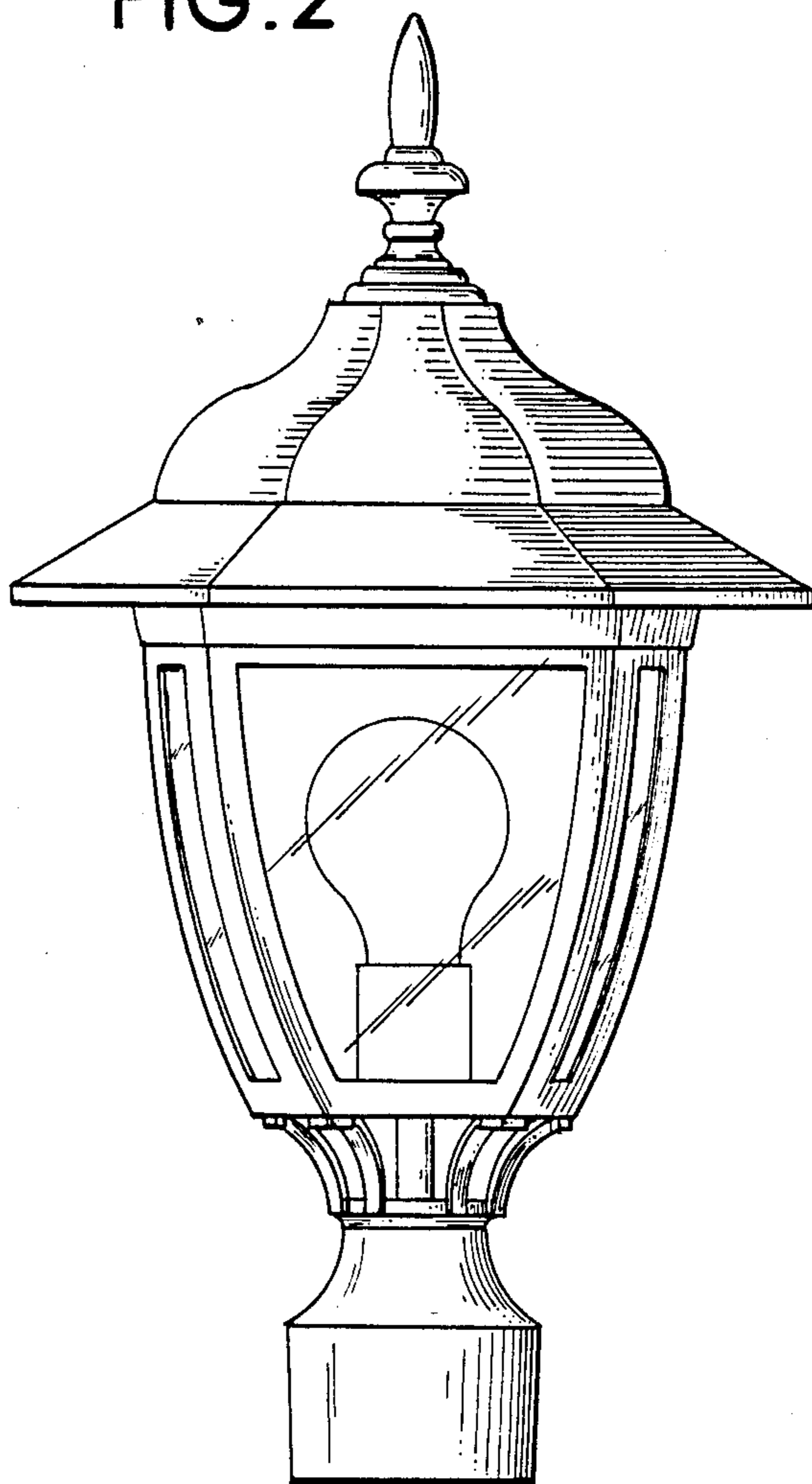

FIG.3

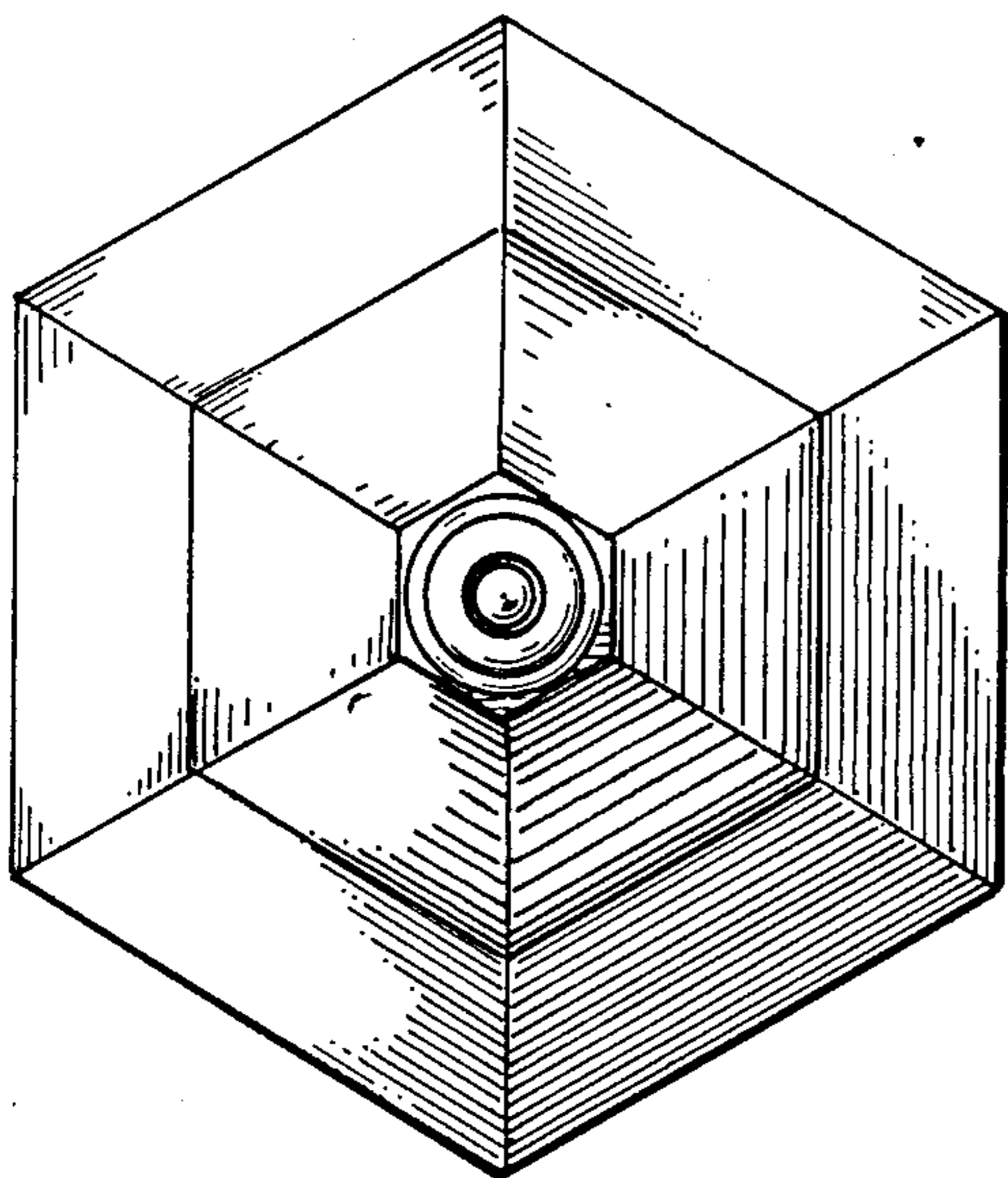

FIG.4

