

[54] AUTOMOBILE

[75] Inventors: Yukio Kurosu; Shigeo Ueno; Toshiki Nakatsuka, all of Wako, Japan

[73] Assignee: Honda Giken Kogyo Kabushiki Kaisha, Japan

[\*\*] Term: 14 Years

[21] Appl. No.: 922,557

[22] Filed: Oct. 23, 1986

[30] Foreign Application Priority Data

Aug. 26, 1986 [JP] Japan ..... 61-33228

[52] U.S. Cl. .... D12/92

[58] Field of Search ..... D12/92; 296/185

[56] References Cited

PUBLICATIONS

Motor Trend, 8/85, p. 51, Honda Accord, bottom of page.

Motor Trend, 6/85, p. 32, Honda Quint Integra, center of page.

Motor Trend, 9/84, p. 22, Rover Honda, bottom right side of page.

Road & Track, 4/84, p. 80D, Honda/Rover, bottom left side of page.

Primary Examiner—James M. Gandy  
Attorney, Agent, or Firm—Kane, Dalsimer, Sullivan, Kurucz, Levy, Eisele and Richard

[57] CLAIM

The ornamental design for an automobile, as shown and described.

DESCRIPTION

FIG. 1 is a front elevation view of an automobile showing our new design;

FIG. 2 is a right side elevation view thereof, the left side being substantially a mirror image of that shown;

FIG. 3 is a rear elevation view thereof;

FIG. 4 is a top plan view thereof; and

FIG. 5 is a perspective view thereof.

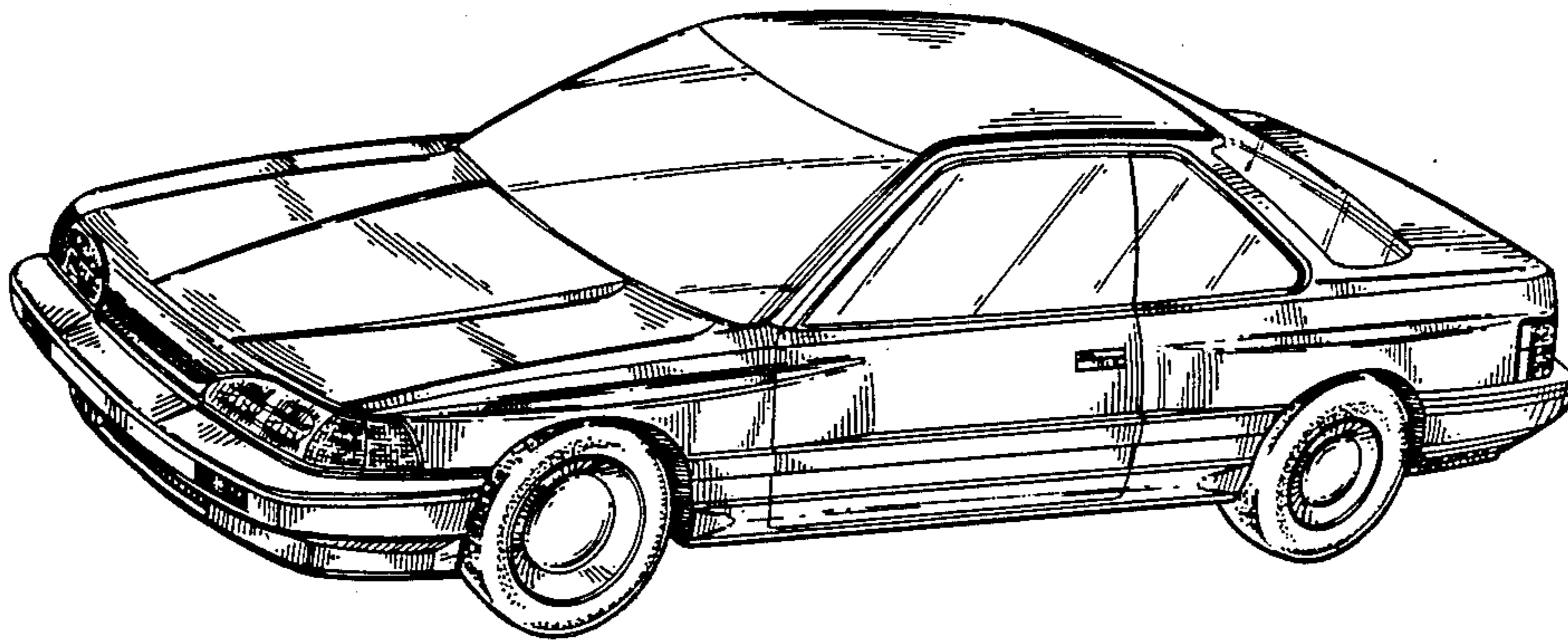

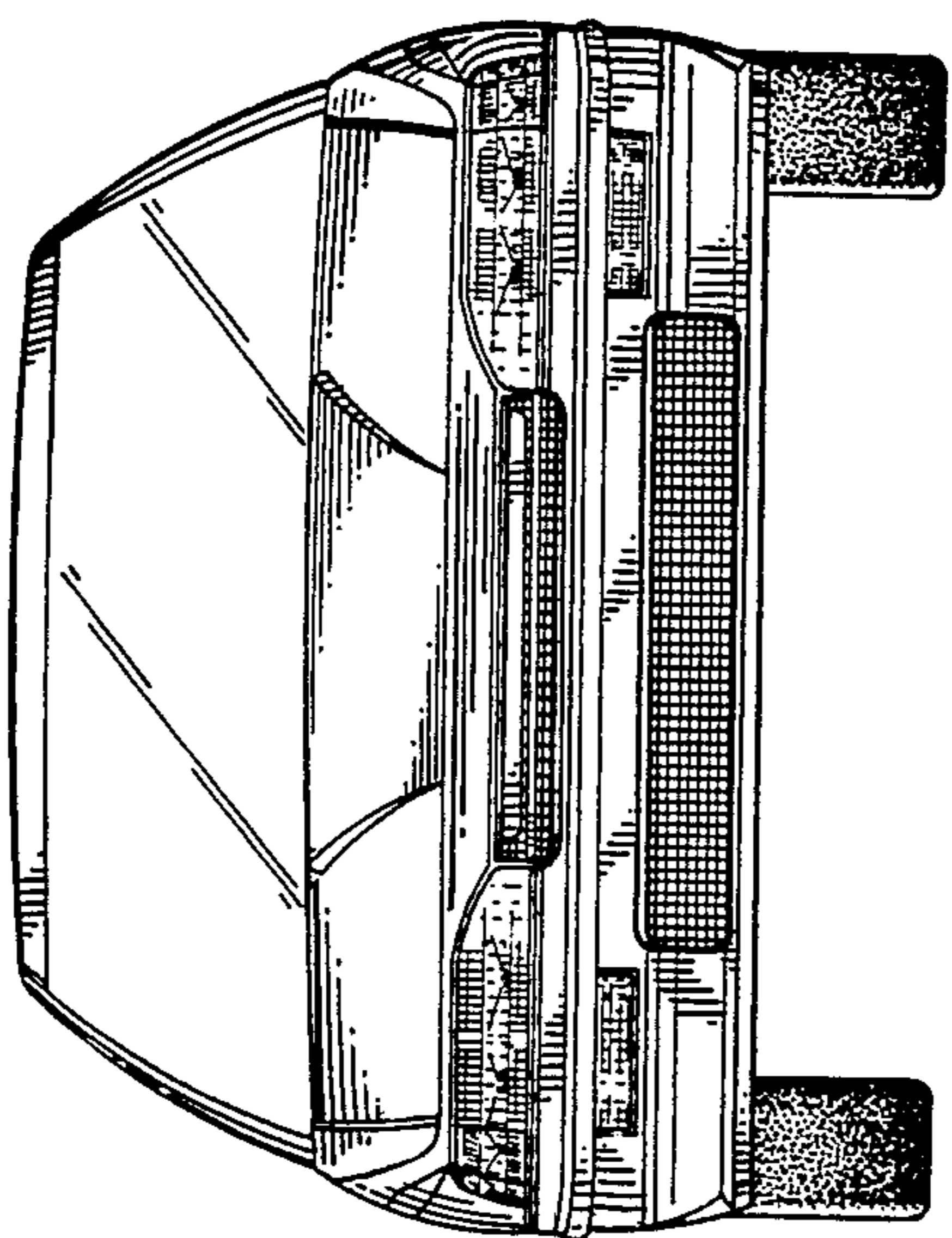

FIG. 1

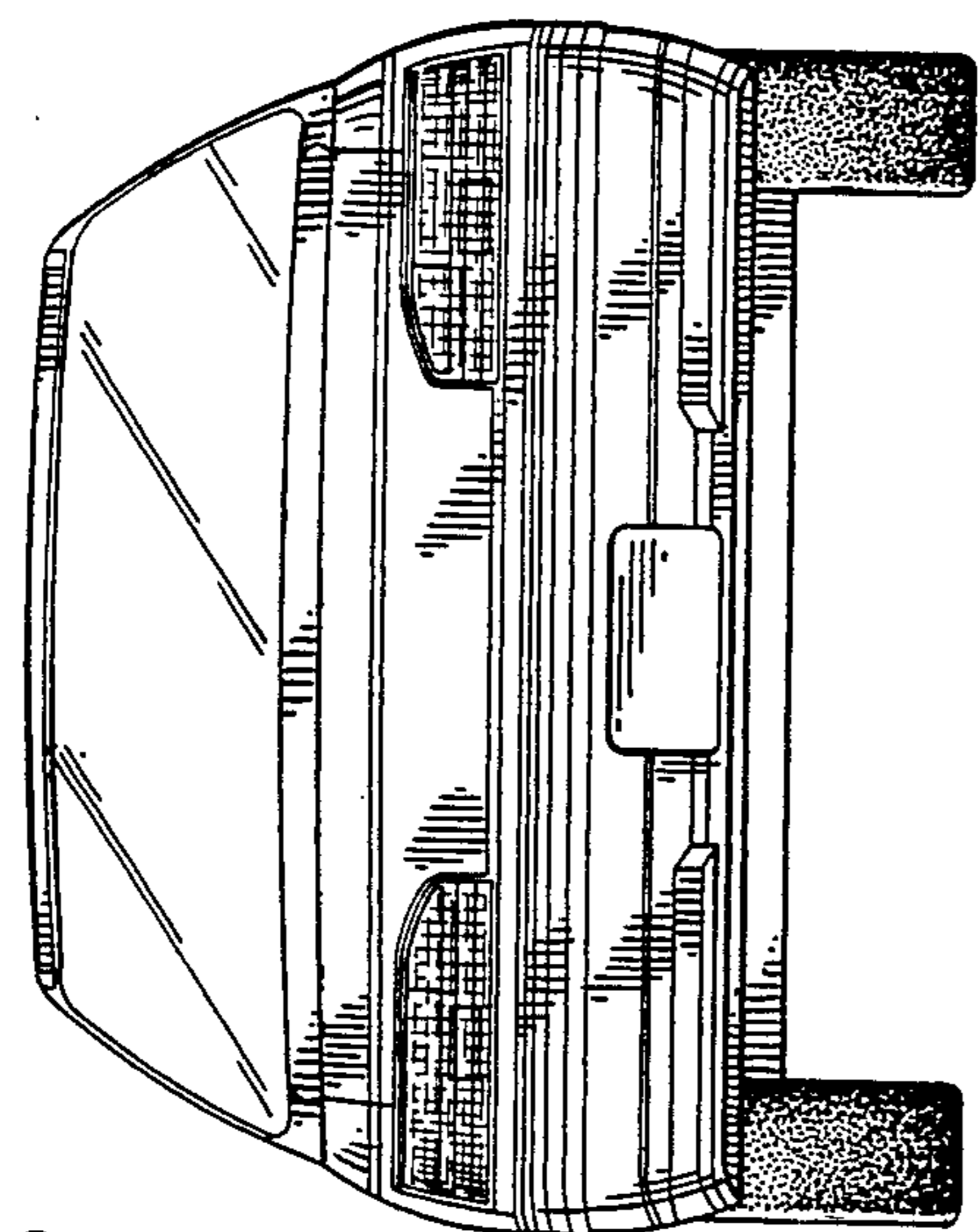

FIG. 3

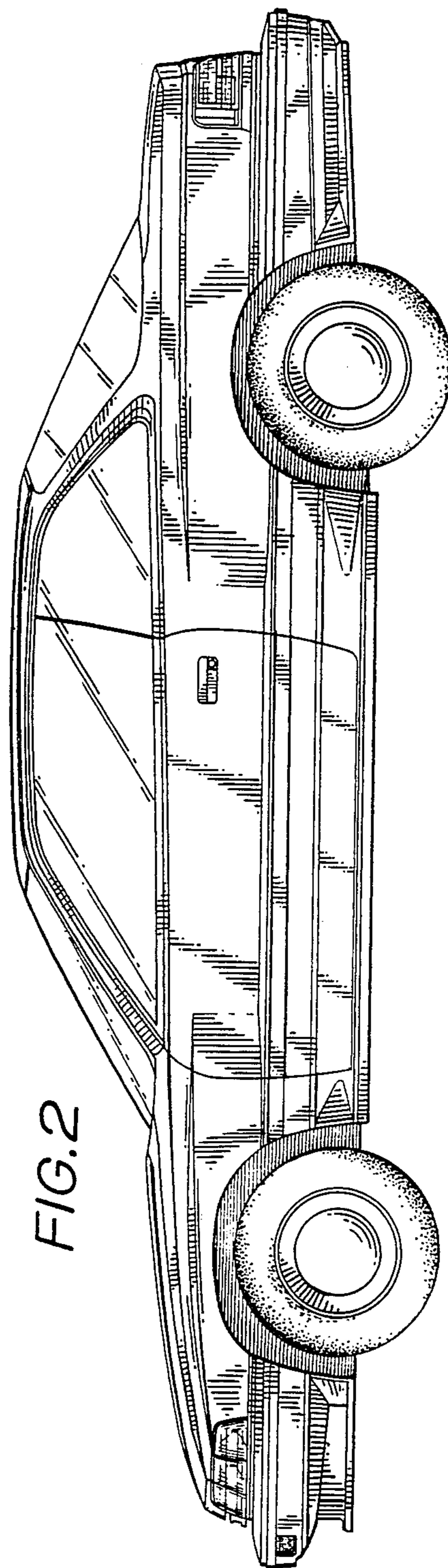

FIG. 2

FIG. 4

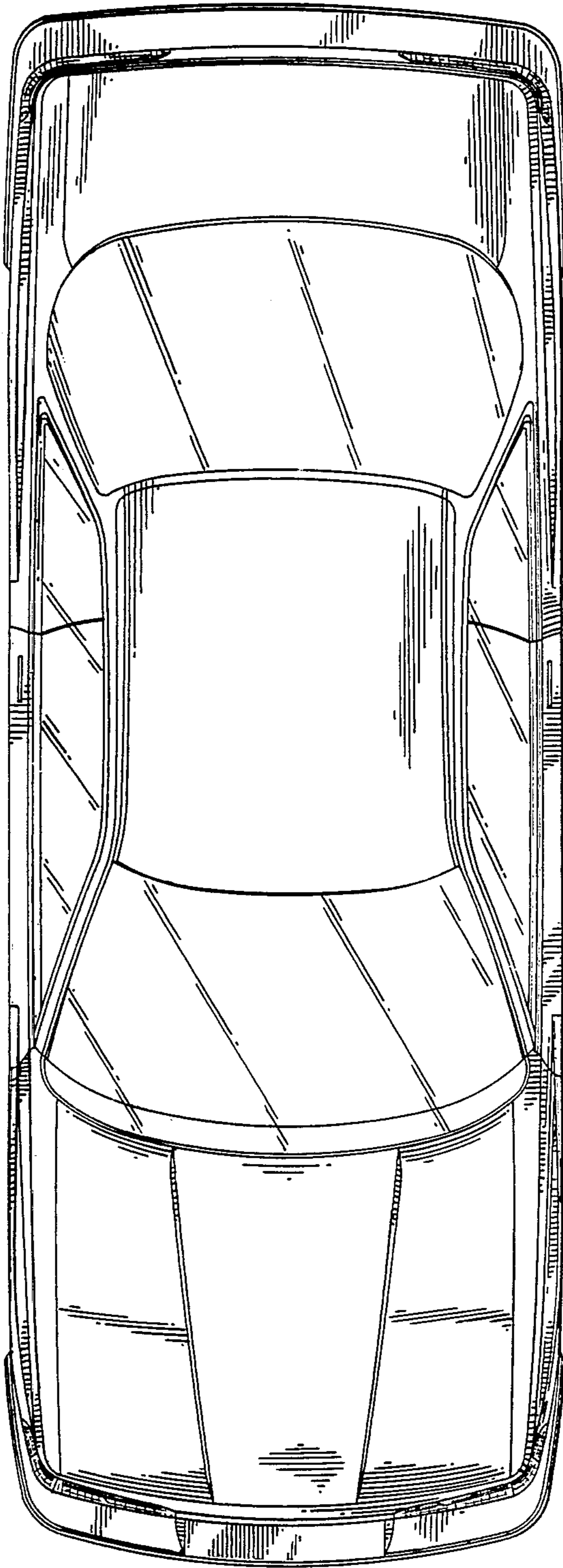

FIG. 5

