

[54] **PRECISION LATHE**

[56]

References Cited

U.S. PATENT DOCUMENTS

[75] **Inventor: Cheng-Chwen Huang, Dah-Li, Taiwan**

D. 178,431 7/1956 Siekmann et al. D15/130
D. 257,678 12/1980 Cleary et al. D15/130
3,303,731 2/1967 Zawistowski 82/2 R
3,424,040 1/1969 Vetsch 408/35
4,324,161 4/1982 Klancnik et al. 82/2 R

[73] **Assignee: Shenjey Industrial Co., Ltd., Taichung, Taiwan**

Primary Examiner—B. J. Bullock

[**] **Term: 14 Years**

[57]

CLAIM

The ornamental design for a precision lathe, as shown.

[21] **Appl. No.: 712,083**

DESCRIPTION

[22] **Filed: Mar. 15, 1985**

[52] **U.S. Cl. D15/130**

[58] **Field of Search D15/130; 27/27 R;**

82/2 R; 408/35

FIG. 1 is a front view of the precision lathe showing my new design;

FIG. 2 is a top view thereof;

FIG. 3 is a left side view thereof;

FIG. 4 is a back view thereof; and

FIG. 5 is a right side view thereof.

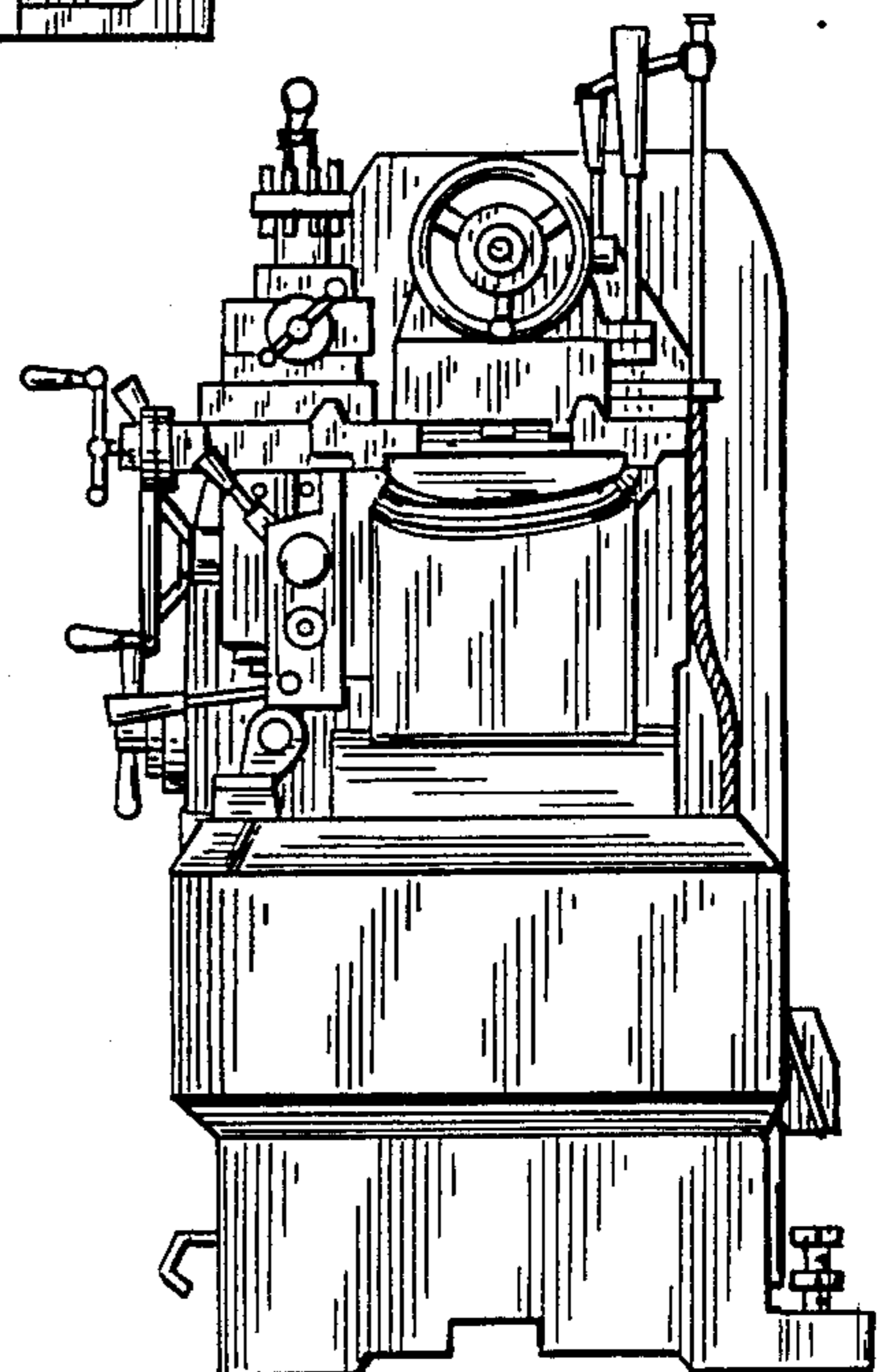
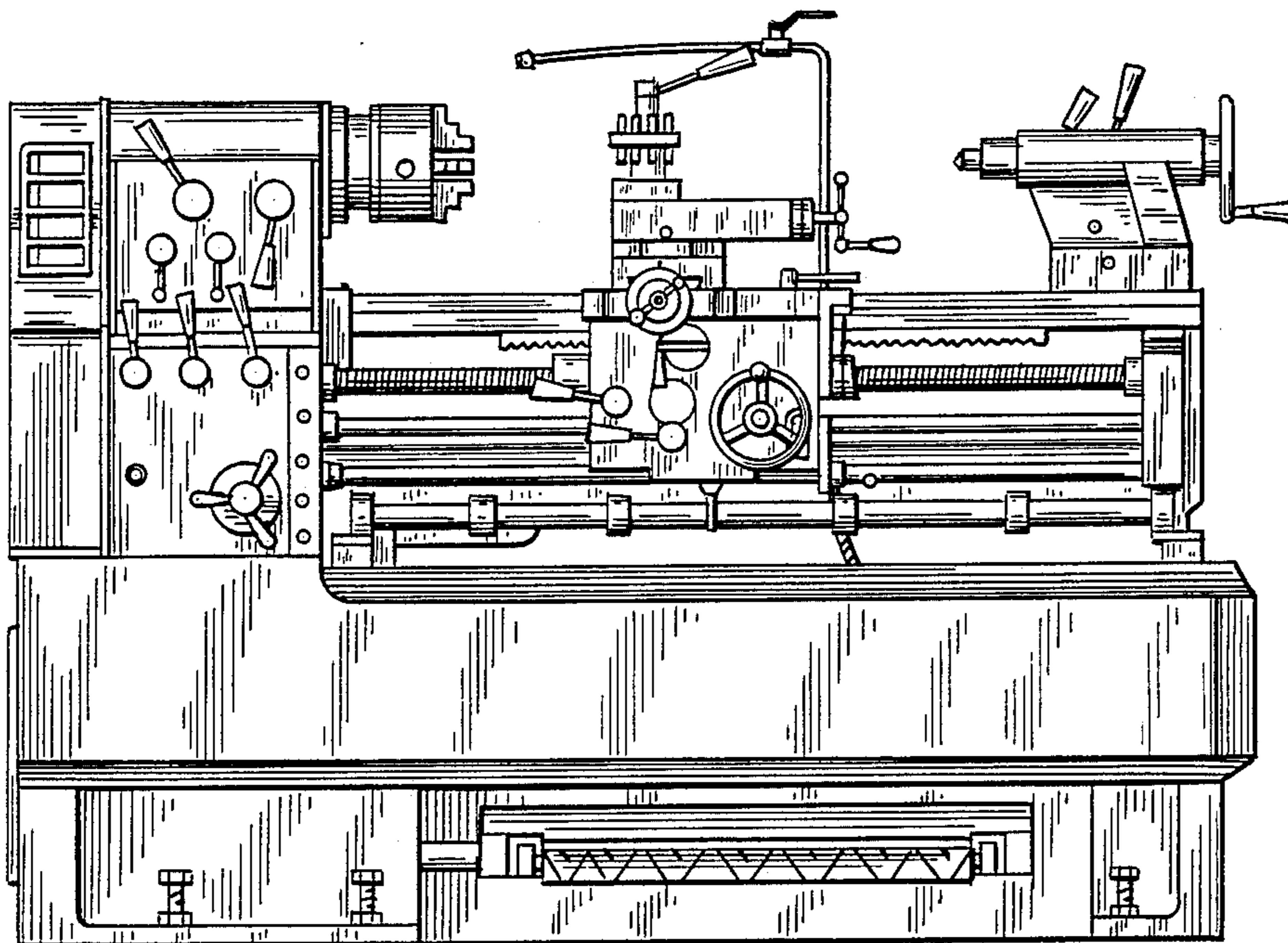

Fig. 1

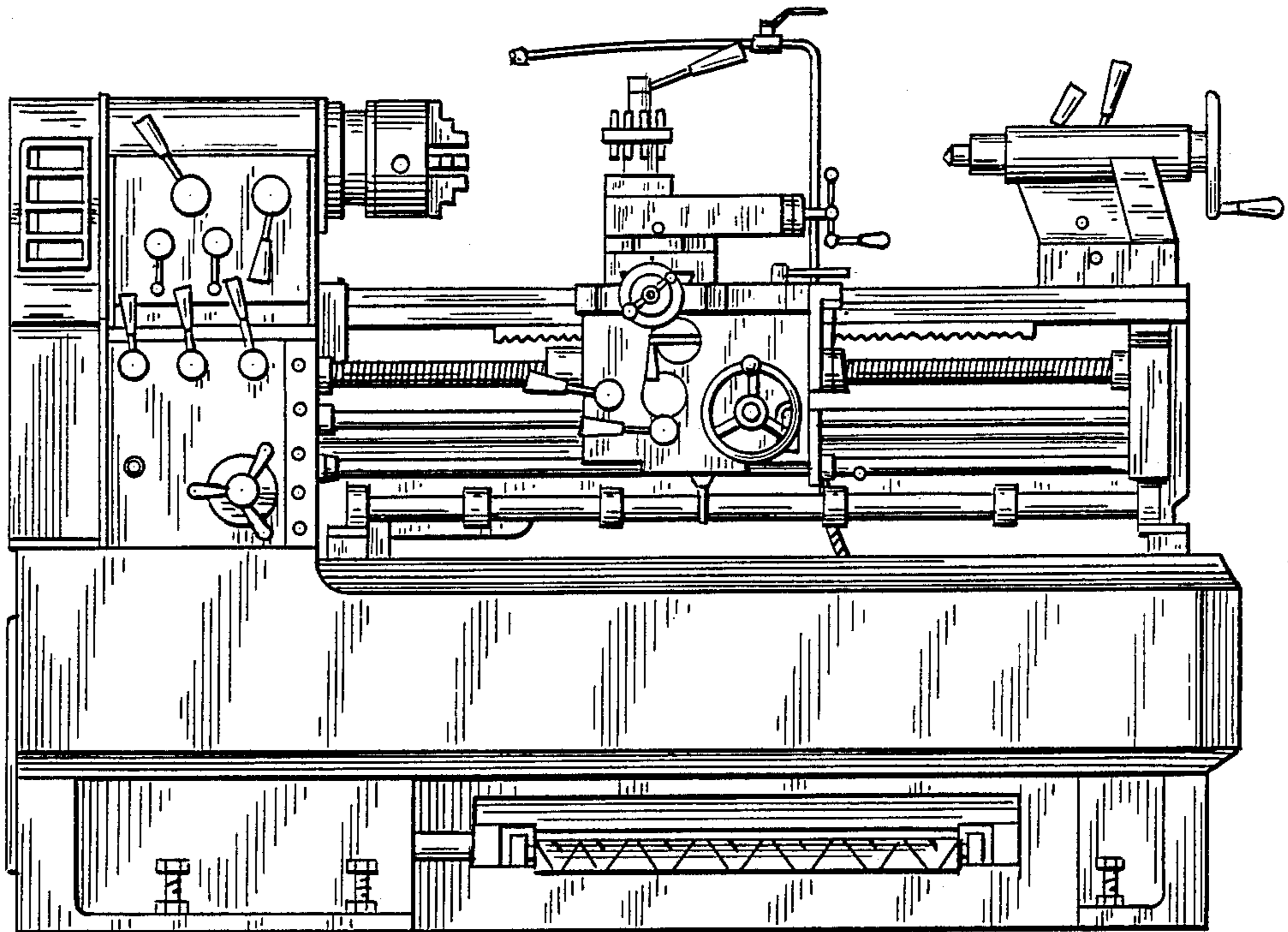

Fig. 2

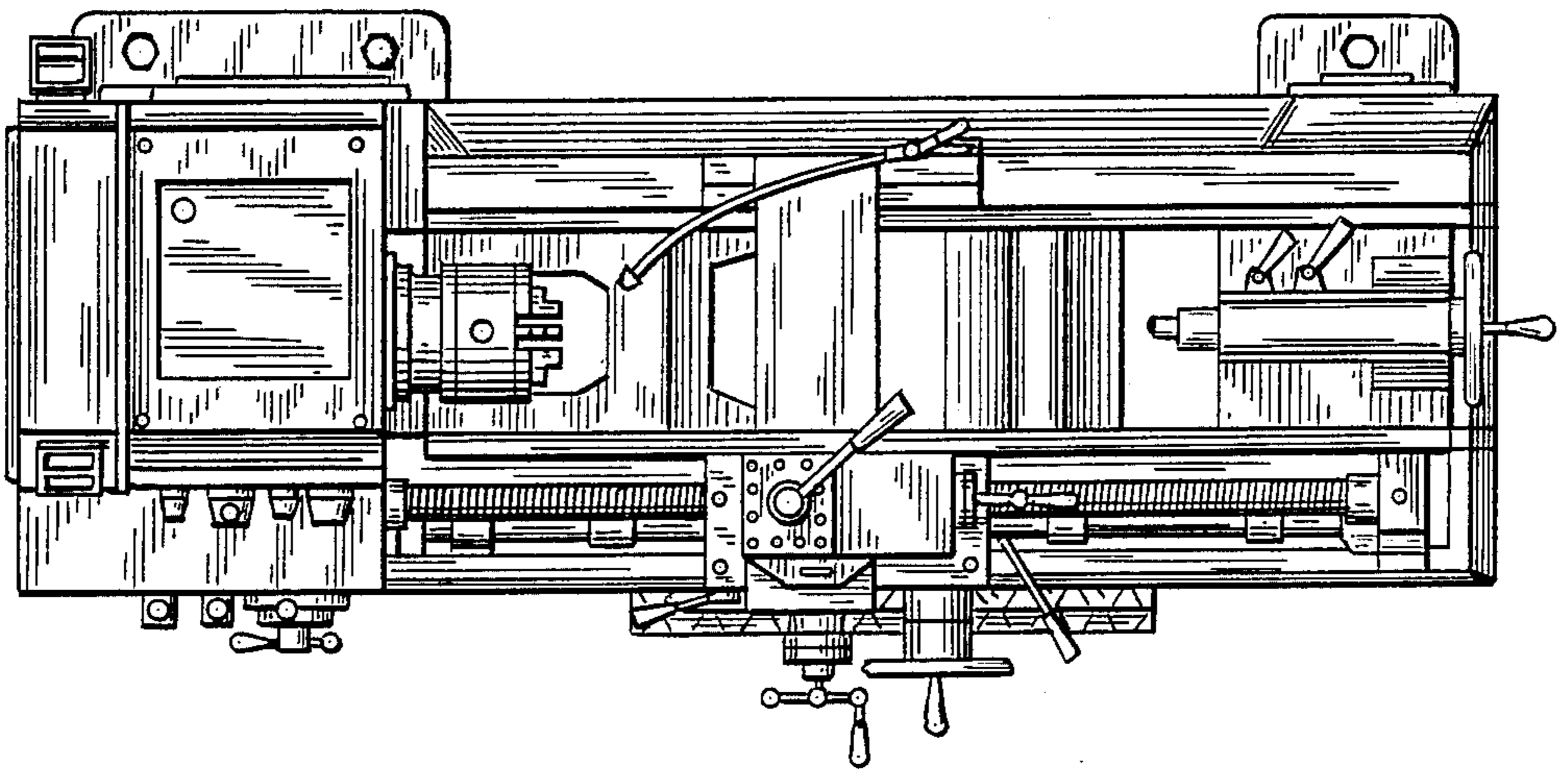

Fig. 3

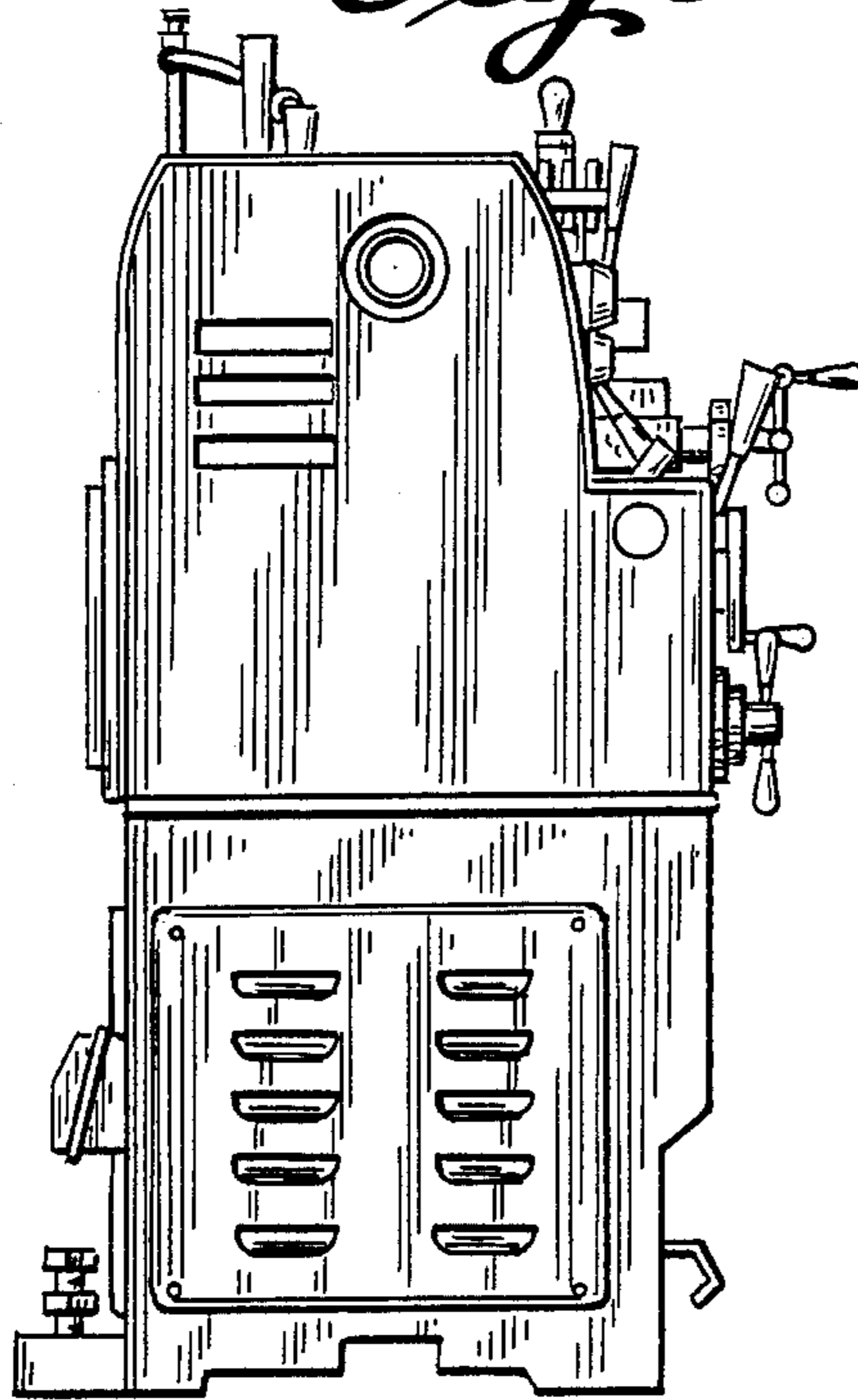

Fig. 5

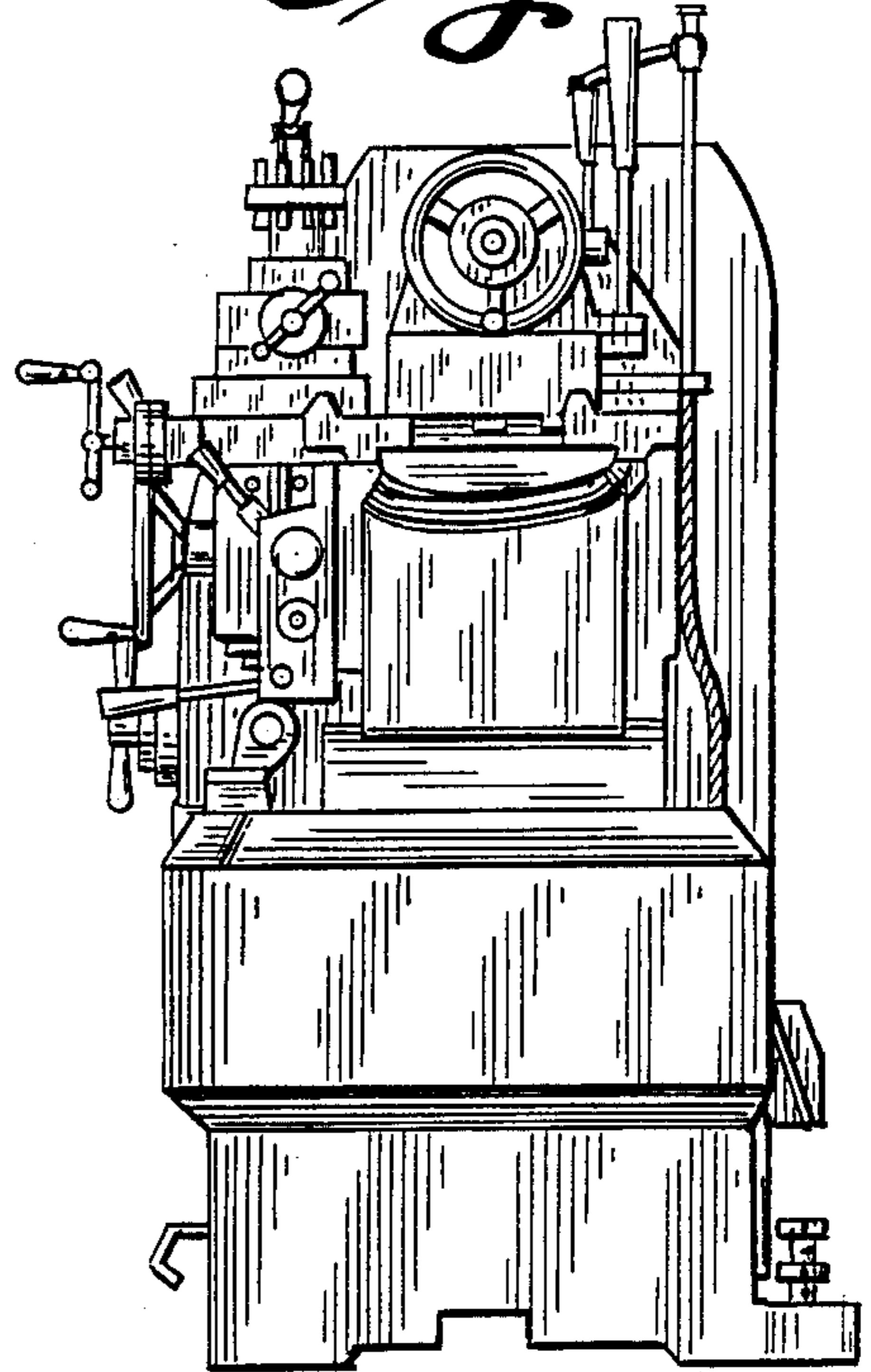

Fig. 4

