

[54] RAIL CAR

D. 235,750 7/1975 Edwards ..... D12/40  
D. 256,006 7/1980 Cuccio et al. .... D12/40  
4,469,369 9/1984 Belik et al. .... 105/329.1

[75] Inventors: Michael Groves; Anthony Hume;  
Jonathan Sothcott, all of Warwick,  
England; Martin Pemberton,  
Sydney, Australia

OTHER PUBLICATIONS

Popular Science, Jan. 1976, p. 61, Boeing Rail Vehicle,  
(top).

[73] Assignee: State Rail Authority of New South  
Wales, Australia

Primary Examiner—Wallace R. Burke  
Assistant Examiner—Kay H. Chin  
Attorney, Agent, or Firm—Stevens, Davis, Miller &  
Mosher

[\*\*] Term: 14 Years

[21] Appl. No.: 857,604

[57] CLAIM

[22] Filed: Apr. 24, 1986

The ornamental design for a rail car, as shown and  
described.

[30] Foreign Application Priority Data

DESCRIPTION

Oct. 25, 1985 [AU] Australia ..... 3067/85

[52] U.S. Cl. .... D12/40

[58] Field of Search ..... D12/36, 38, 39, 40;  
105/329.1

FIG. 1 is a front perspective view of a rail car showing  
our new design;

FIG. 2 is a front elevational view thereof on a reduced  
scale;

FIG. 3 is a right side elevational view thereof, the left  
side elevational view being a mirror image of that  
shown;

FIG. 4 is a top plan view thereof; and,

FIG. 5 is a rear elevational view thereof on a reduced  
scale.

[56] References Cited

U.S. PATENT DOCUMENTS

D. 197,033 12/1963 Lich ..... D12/40  
D. 198,551 6/1964 Gardner ..... D12/40  
D. 199,421 10/1964 Sundberg ..... D12/40  
D. 201,226 5/1965 Schmidt ..... D12/40

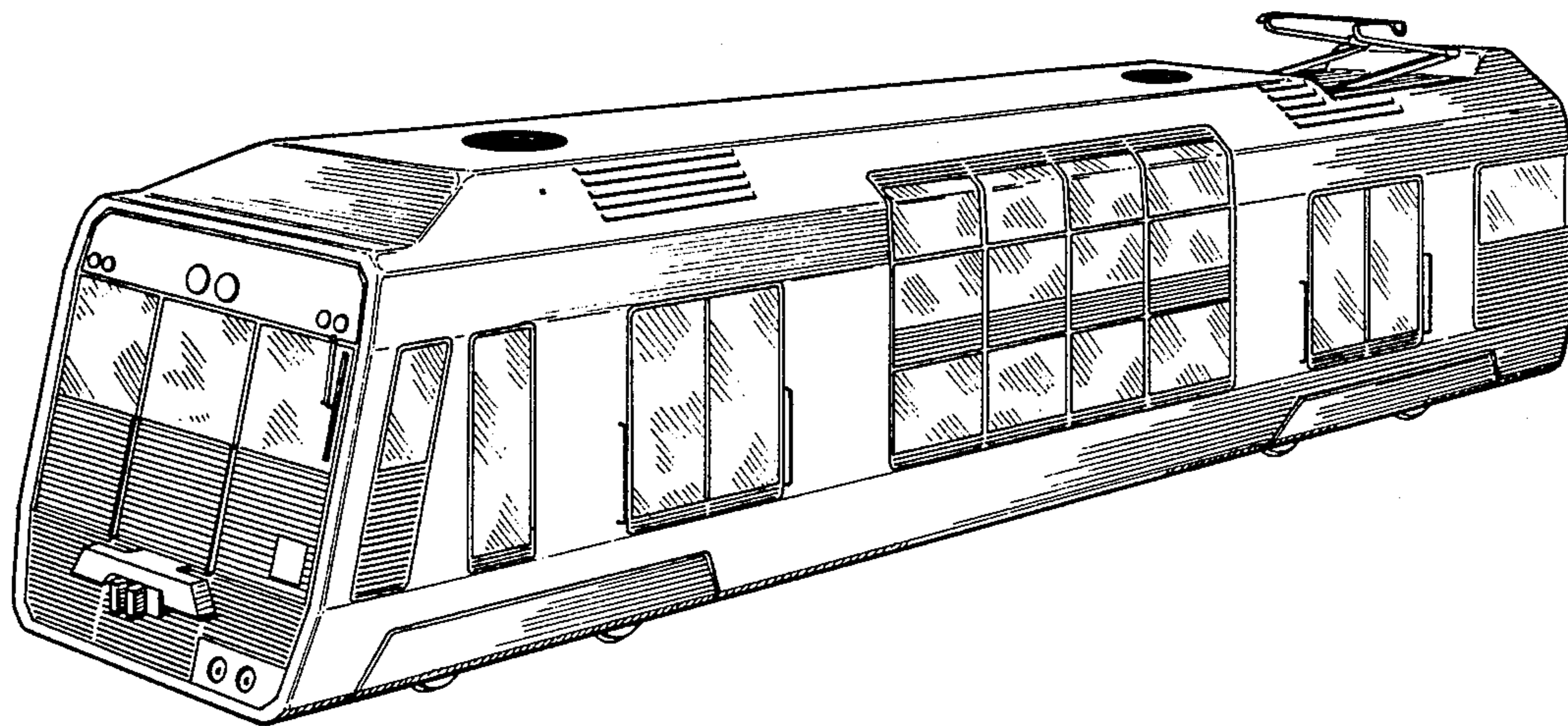

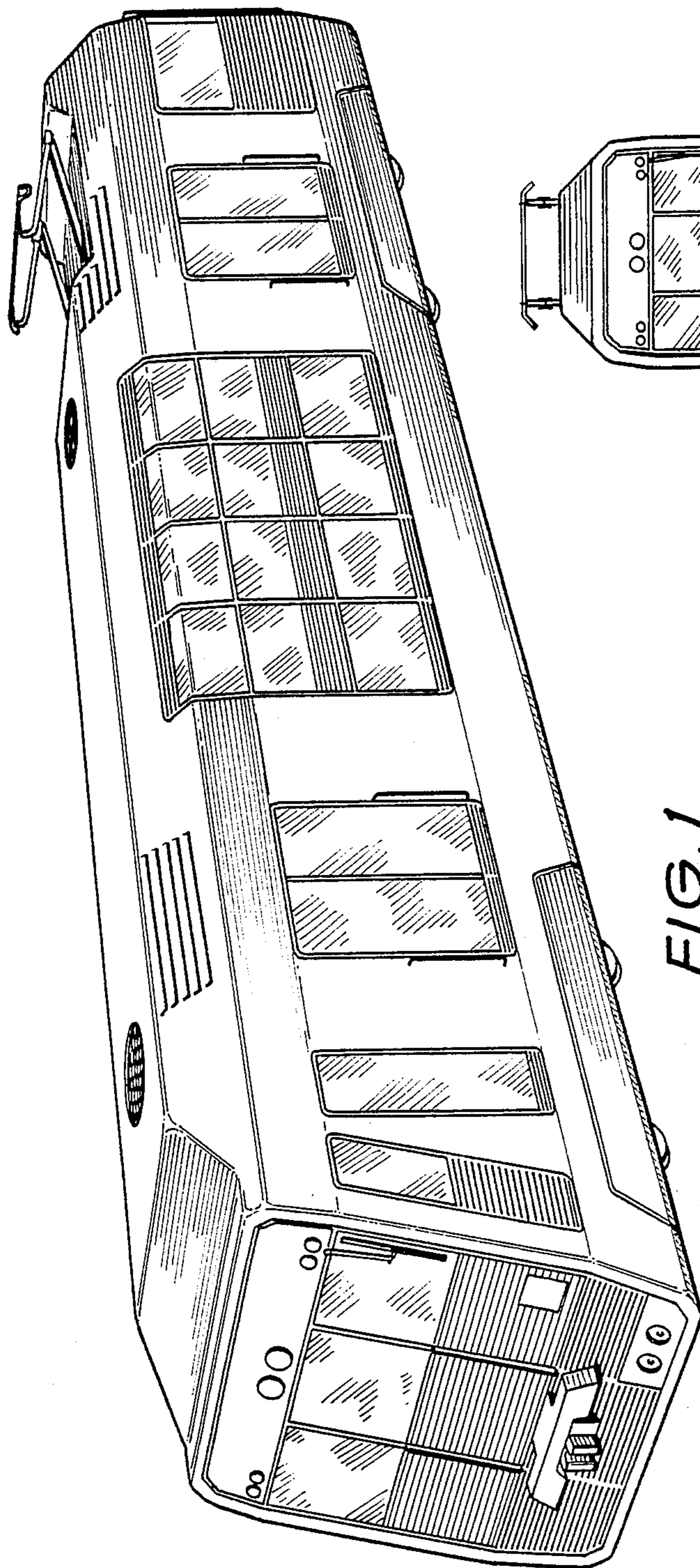

FIG. 1

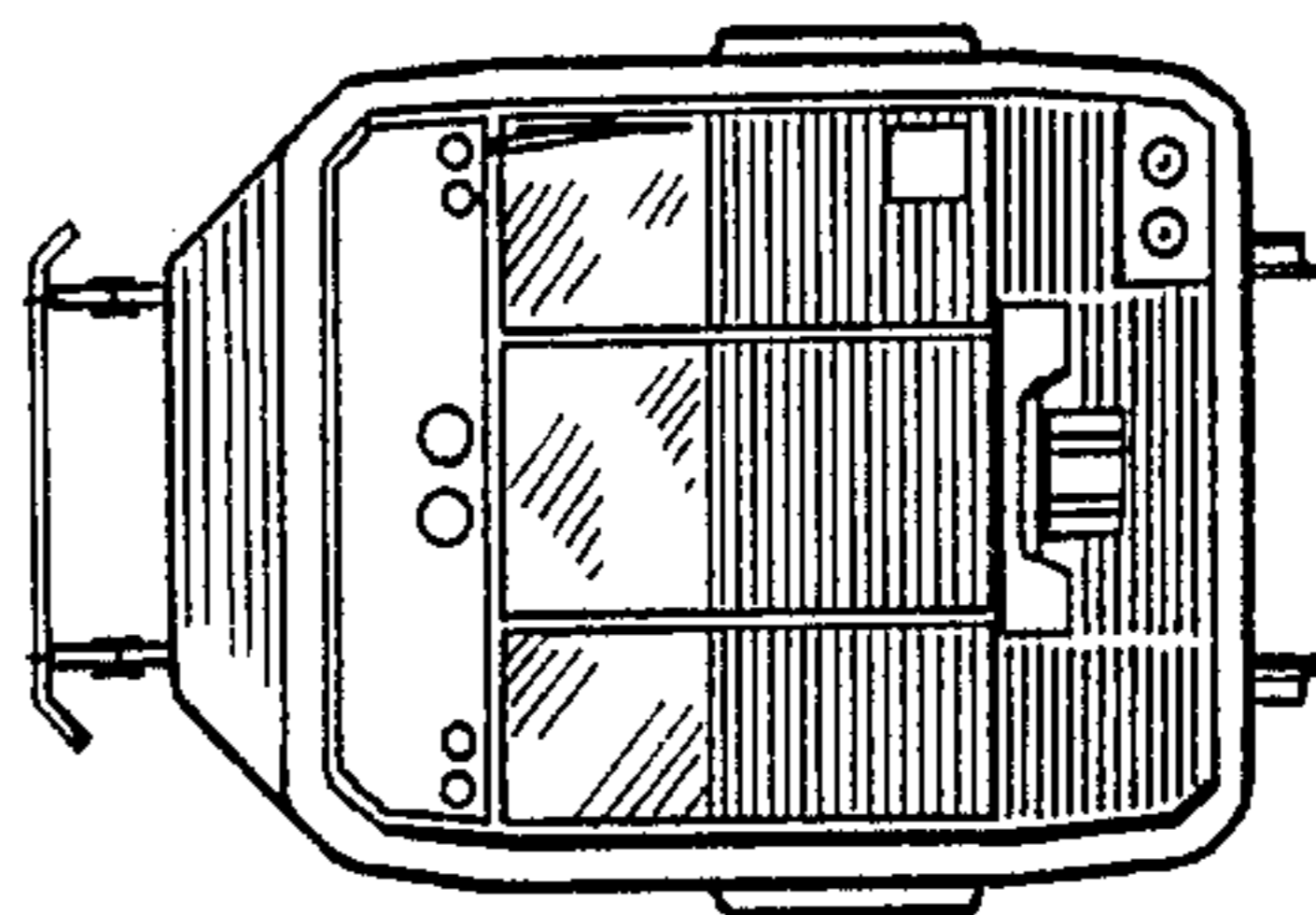

FIG. 2

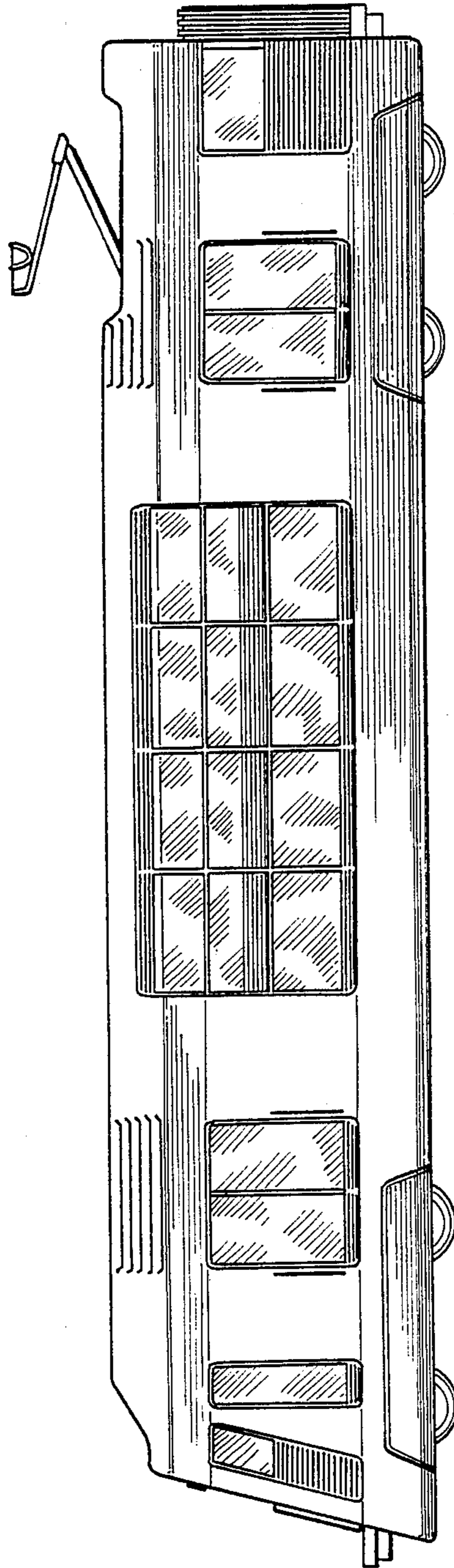

FIG. 3

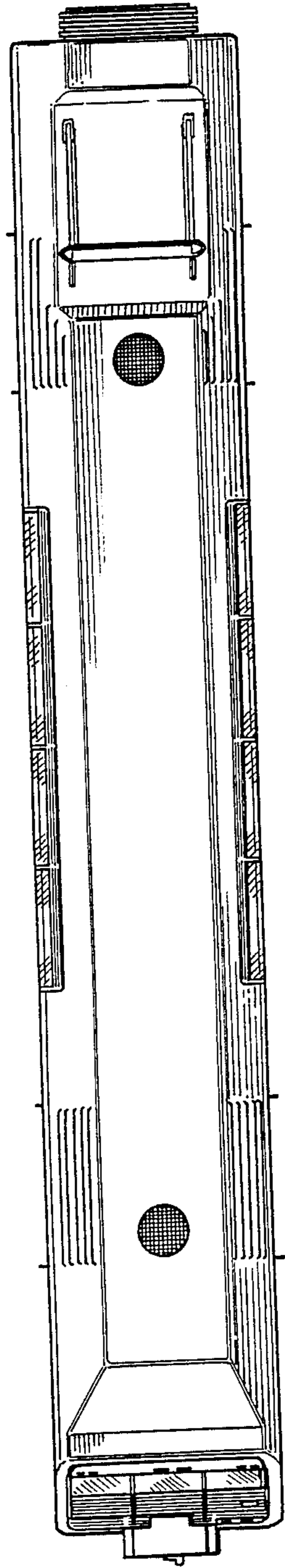

FIG. 4

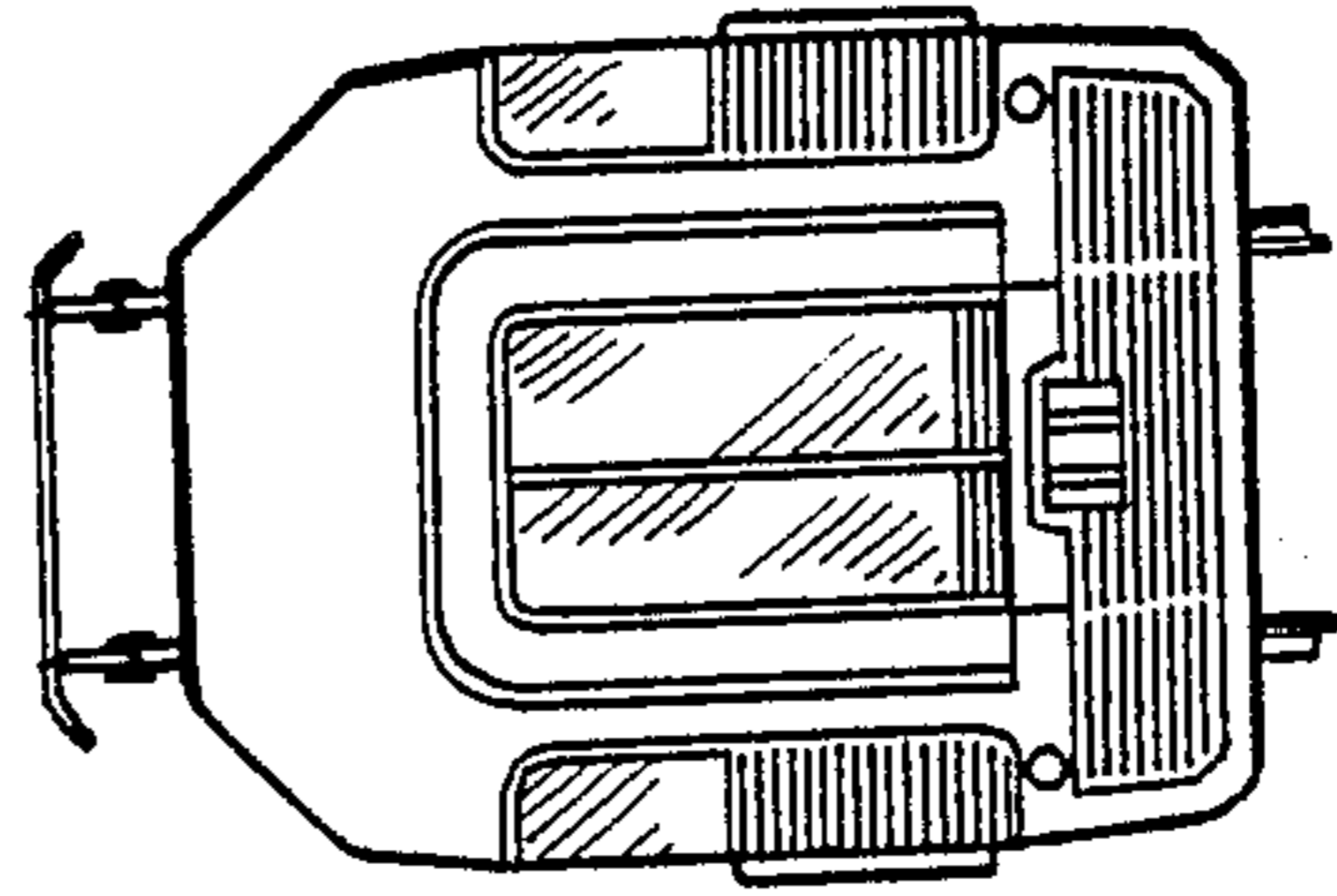

FIG. 5