

[54] TIE RACK

[75] Inventor: Lawrence F. Trafford, London, Canada

[73] Assignee: Elgin Local Employment Assistance and Development Corporation, St. Thomas, Canada

[\*\*] Term: 14 Years

[21] Appl. No.: 873,224

[22] Filed: Jun. 11, 1986

[52] U.S. Cl. .... D6/324

[58] Field of Search ..... D6/313, 320, 324, 327, D6/553, 569, 572; 211/1.3, 87, 96, 99, 100, 168, 170, 171

[56] References Cited

U.S. PATENT DOCUMENTS

- D. 135,656 5/1943 Williams ..... D6/324
- D. 149,103 3/1948 Atkins ..... D6/324

- D. 151,402 10/1948 Ragland ..... D6/324
- 2,562,622 7/1951 Laughlin ..... 211/100

Primary Examiner—B. J. Bullock  
Assistant Examiner—Dominic Simone  
Attorney, Agent, or Firm—Robert F. Delbridge; Arne I. Fors

[57] CLAIM

The ornamental design for a tie rack, as shown and described.

DESCRIPTION

FIG. 1 is a perspective view of the tie rack showing my new design, with the arm in a horizontal position;  
FIG. 2 is a top view;  
FIG. 3 is a right side view, the left side being a mirror image;  
FIG. 4 is a bottom view;  
FIG. 5 is a front view, the rear being unornamented;  
FIG. 6 is an enlarged perspective view, with the arm in a vertical position.

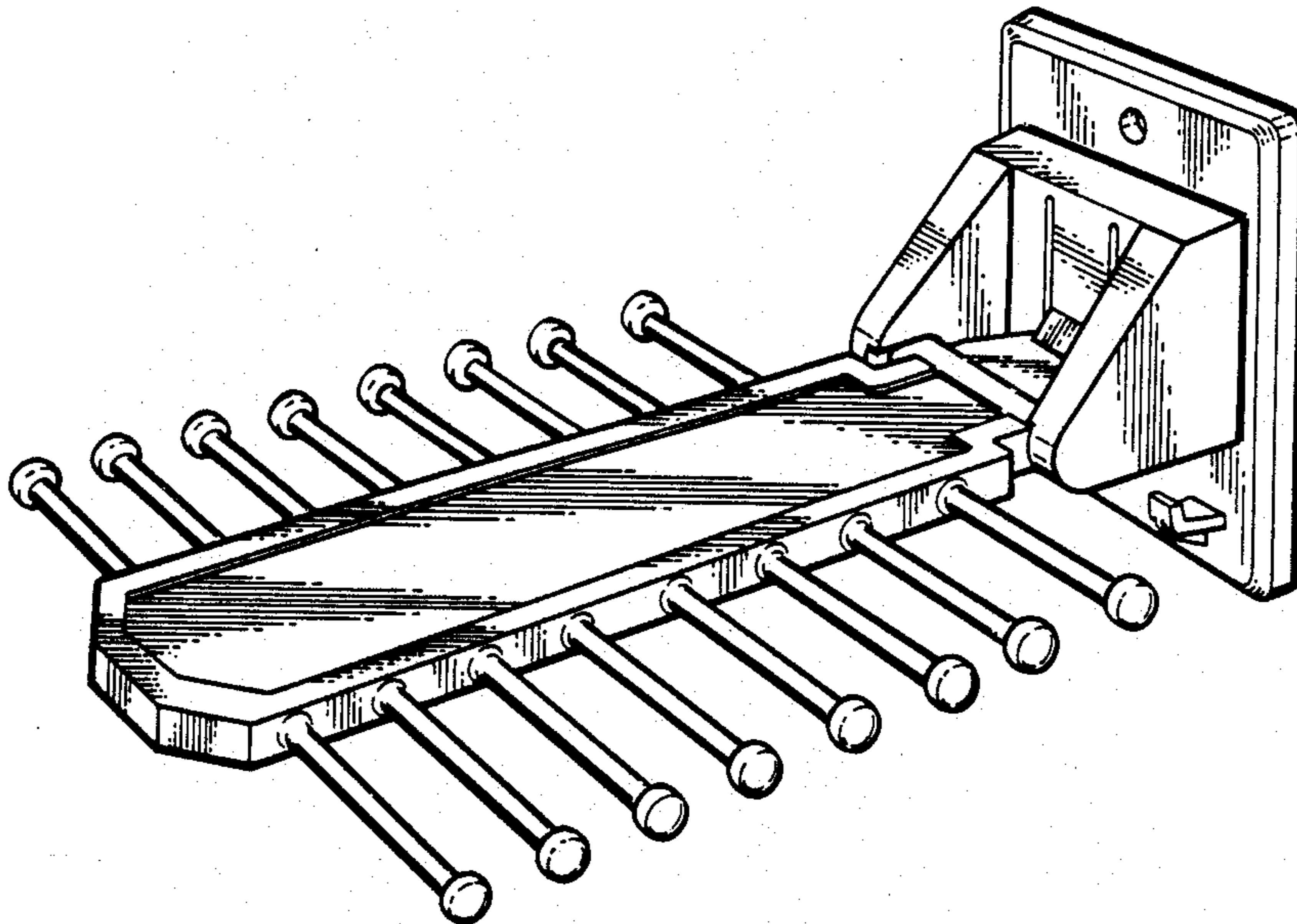

FIG. 1.

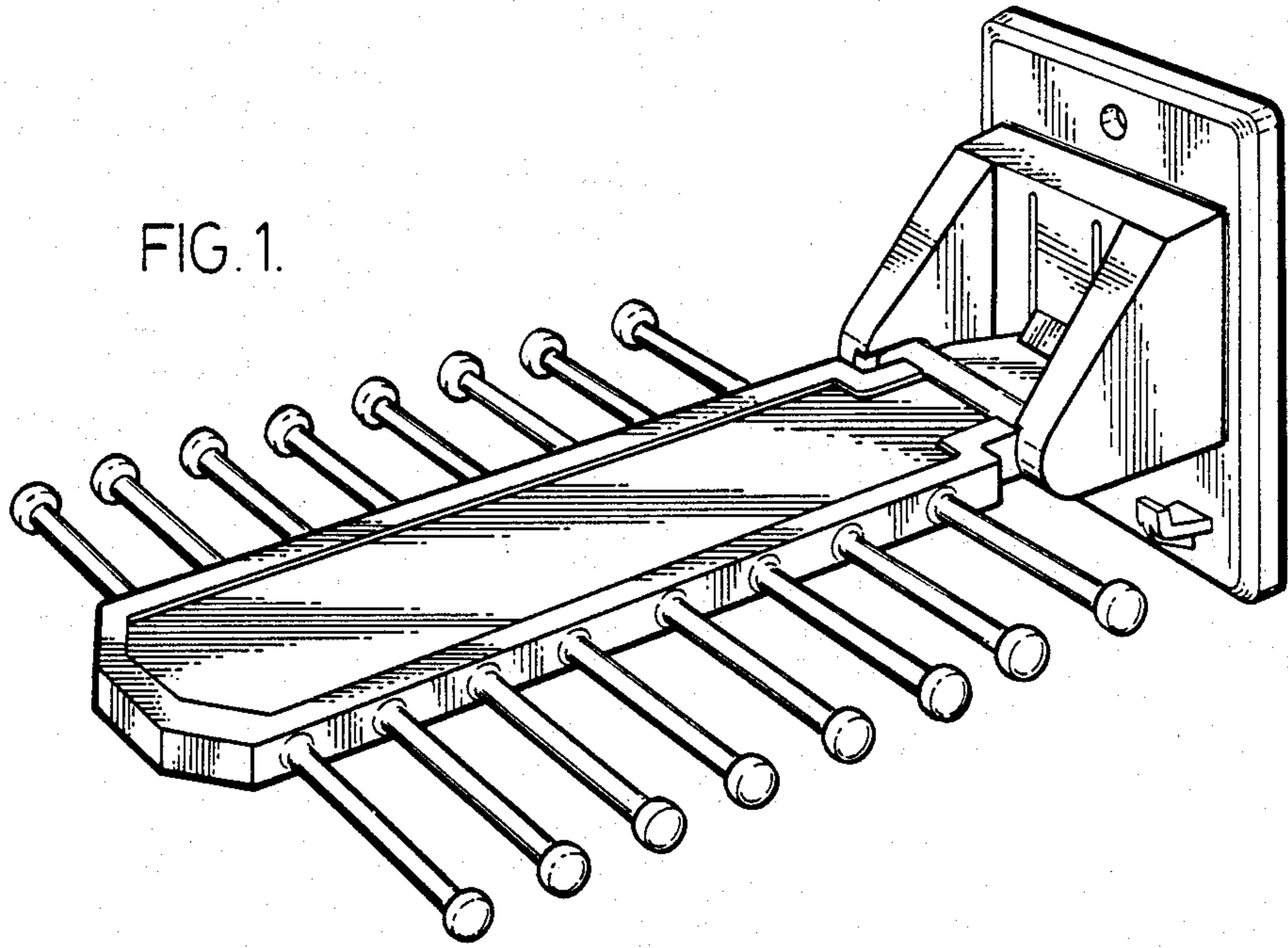

FIG. 2.

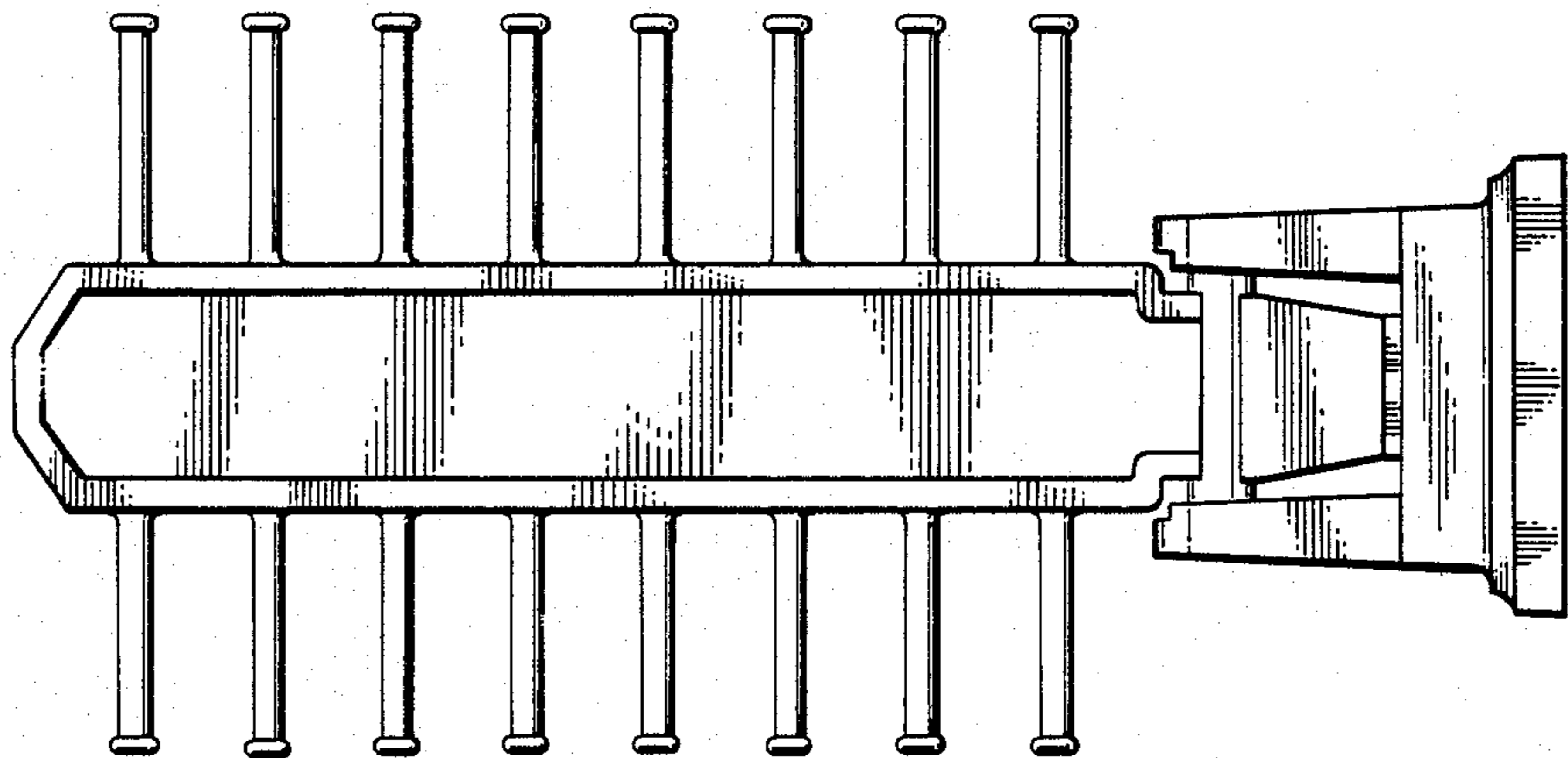

FIG. 3.

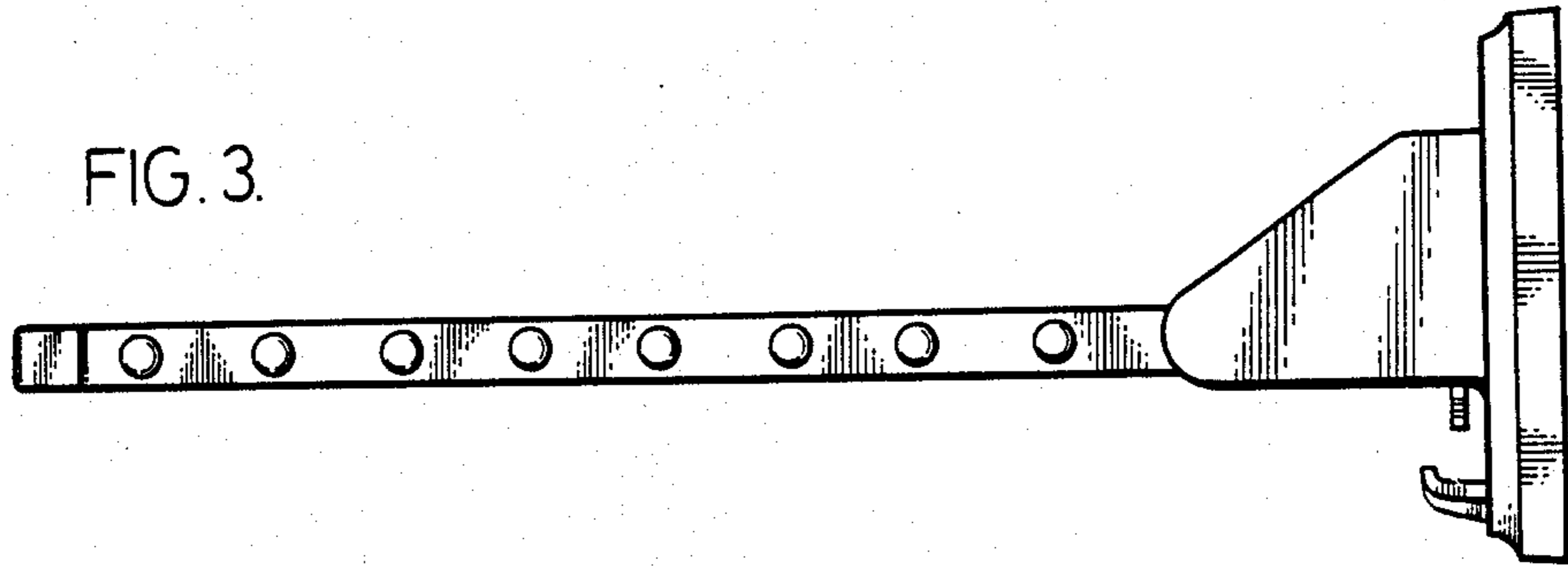

FIG. 4.

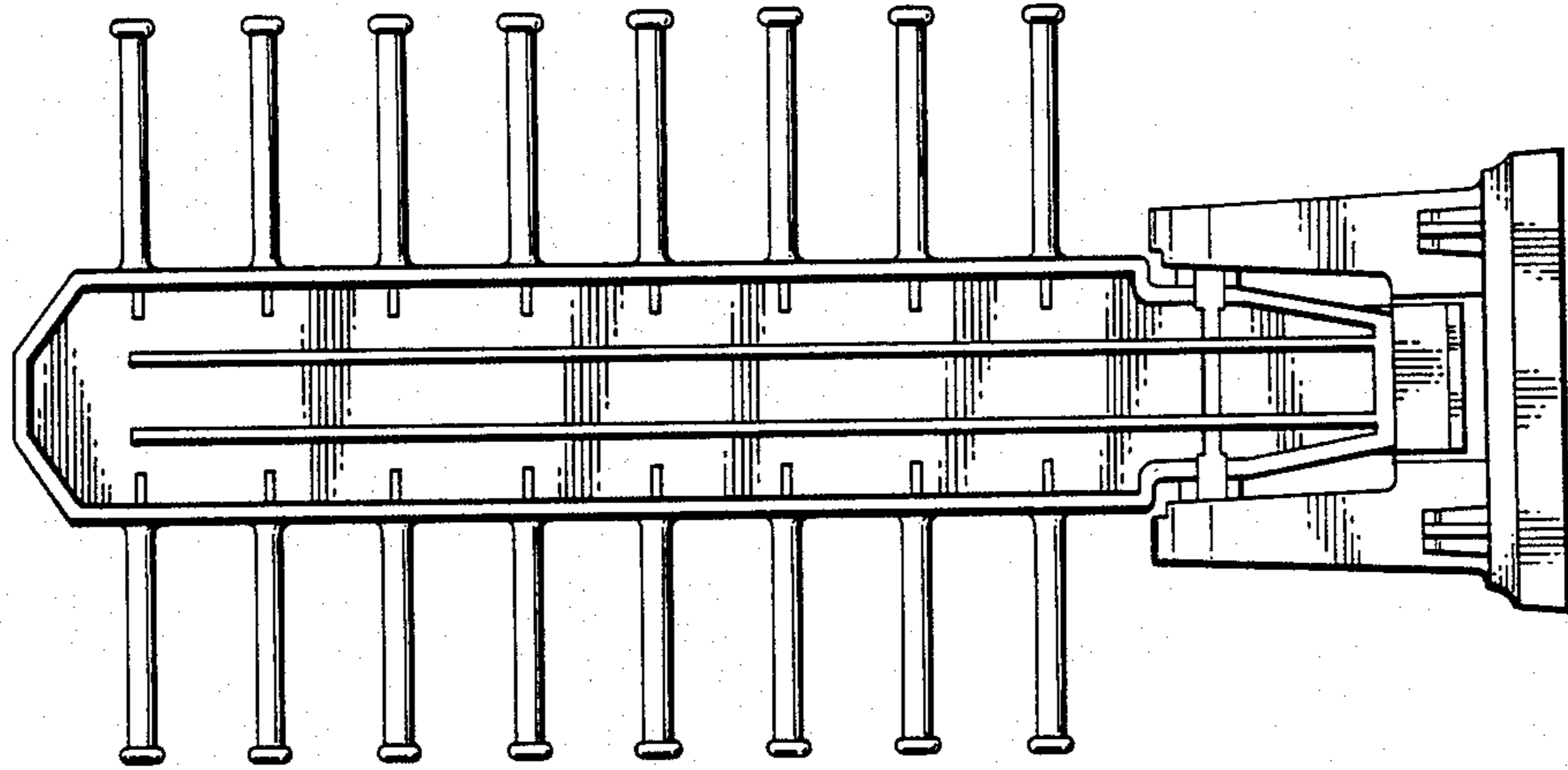

FIG. 5.

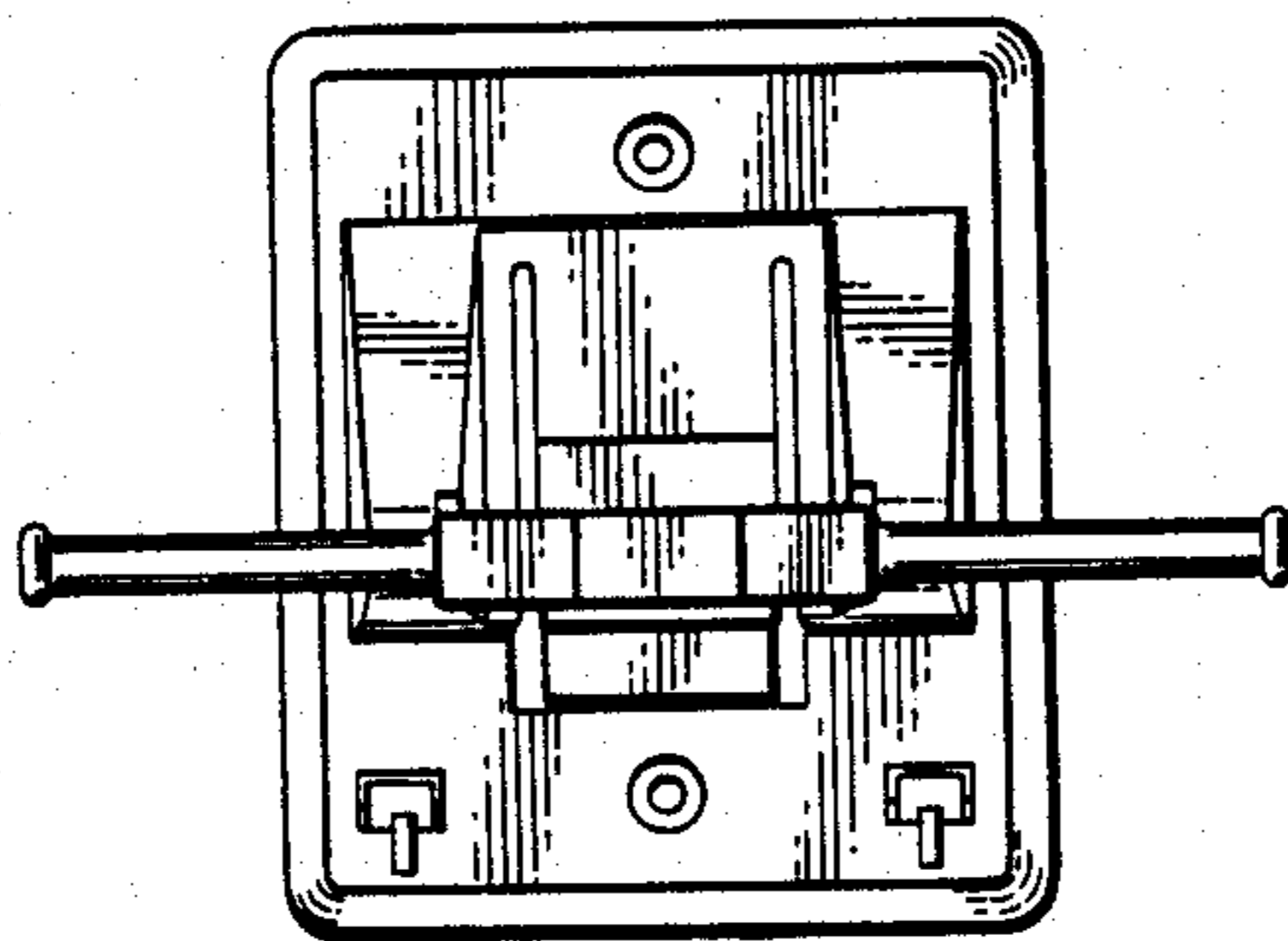

FIG. 6.

