

[54] RECONFIGURABLE TOY VEHICLE

[75] Inventor: Takashi Kunihiro, Abiko, Japan

[73] Assignee: Takara Co., Ltd., Tokyo, Japan

[\*\*] Term: 14 Years

[21] Appl. No.: 1,090

[22] Filed: Jan. 7, 1987

[30] Foreign Application Priority Data

Nov. 4, 1986 [JP] Japan ..... 61-43568

[52] U.S. Cl. .... D21/150; D21/136;  
D21/166

[58] Field of Search ..... D21/128-140,  
D21/150, 166; 446/71-78, 487; D12/82, 86, 89,  
90

[56] References Cited

U.S. PATENT DOCUMENTS

D. 218,738 9/1970 Moore et al. .... D21/137  
D. 281,001 10/1985 Ohno ..... D21/136  
D. 285,465 9/1986 Ohno ..... D21/150  
D. 285,589 9/1986 Matsushiro ..... D21/150  
D. 295,303 4/1988 Matsumoto ..... D21/136  
D. 295,305 4/1988 Yoke ..... D21/150

D. 296,914 7/1988 Matsumoto ..... D21/136

Primary Examiner—Charles A. Rademaker  
Attorney, Agent, or Firm—Price, Gess & Ubell

[57] CLAIM

The ornamental design for a reconfigurable toy vehicle,  
as shown and described.

DESCRIPTION

FIG. 1 is a front perspective view of a reconfigurable  
toy vehicle showing my new design;

FIG. 2 is a front elevational view thereof;

FIG. 3 is a right side elevational view thereof, the side  
opposite being a mirror image;

FIG. 4 is a rear elevational view thereof;

FIG. 5 is a top plan view thereof;

FIG. 6 is a bottom plan view thereof;

FIG. 7 is another front perspective view of the design  
shown in FIGS. 1 through 6 in a humanoid robot con-  
figuration;

FIG. 8 is a front elevational view thereof;

FIG. 9 is a right side elevational view thereof, the side  
opposite being a mirror image;

FIG. 10 is a rear elevational view thereof;

FIG. 11 is a top plan view thereof; and

FIG. 12 is a bottom plan view thereof.

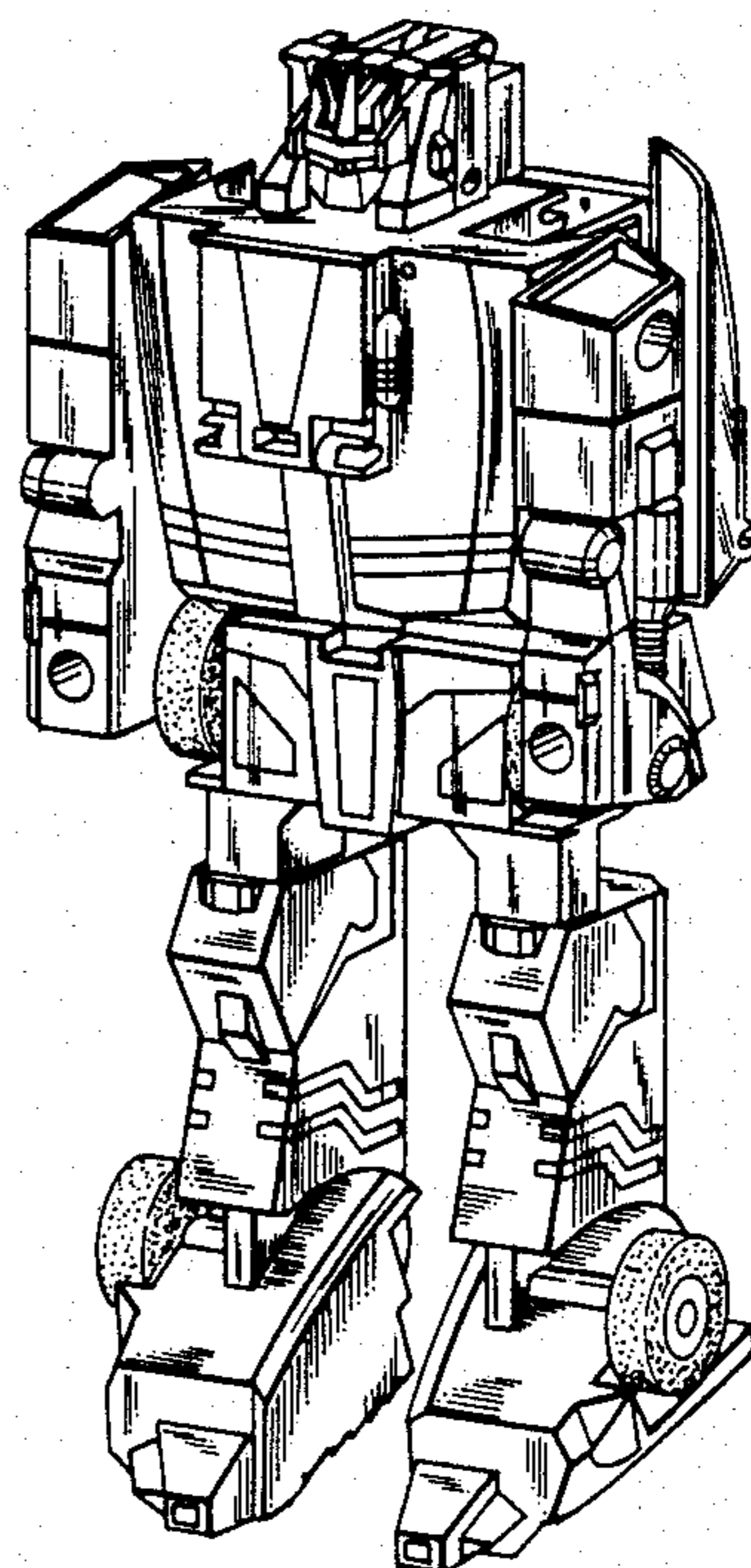
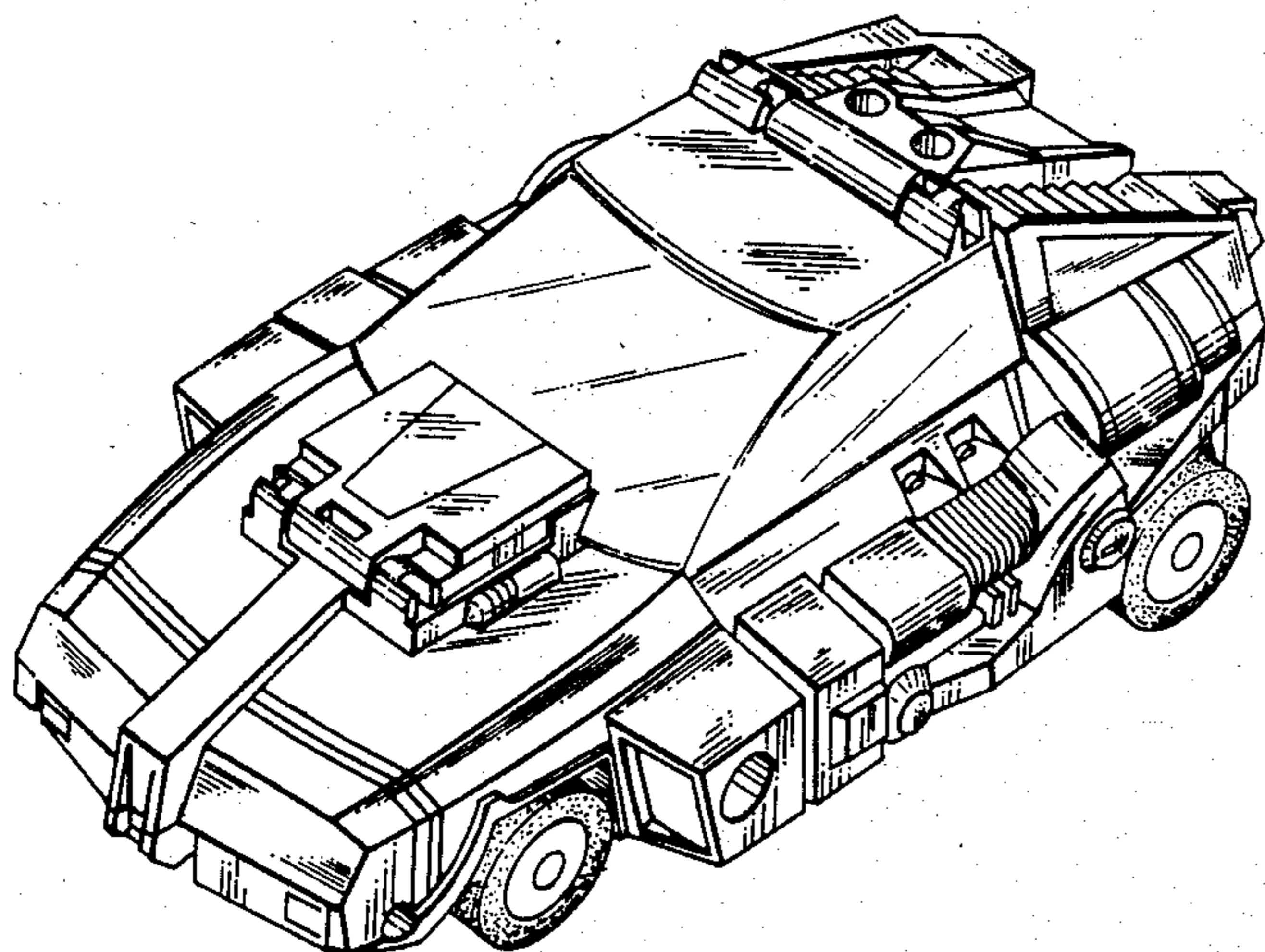

FIG. 2

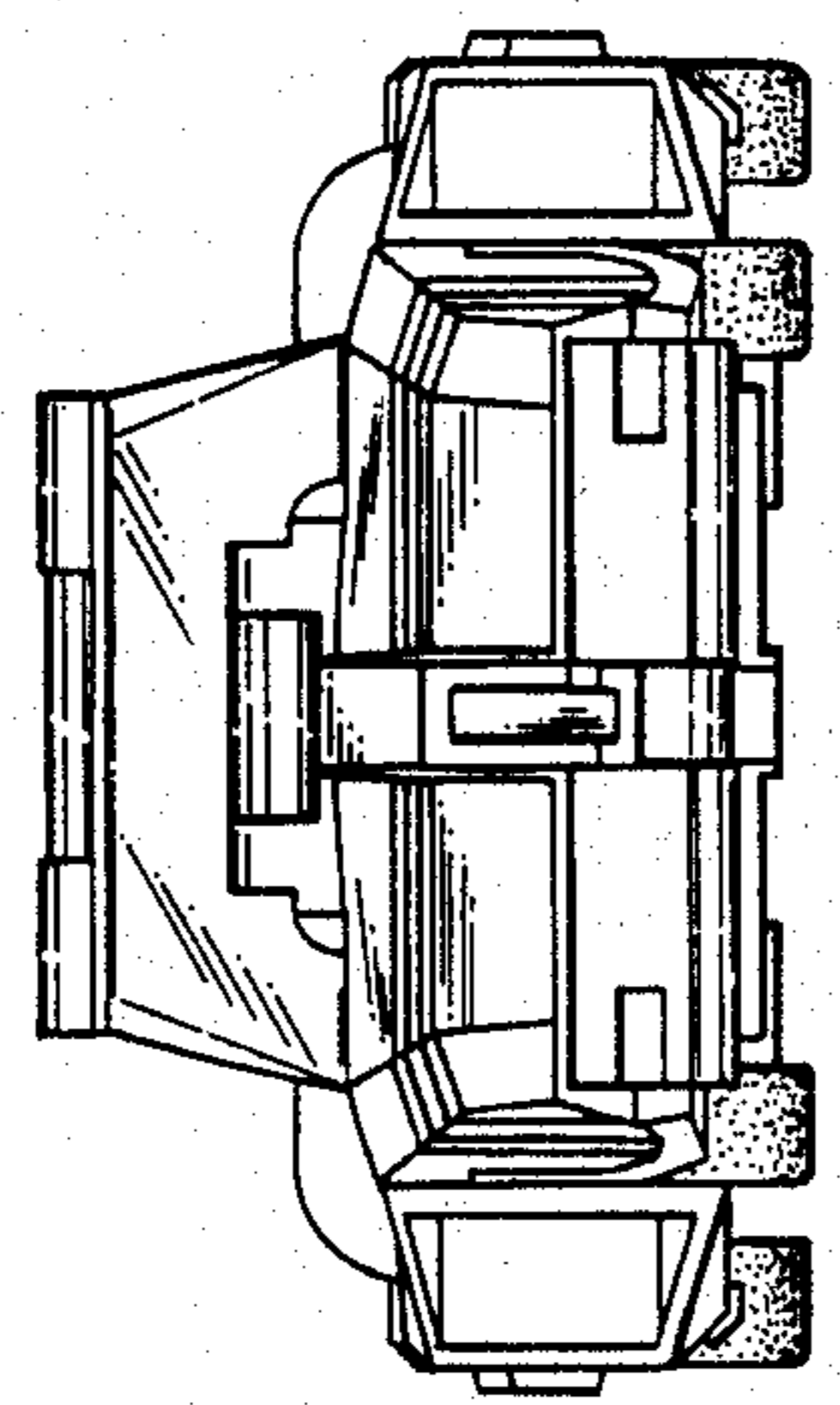

FIG. 3

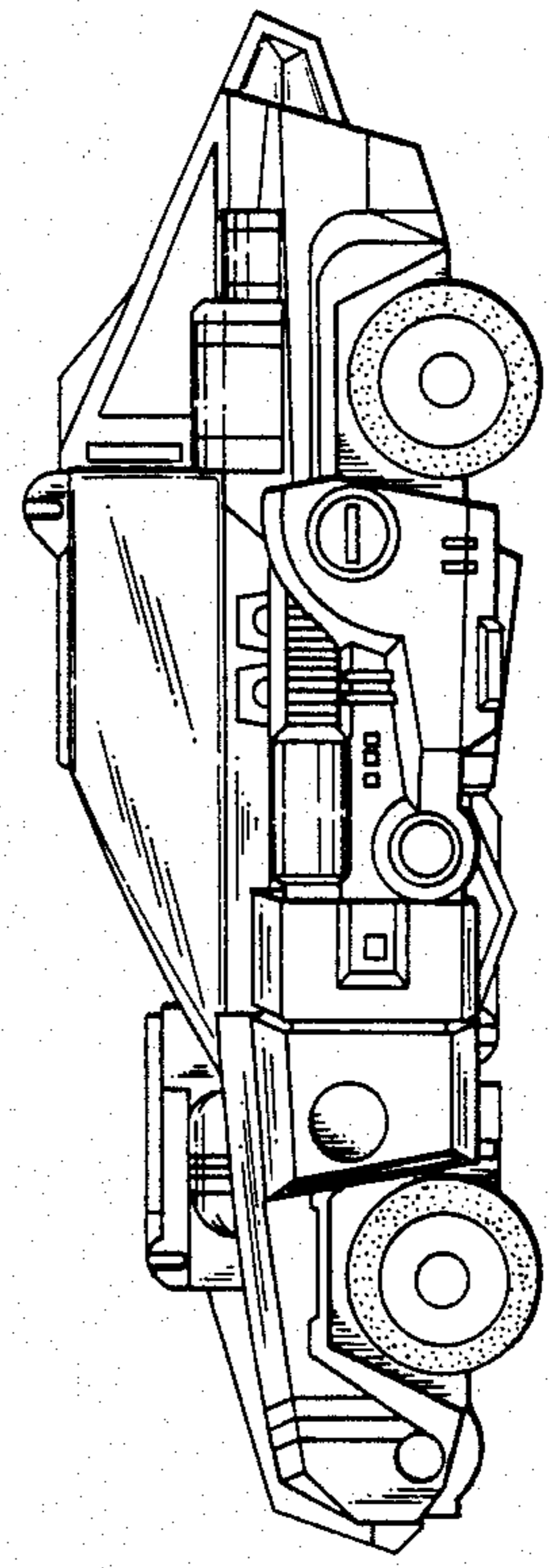

FIG. 1

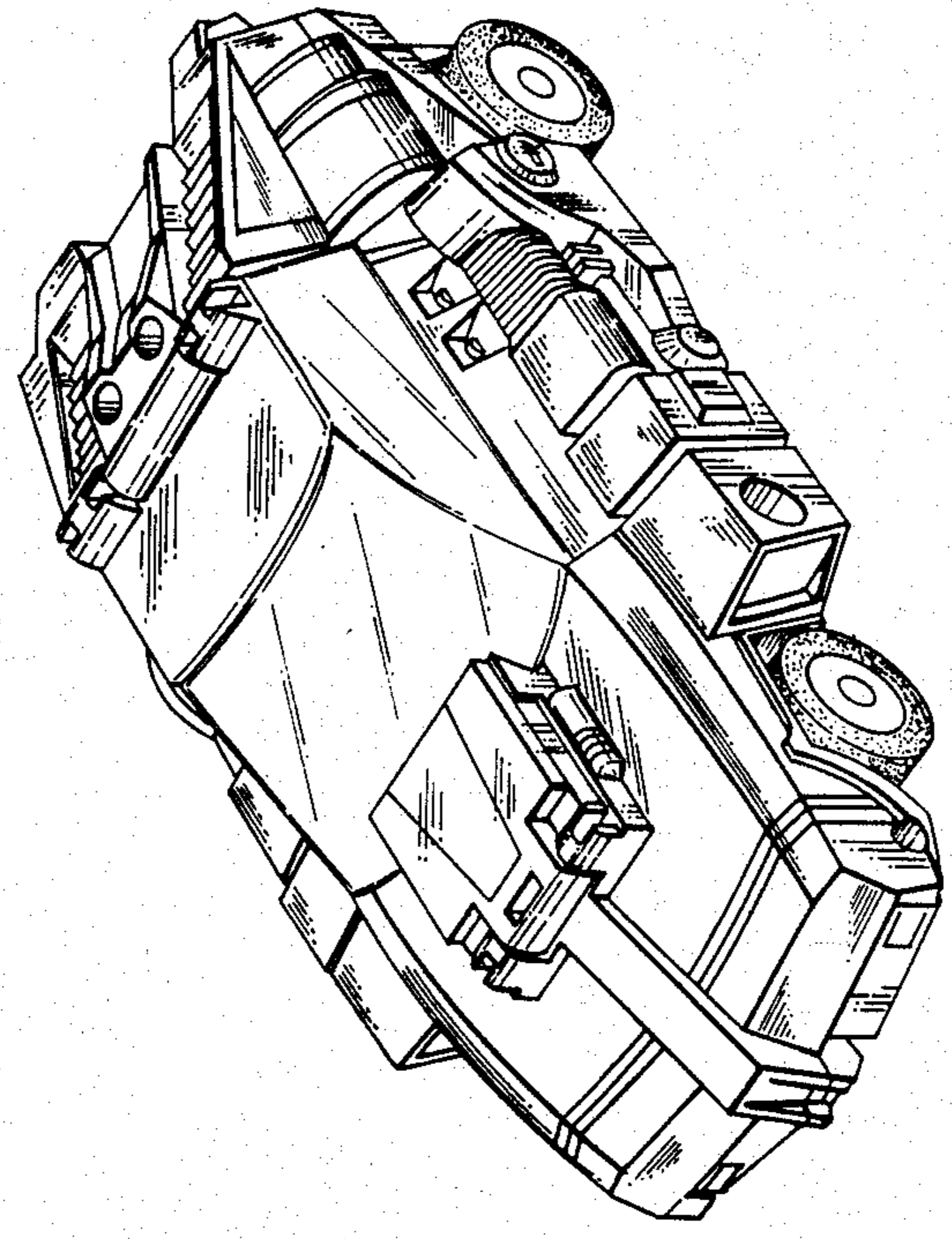

FIG. 4

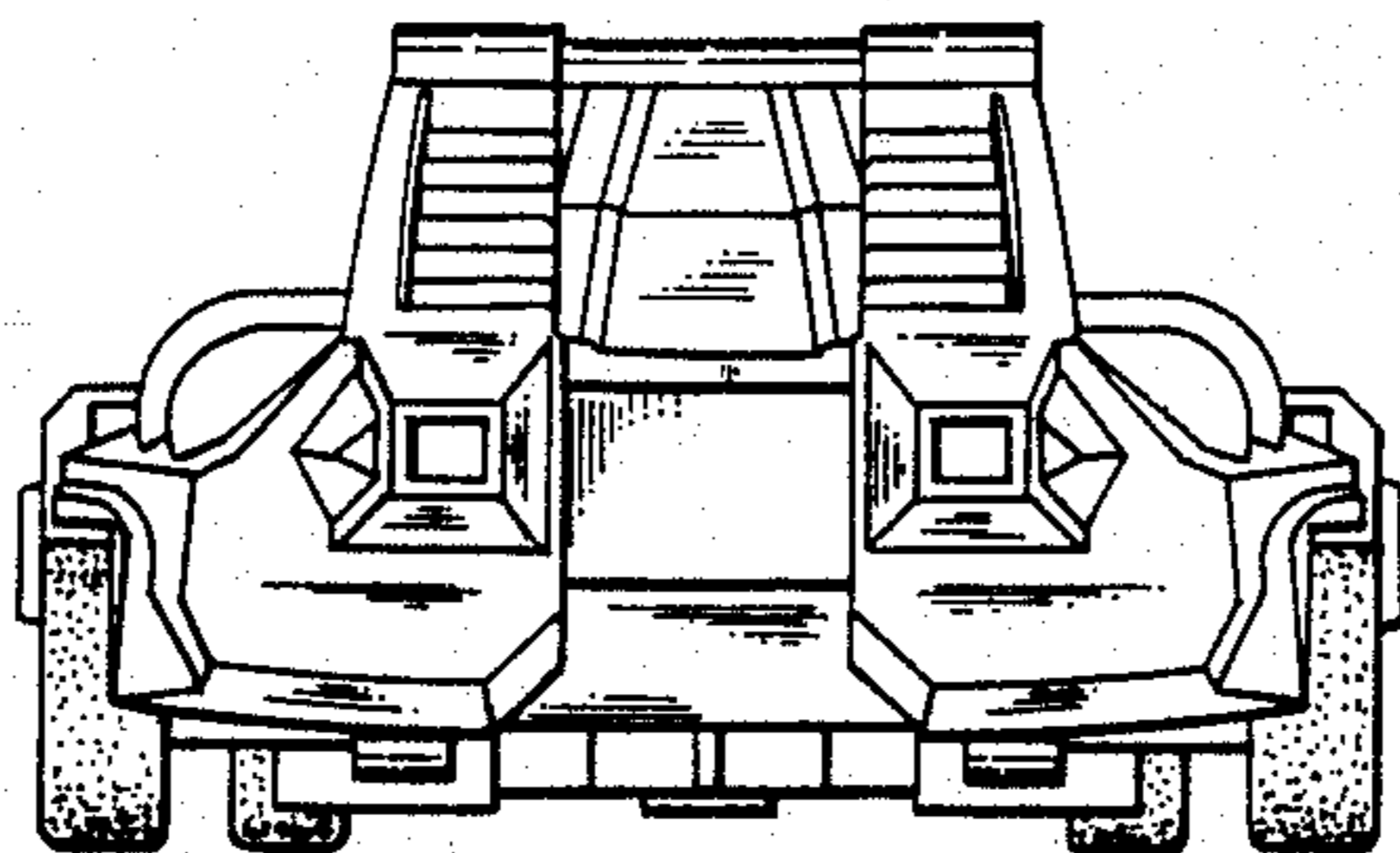

FIG. 5

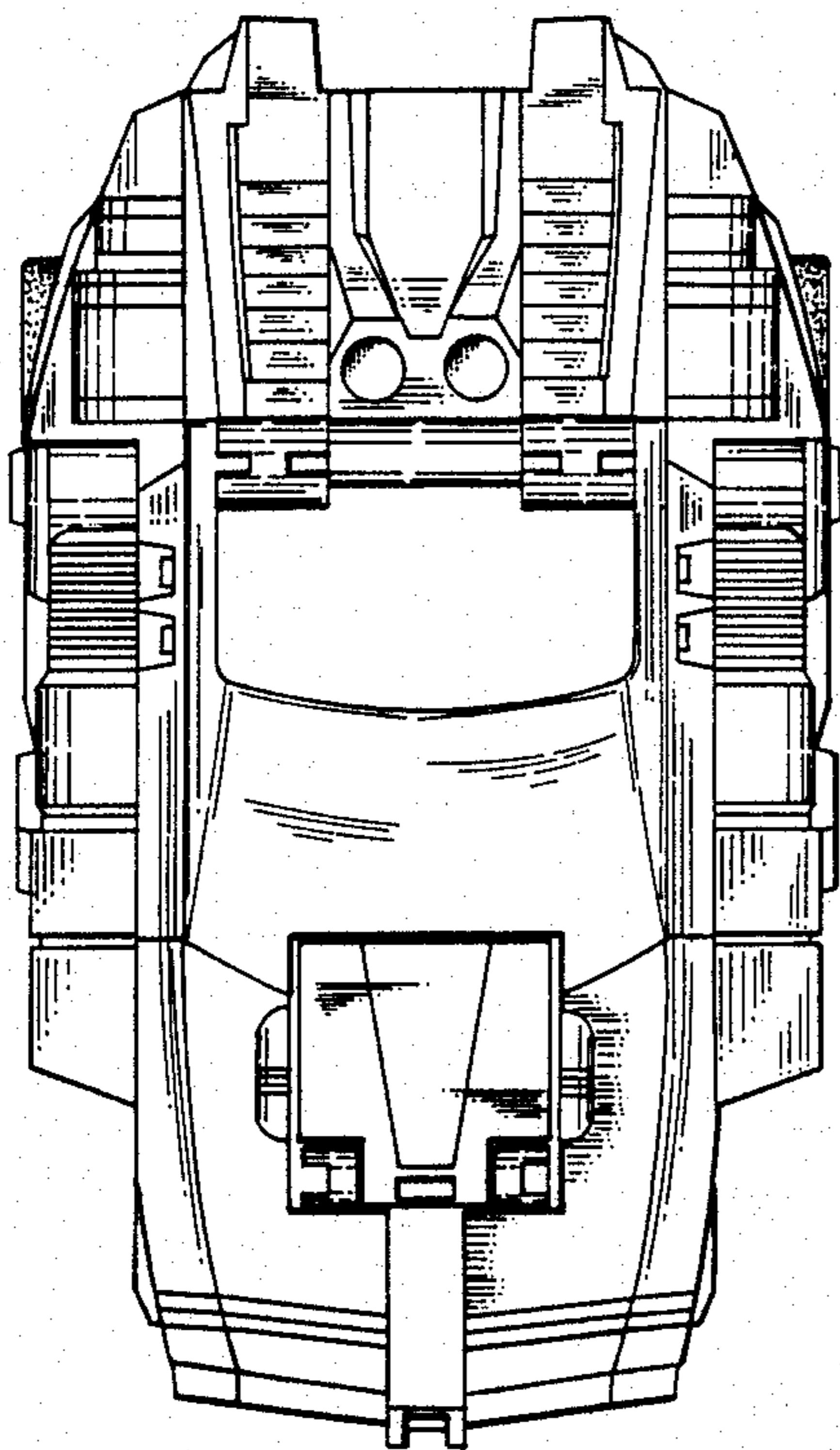

FIG. 6

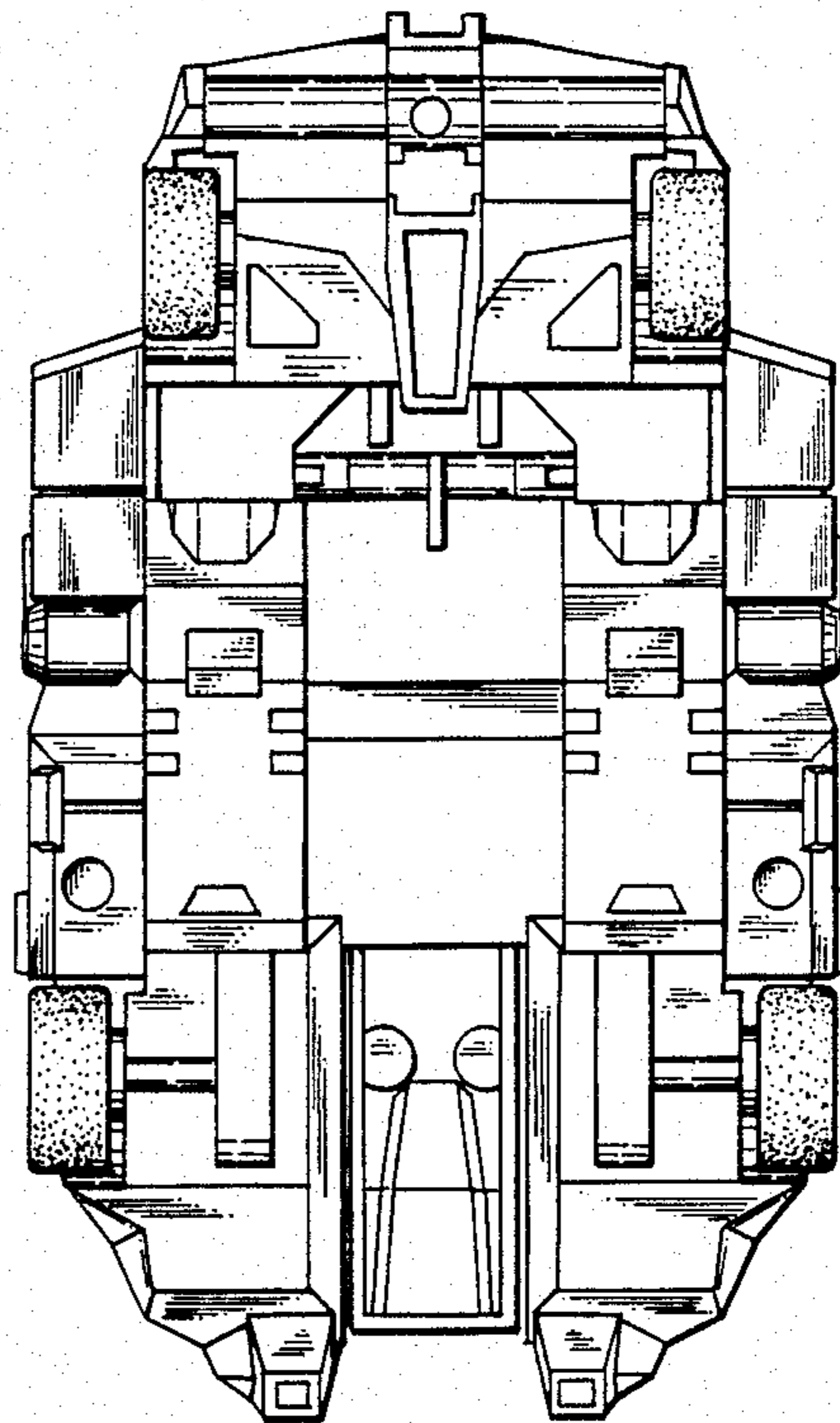

FIG. 9

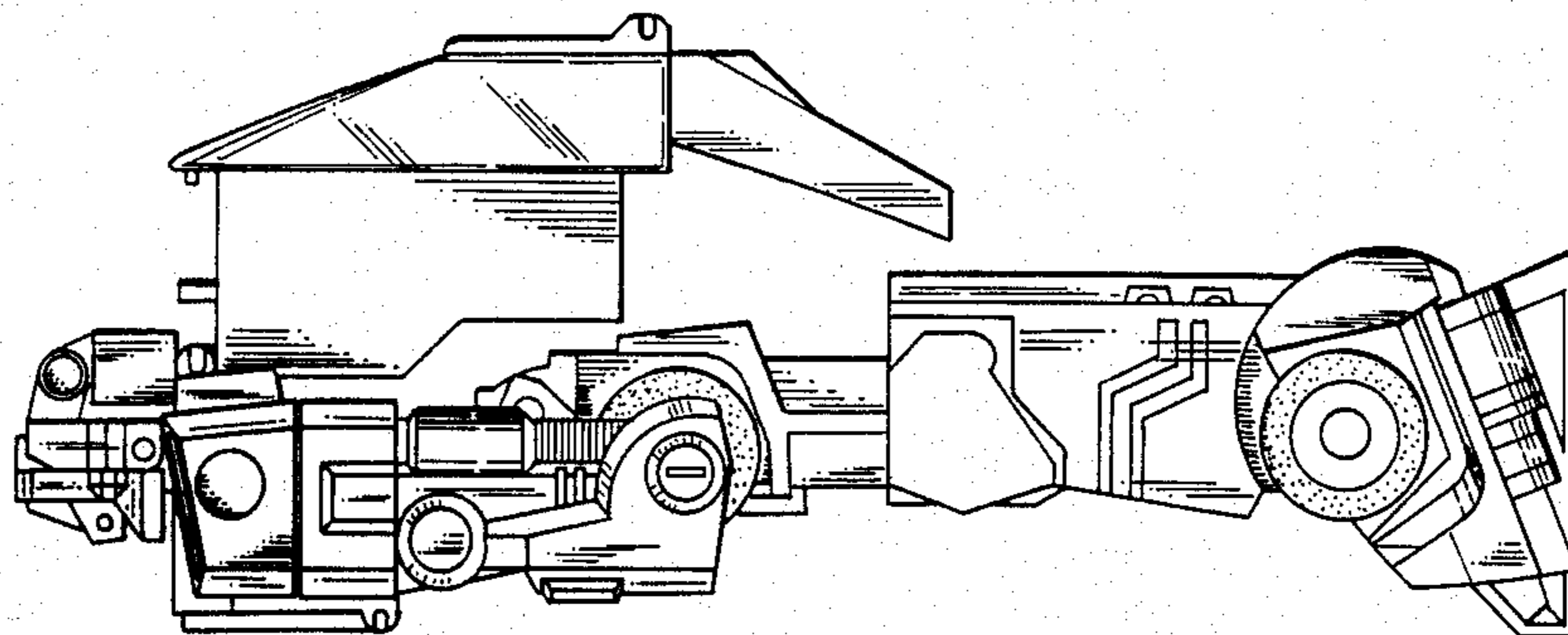

FIG. 8

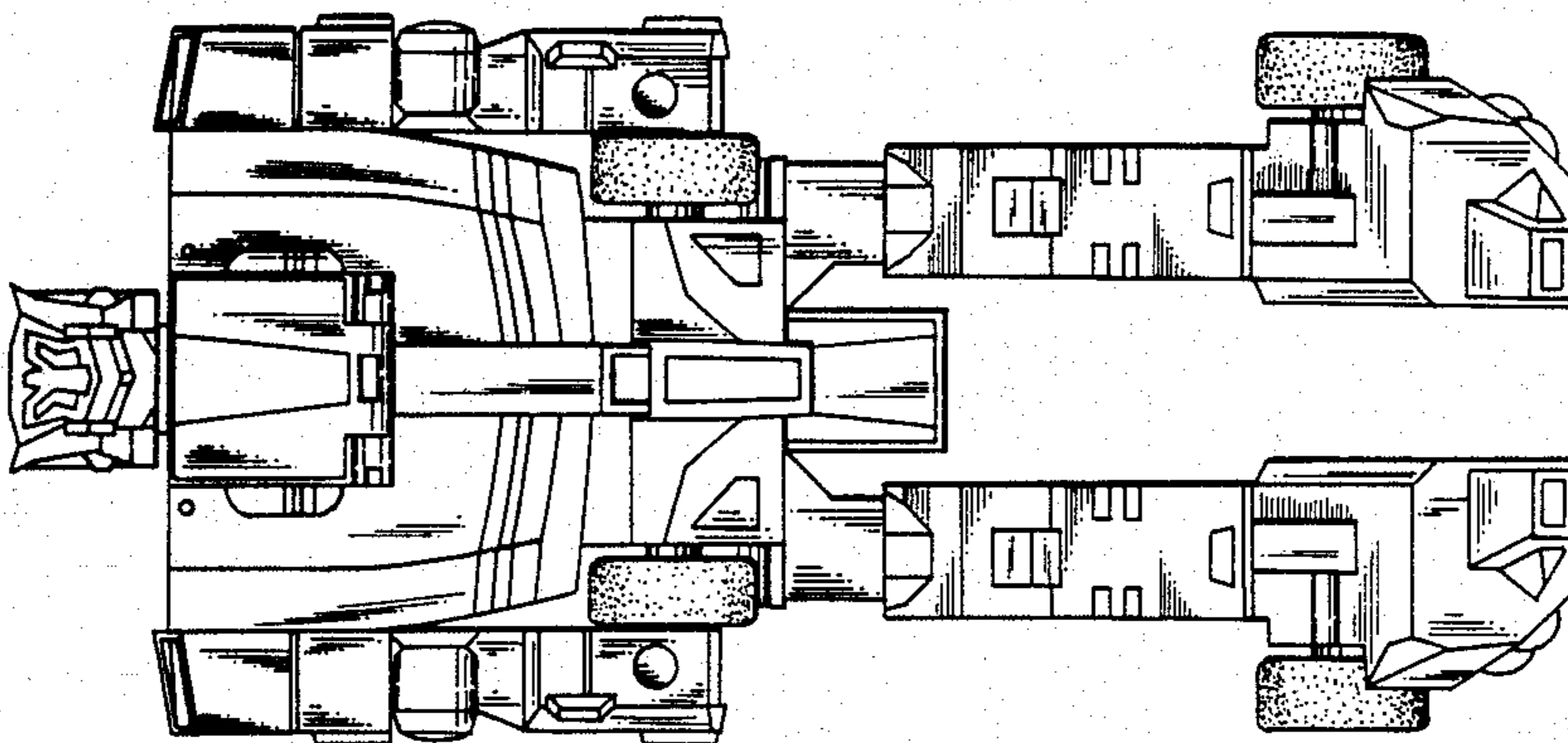

FIG. 7

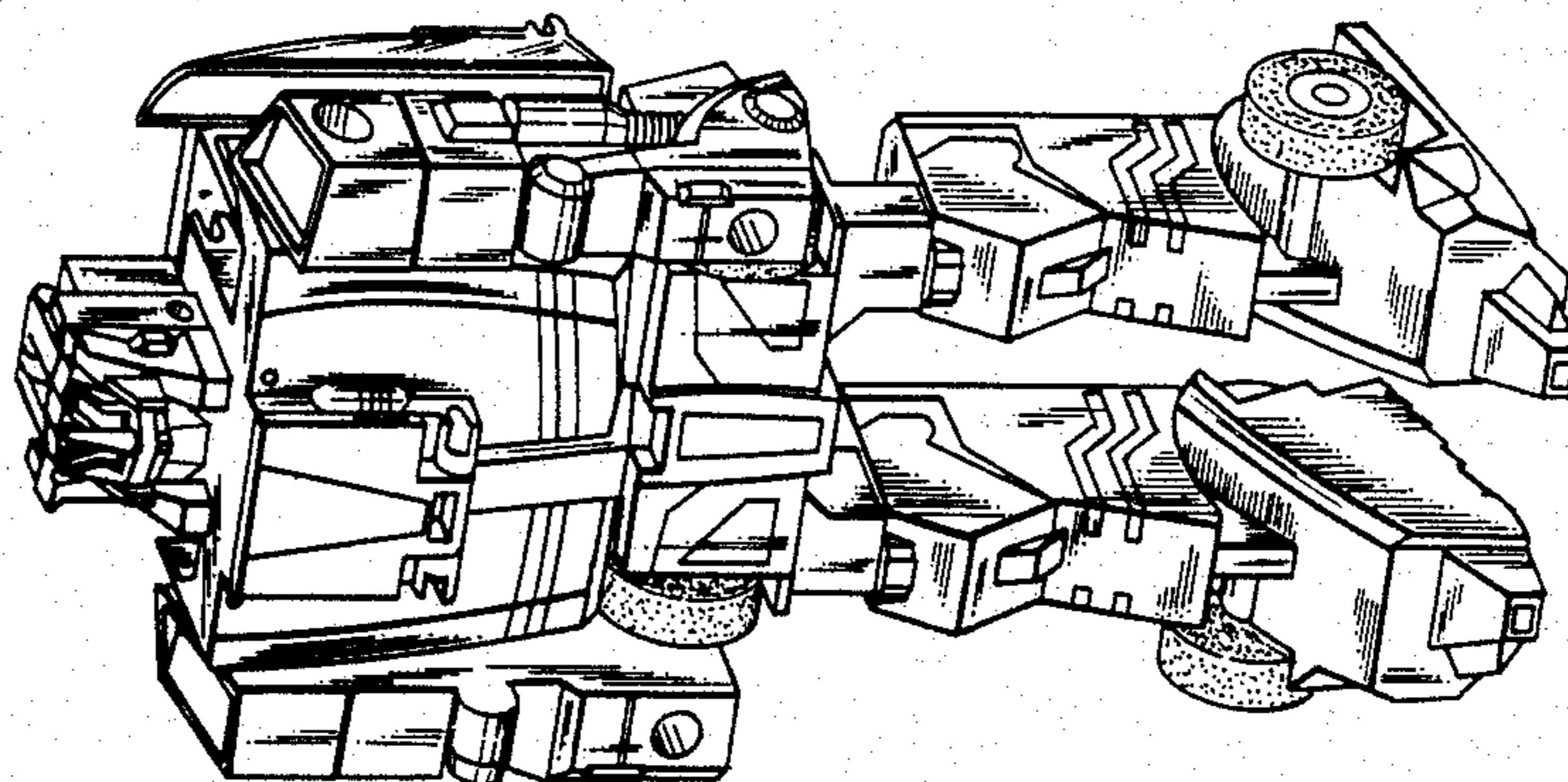

FIG. 11

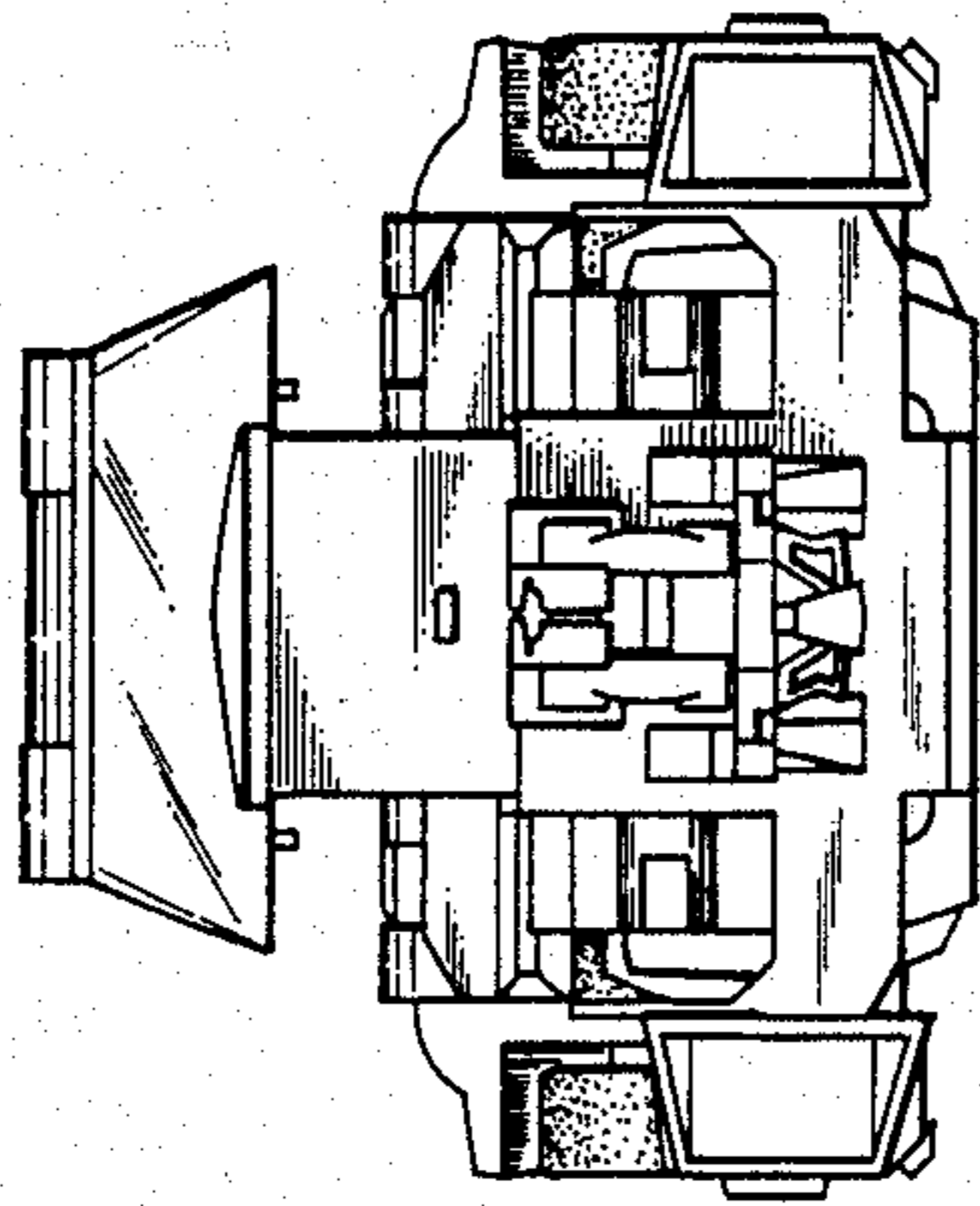

FIG. 12

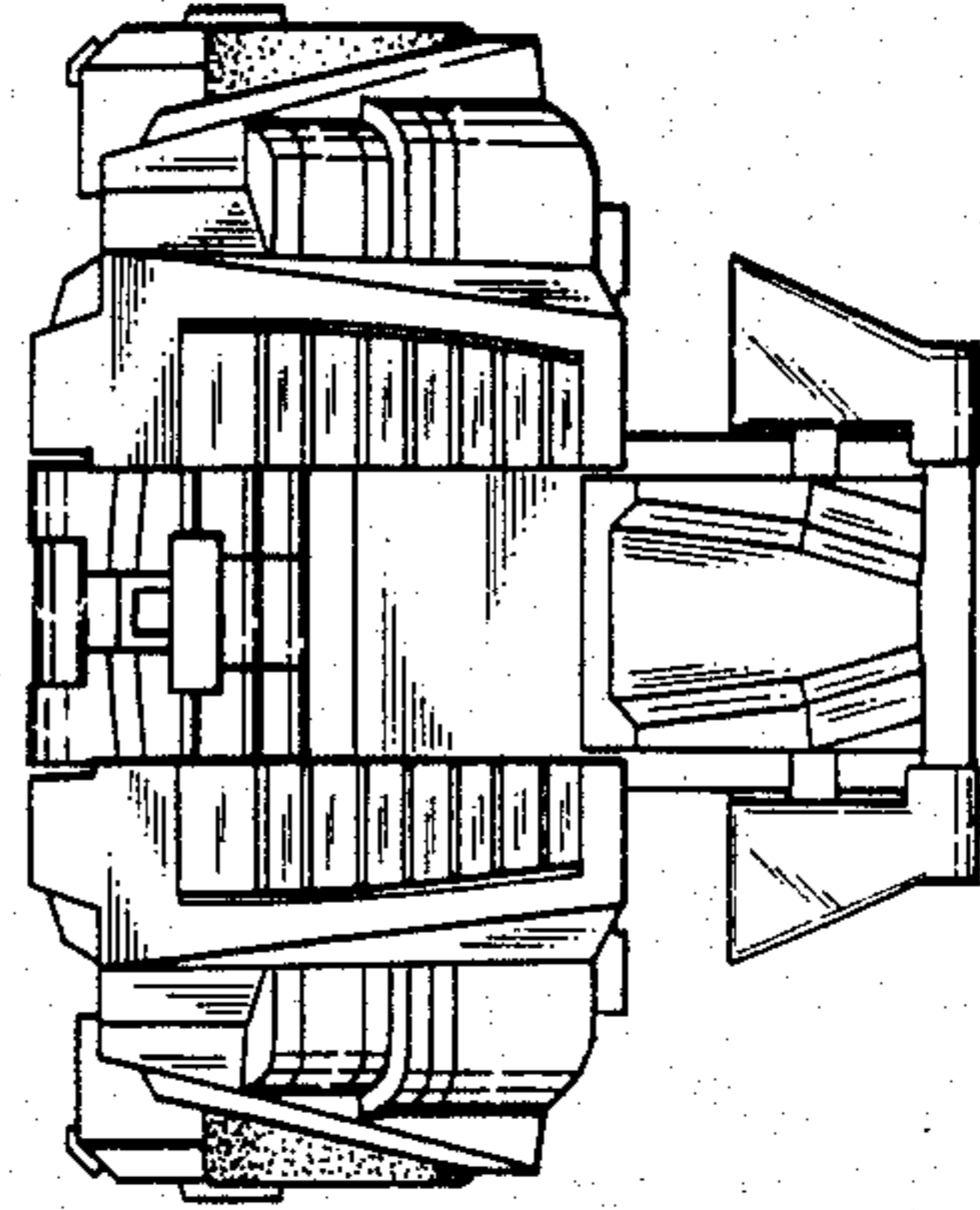

FIG. 10

