

[54] BICYCLE OR SIMILAR ARTICLE

[75] Inventors: Jeffrey L. Bleustein, Bayside; Daniel A. Matre, Milwaukee, both of Wis.

[73] Assignee: Harley-Davidson, Inc., Milwaukee, Wis.

[**] Term: 14 Years

[21] Appl. No.: 67,082

[22] Filed: Jun. 25, 1987

[52] U.S. Cl. D12/111; D12/110

[58] Field of Search D12/111, 110; 280/281 R, 281 LP, 281 W

[56] References Cited

U.S. PATENT DOCUMENTS

D. 246,171	10/1977	Dodd	D12/111
D. 248,634	7/1978	Souza et al.	D12/111
D. 299,220	1/1989	Trusky	D12/111
2,535,540	12/1950	Lechmere	D12/110

FOREIGN PATENT DOCUMENTS

3411046	9/1985	Fed. Rep. of Germany	280/274
702611	9/1930	France	280/281 R

OTHER PUBLICATIONS

Indian Motorcycles Brochure, p. 9, Model 541 Motorcycle.

Primary Examiner—James M. Gandy
Attorney, Agent, or Firm—Fred Wiviott

[57] CLAIM

The ornamental design for a bicycle or similar article, as shown.

DESCRIPTION

FIG. 1 is a right side perspective view of a bicycle or similar article showing our new design; FIG. 2 is a left side perspective view thereof; FIG. 3 is a front elevation view thereof; FIG. 4 is a top plan view thereof; FIG. 5 is a rear elevation view thereof; and FIG. 6 is a bottom plan view thereof.

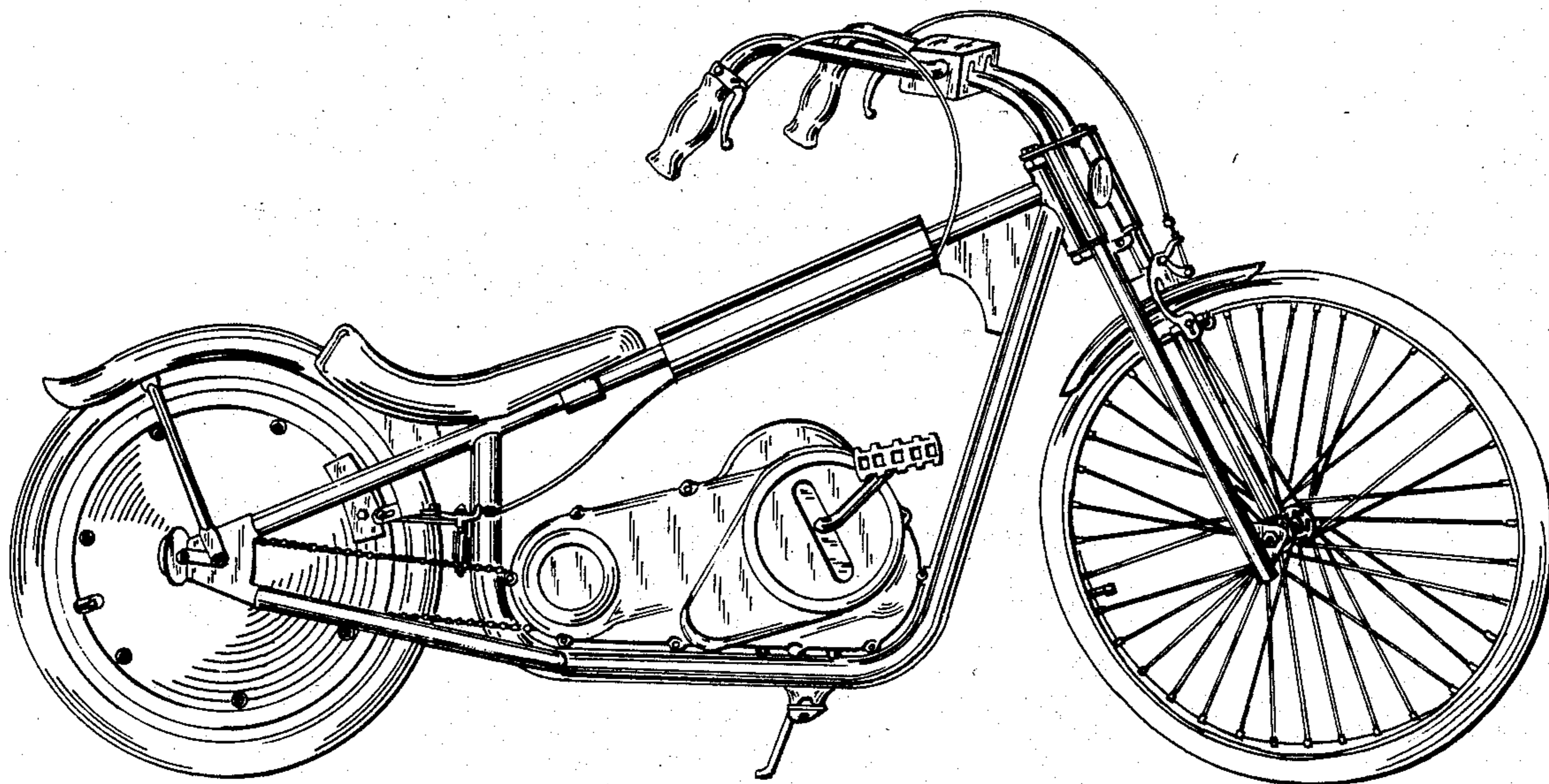

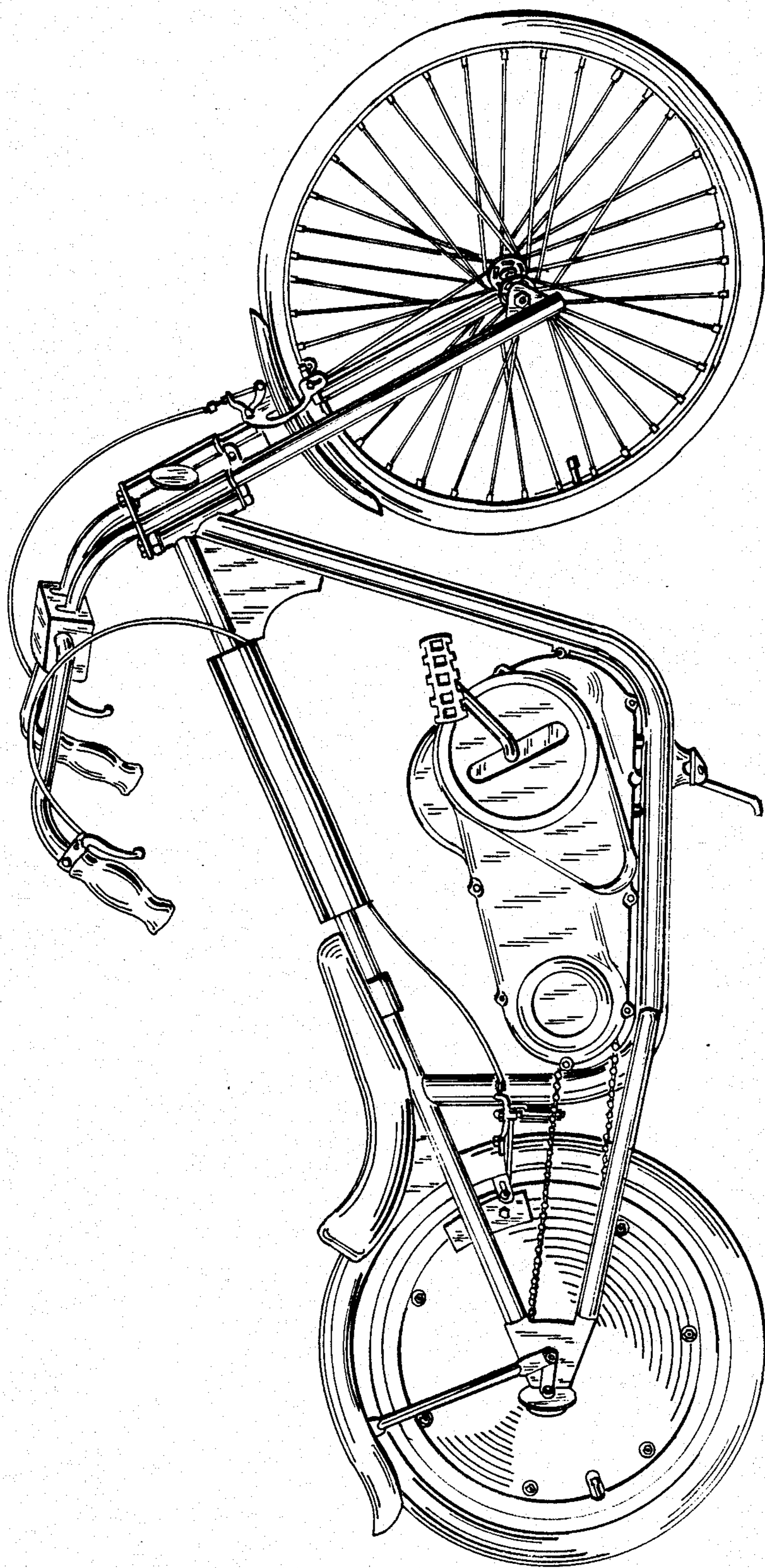

FIG. 1

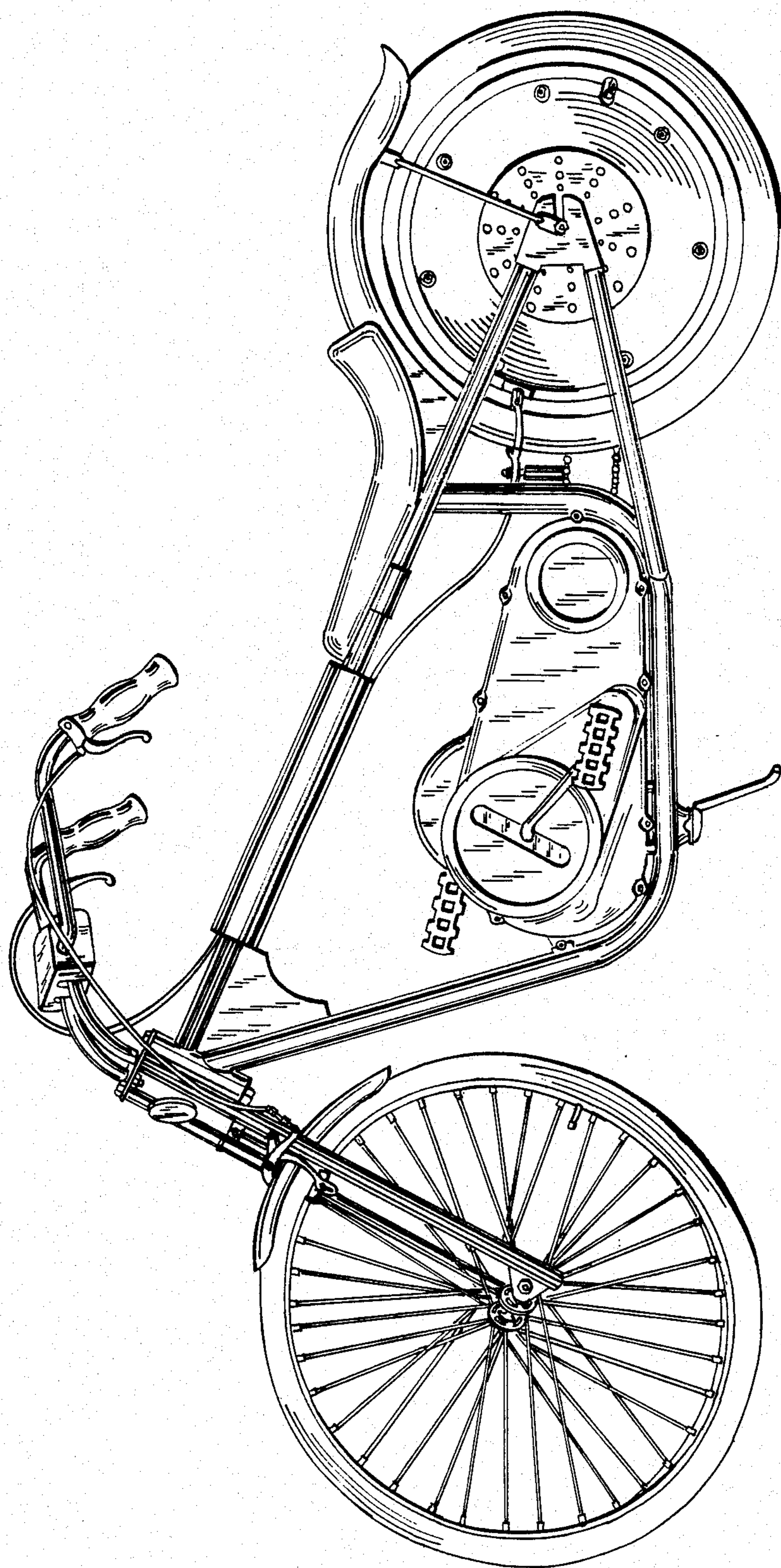

FIG. 2

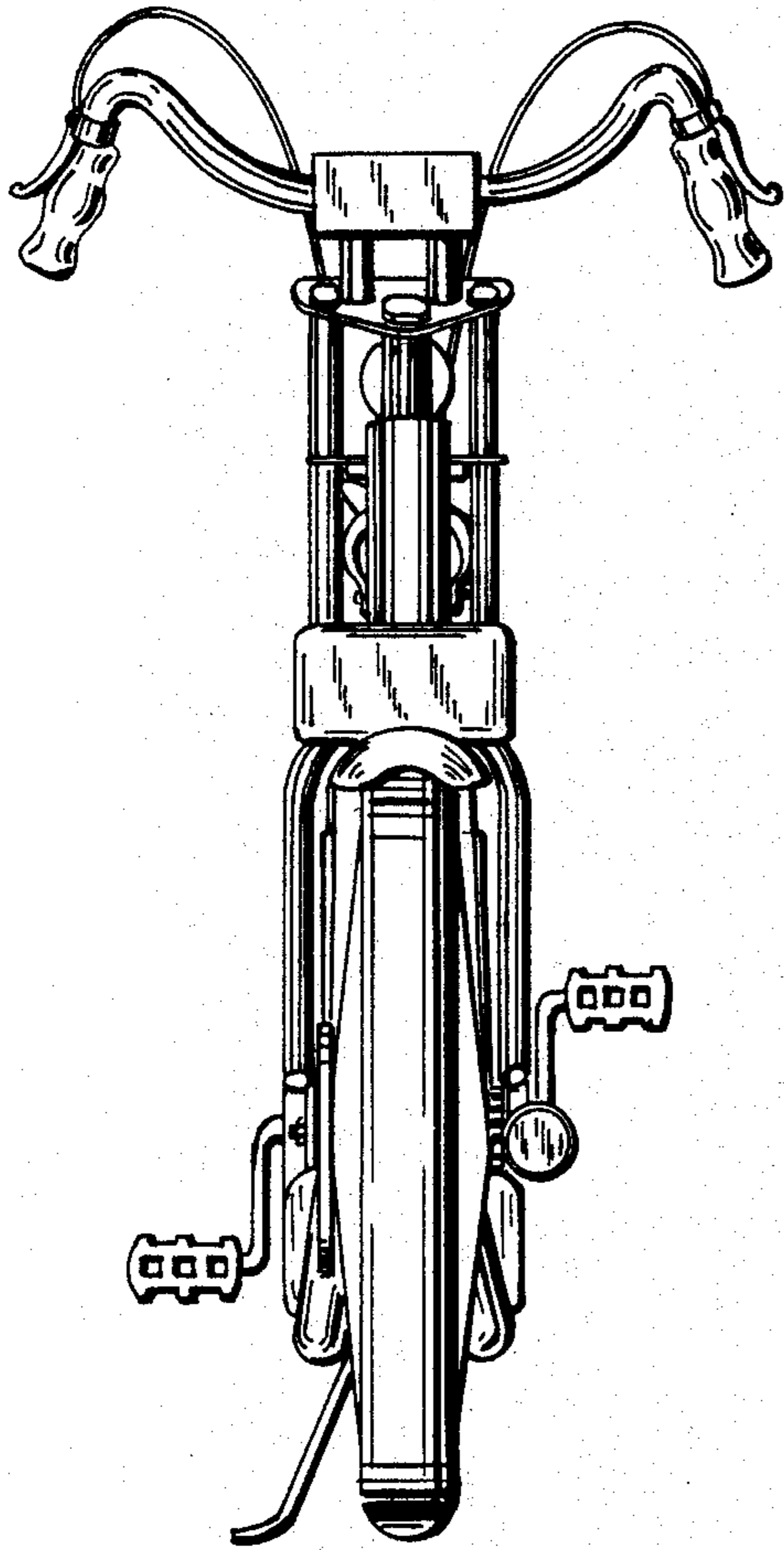

FIG. 5

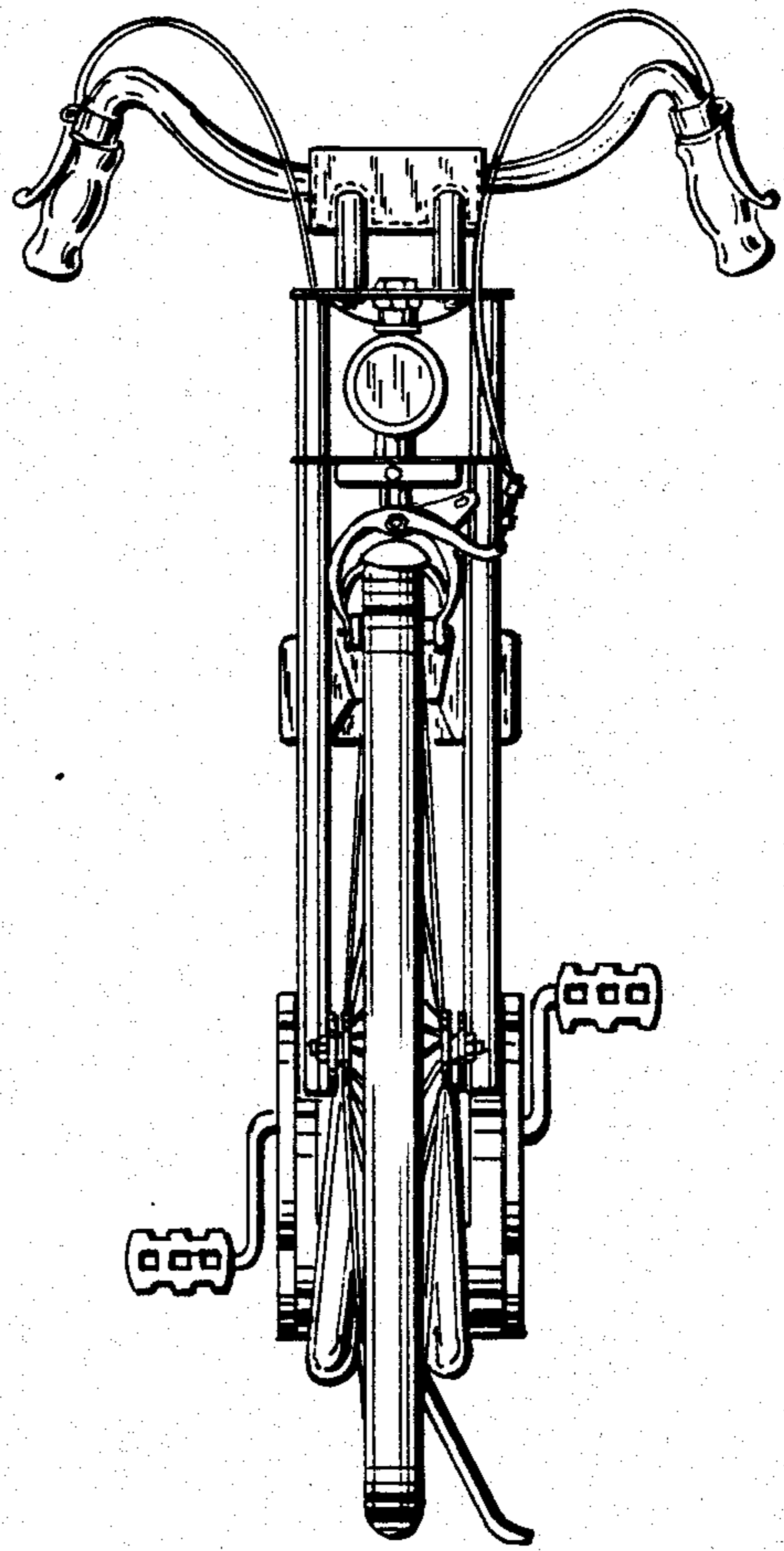

FIG. 3

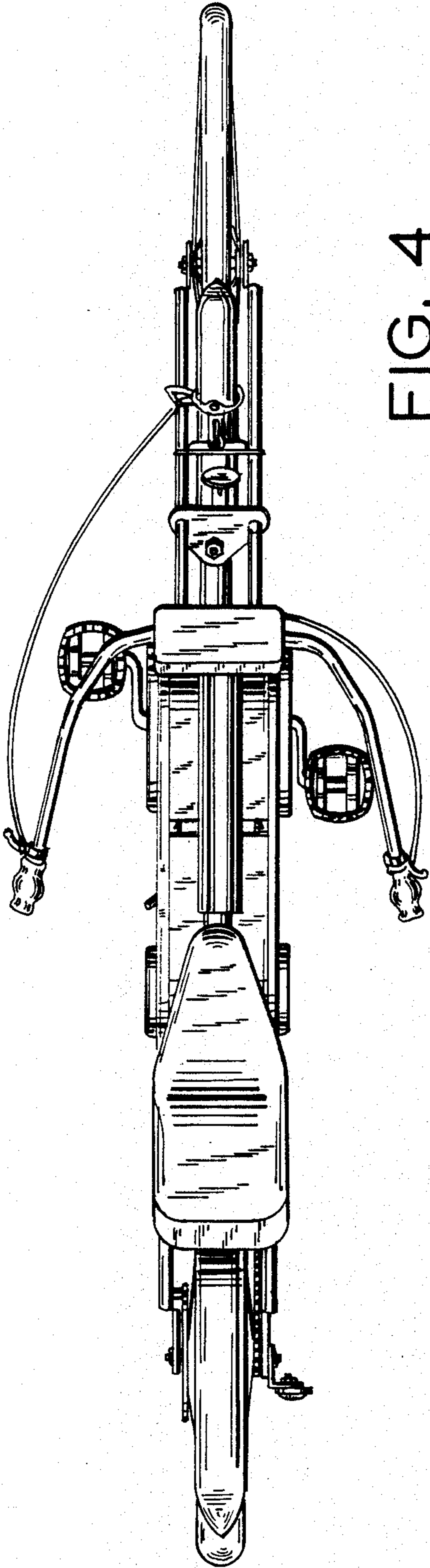

FIG. 4

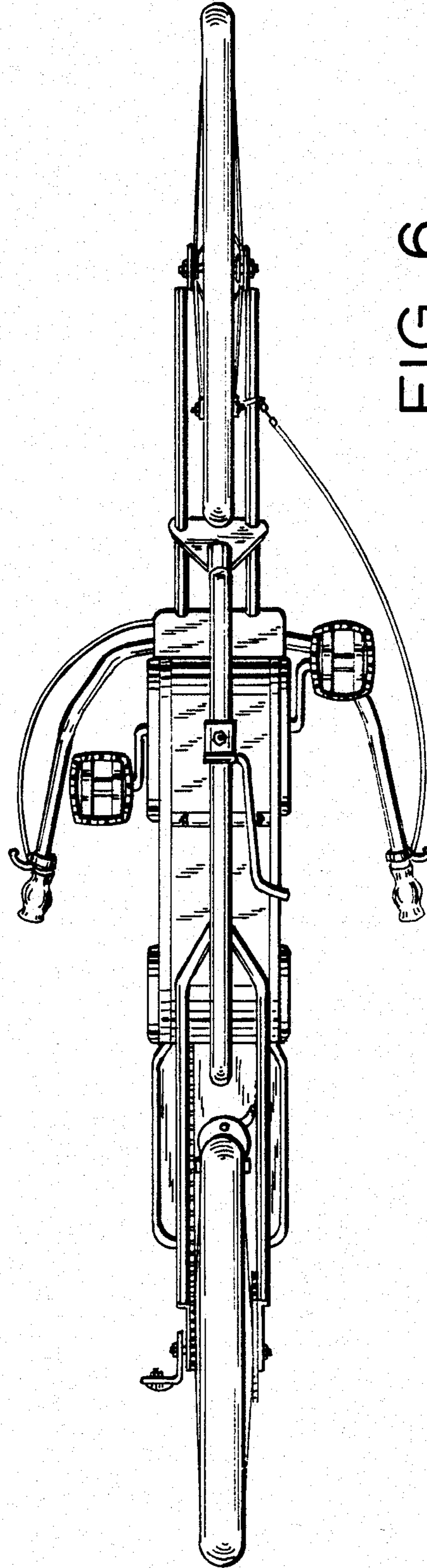

FIG. 6