

[54] **AUTOMOBILE**

D. 272,332 1/1984 Ritchie ..... D12/91

[76] **Inventor: Chris D. Unger, 120-B N.  
McPherson, Orange, Calif. 92669**

[ \* ] **Notice: The portion of the term of this patent  
subsequent to May 30, 2003 has been  
disclaimed.**

[\*\*] **Term: 14 Years**

[21] **Appl. No.: 930,852**

[22] **Filed: Nov. 13, 1986**

[52] **U.S. Cl. .... D12/92**

[58] **Field of Search ..... D12/92; 296/185**

[56] **References Cited**

**U.S. PATENT DOCUMENTS**

- D. 159,335 7/1950 Graham ..... D12/92
- D. 233,321 10/1974 Wilfert ..... D12/92
- D. 266,412 10/1982 Deaver ..... D12/156

**OTHER PUBLICATIONS**

Road & Track, 12/84, p. 134, Chevrolet Eurosport  
Convertible, top & bottom of page.  
Motor Trend, 2/82, p. 38, Classic Group's Buick Regal,  
second box down from top left side of page.

*Primary Examiner*—James M. Gandy  
*Attorney, Agent, or Firm*—Boniard I. Brown

[57] **CLAIM**

The ornamental design for an automobile, as shown and  
described.

**DESCRIPTION**

FIG. 1 is a perspective view of an automobile showing  
my new design;  
FIG. 2 is a top plan view thereof;  
FIG. 3 is a side elevational view thereof, the opposite  
side being a mirror image thereto; and  
FIG. 4 is a rear elevational view thereof.

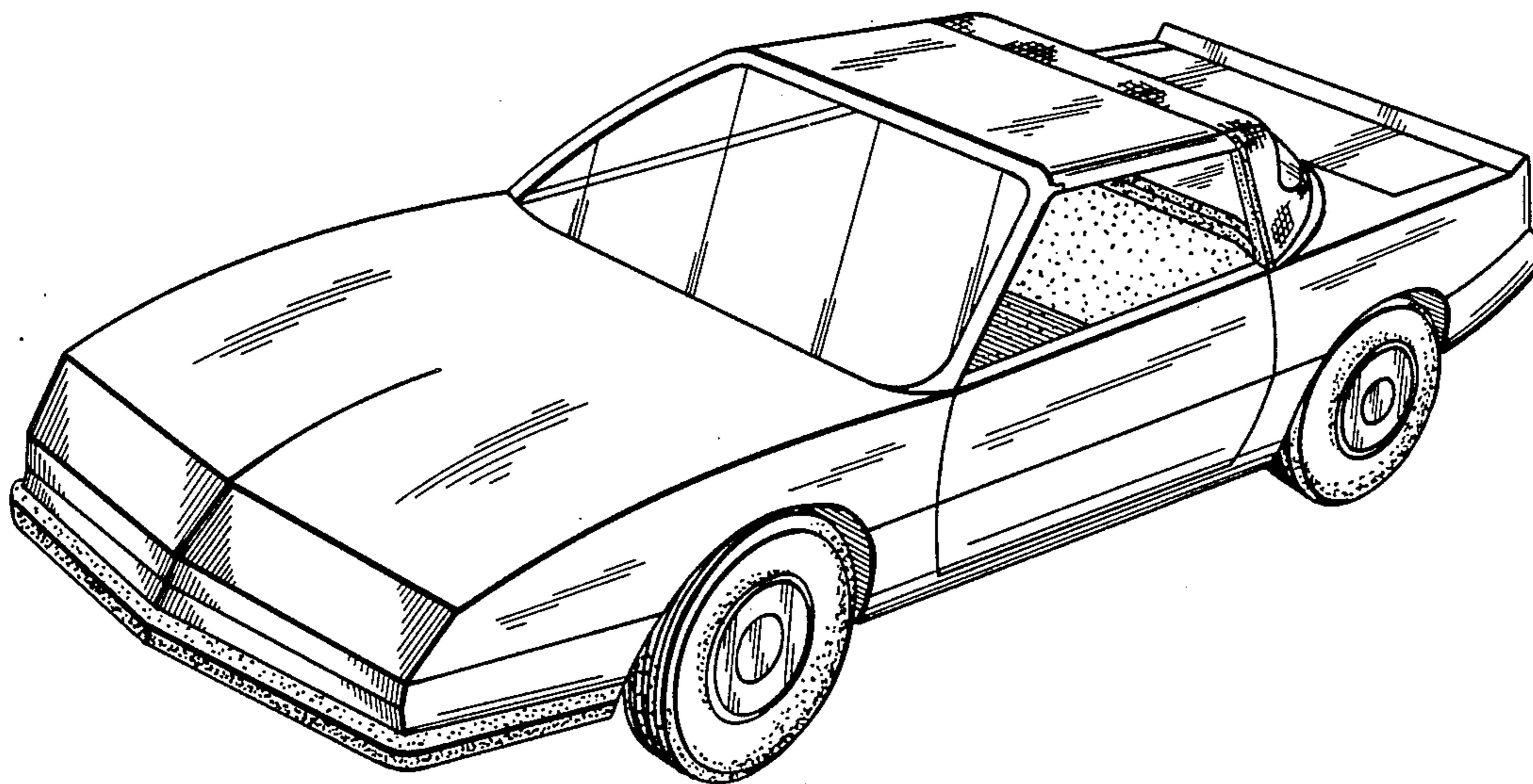

FIG. 1

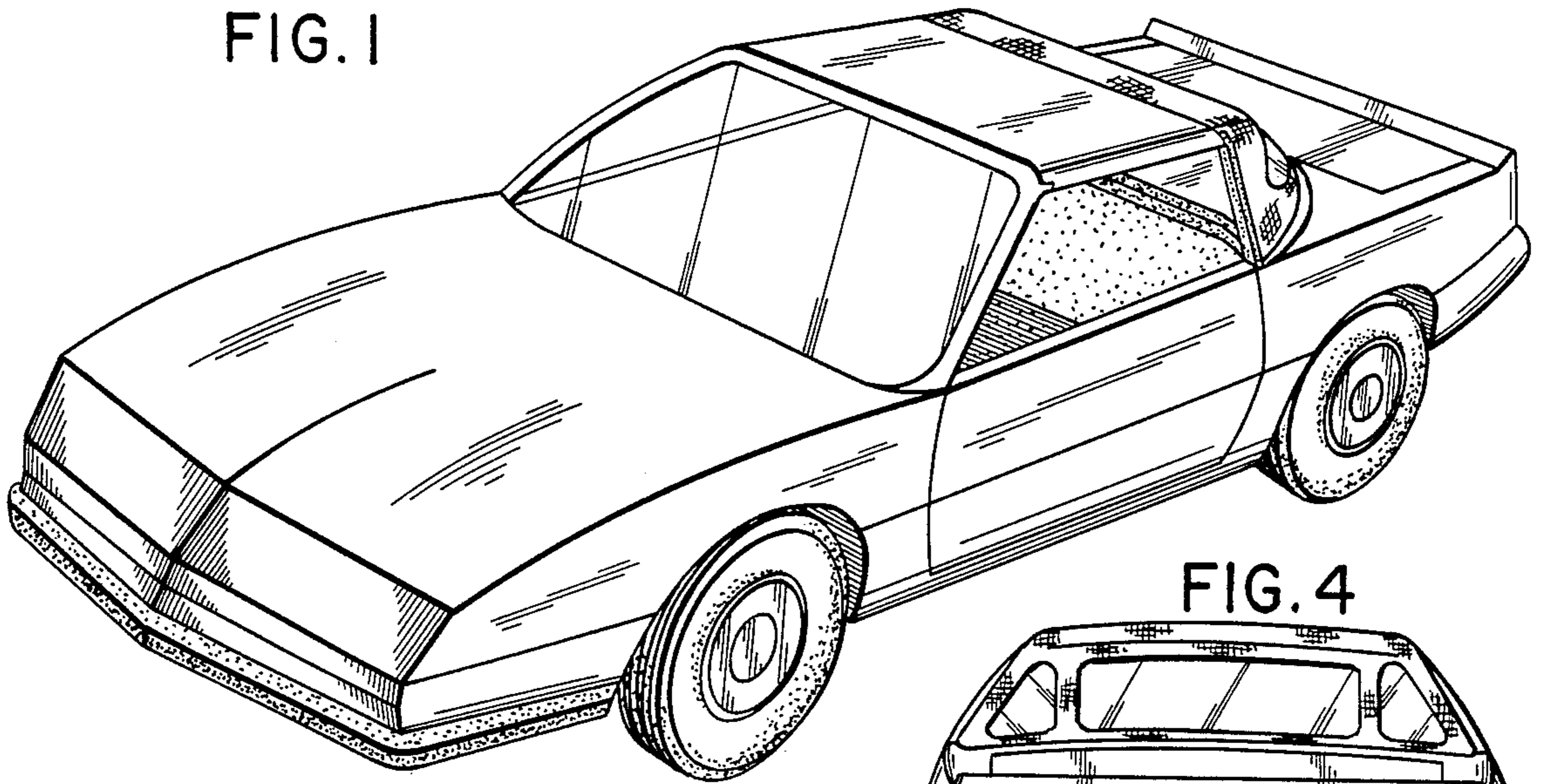

FIG. 4

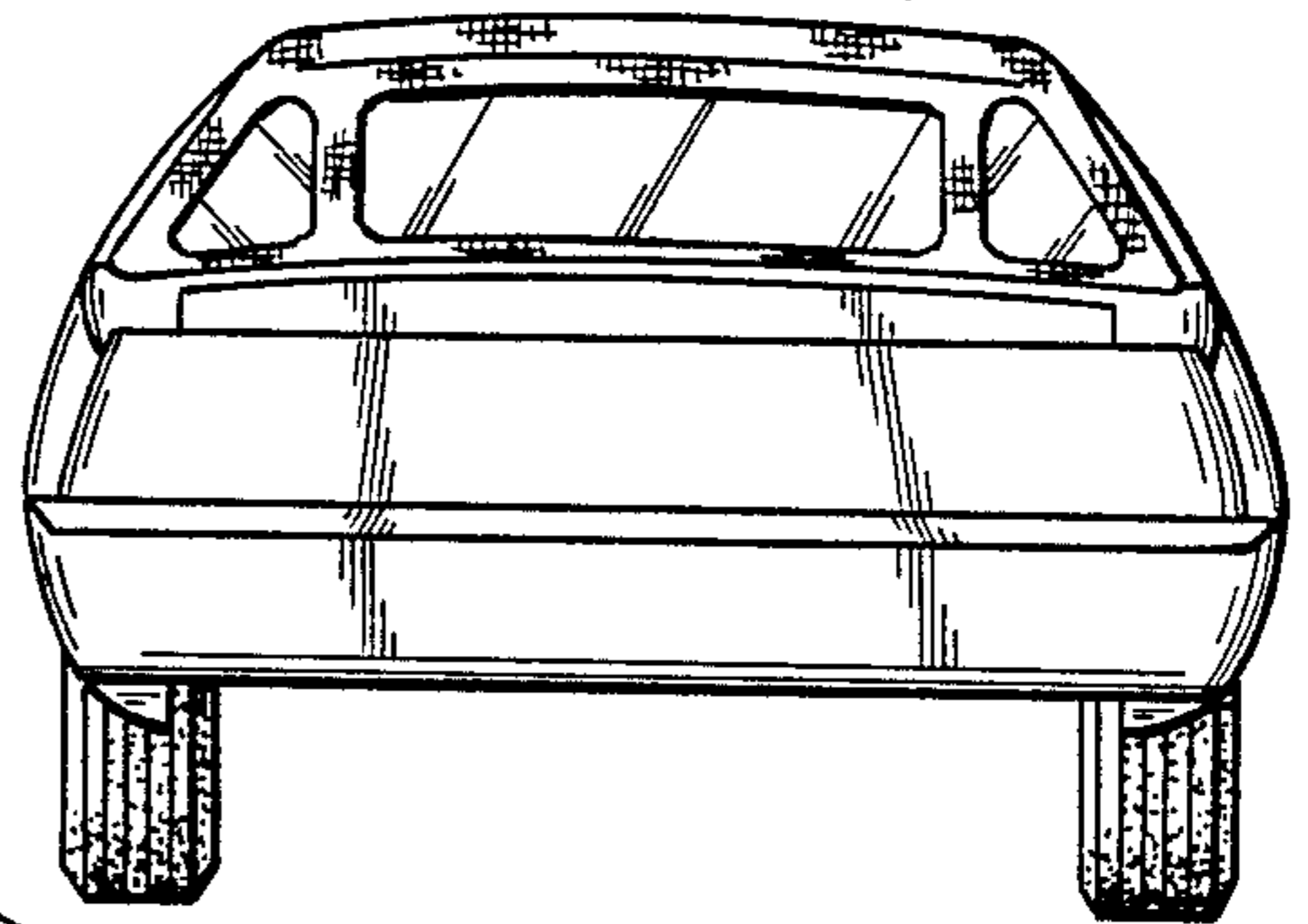

FIG. 2

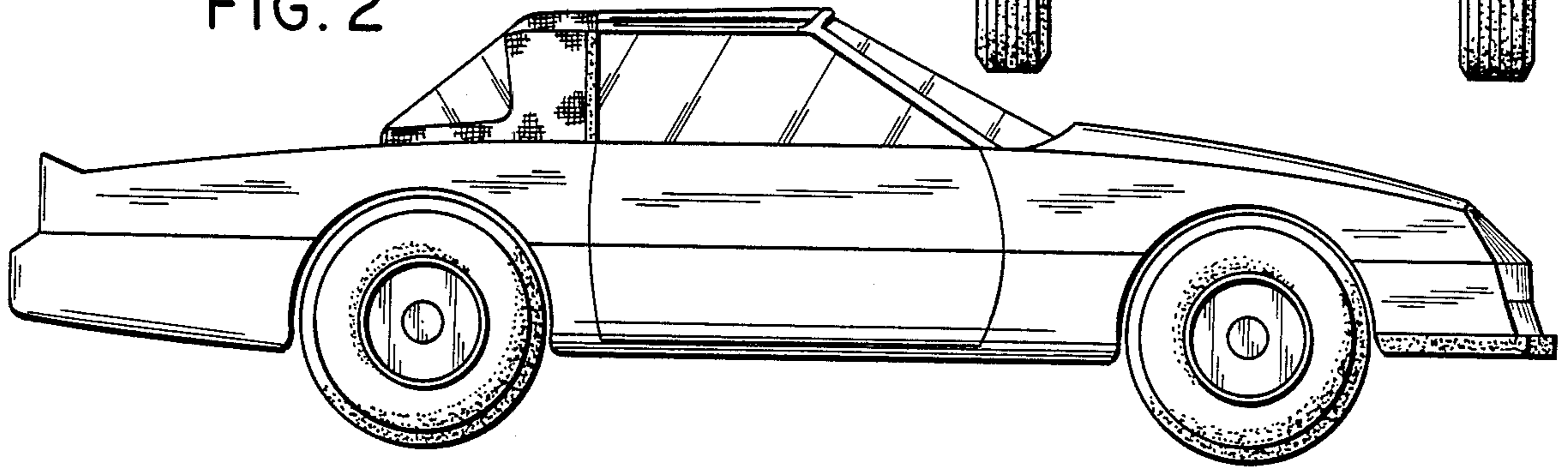

FIG. 3

