

[54] AUTOMOBILE

[76] Inventor: Chris D. Unger, 120-B N. McPherson, Orange, Calif. 92669

[\*] Notice: The portion of the term of this patent subsequent to May 30, 2003 has been disclaimed.

[\*\*] Term: 14 Years

[21] Appl. No.: 930,820

[22] Filed: Nov. 13, 1986

[52] U.S. Cl. .... D12/92

[58] Field of Search ..... D12/92; 296/185

[56] References Cited

U.S. PATENT DOCUMENTS

D. 272,332 1/1984 Ritchie ..... D12/91

OTHER PUBLICATIONS

Road & Track, 12/84, Chevrolet Eurosport Convertible, top & bottom of page.

1983 Pontiac brochure, p. 36, Pontiac 2000 Sunbird Convertible. 1983 Chrysler LeBaron brochure, p. 5, LeBaron Convertible.

Primary Examiner—James M. Gandy  
Attorney, Agent, or Firm—Boniard I. Brown

[57] CLAIM

The ornamental design for an automobile, as shown and described.

DESCRIPTION

FIG. 1 is a perspective view of an automobile showing my new design;

FIG. 2 is a top plan view thereof;

FIG. 3 is a side elevational view thereof, the opposite side being a mirror image thereto;

FIG. 4 is a front elevational view thereof; and

FIG. 5 is a rear elevational view thereof.

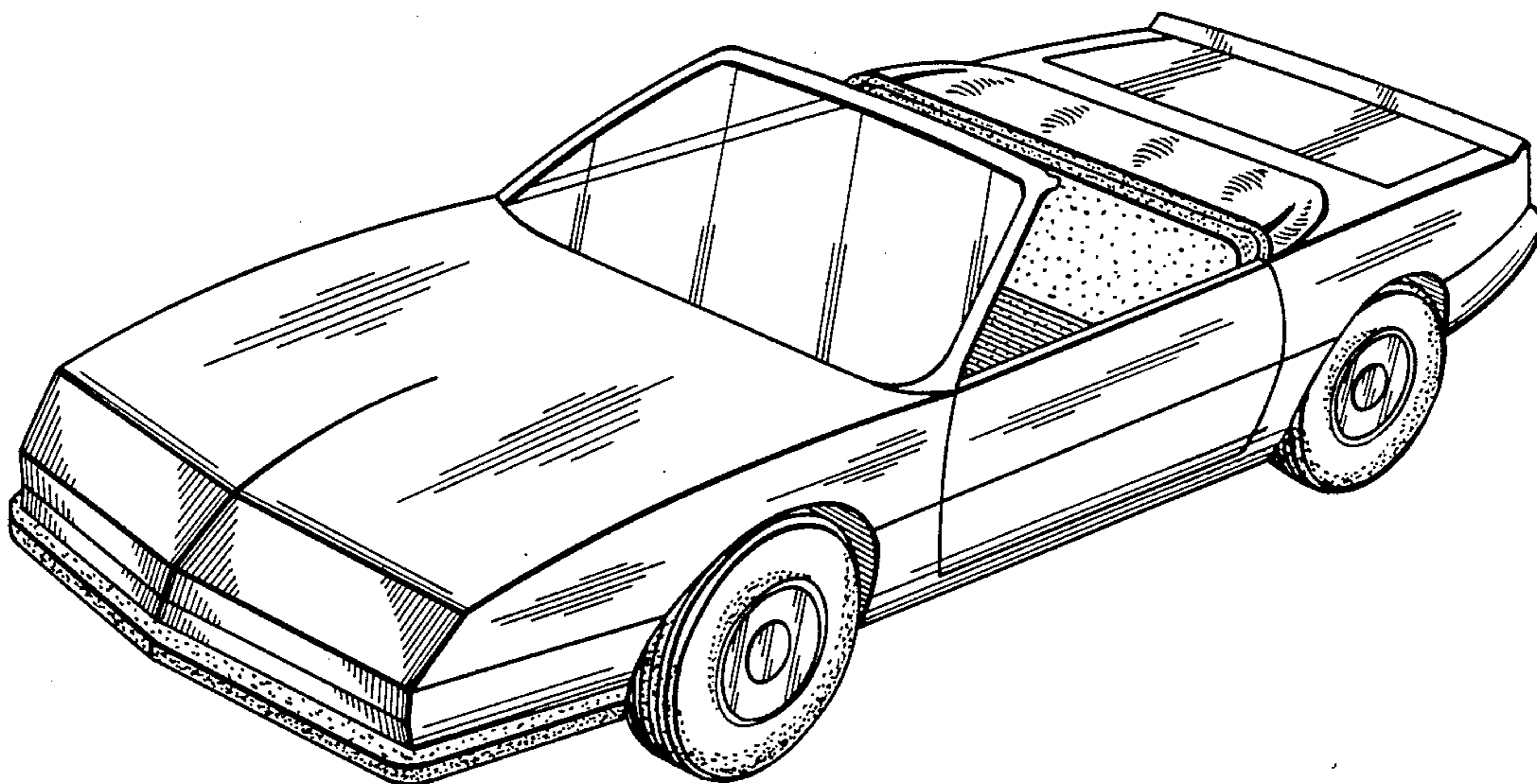

FIG. 1

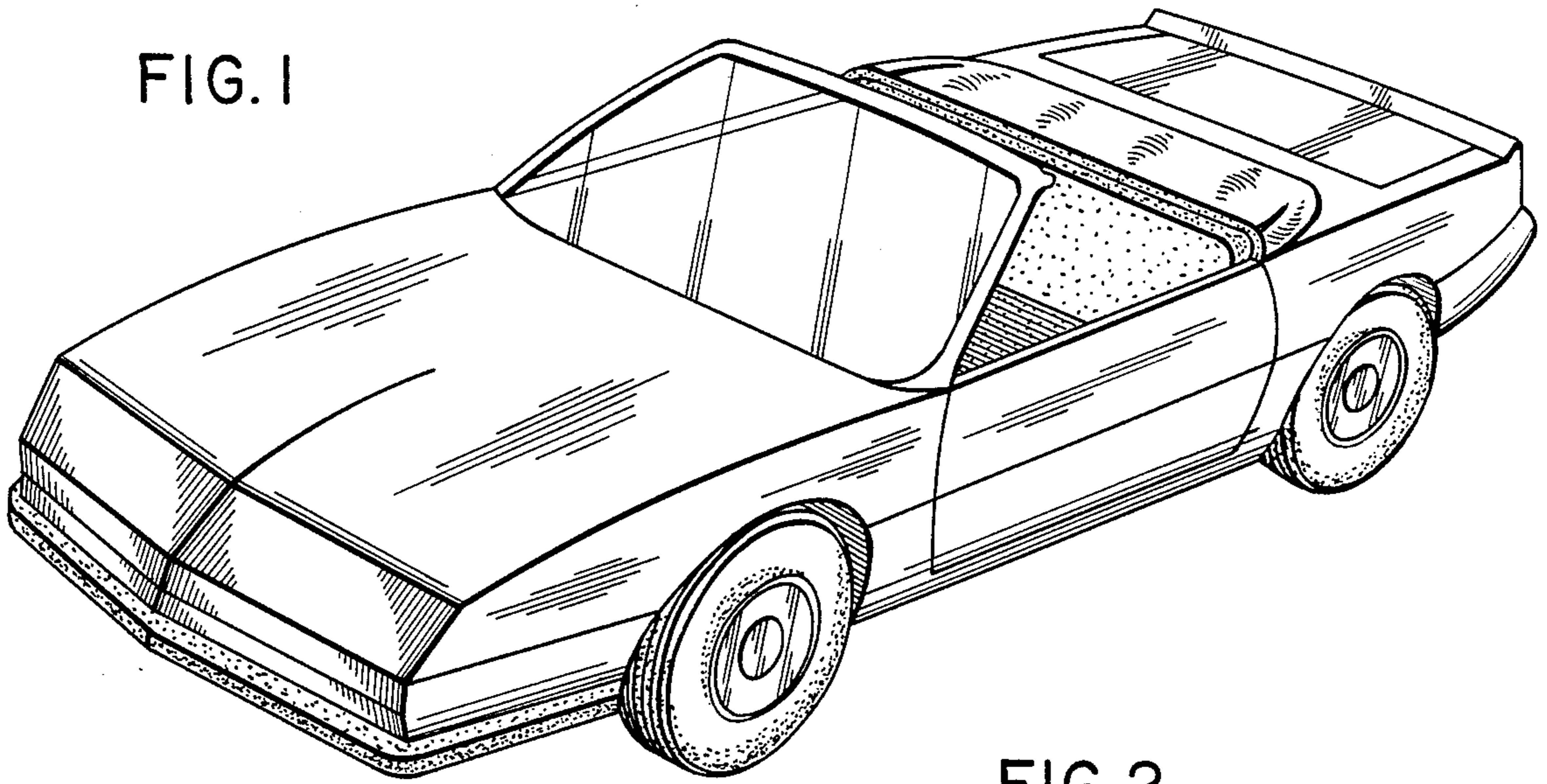

FIG. 2

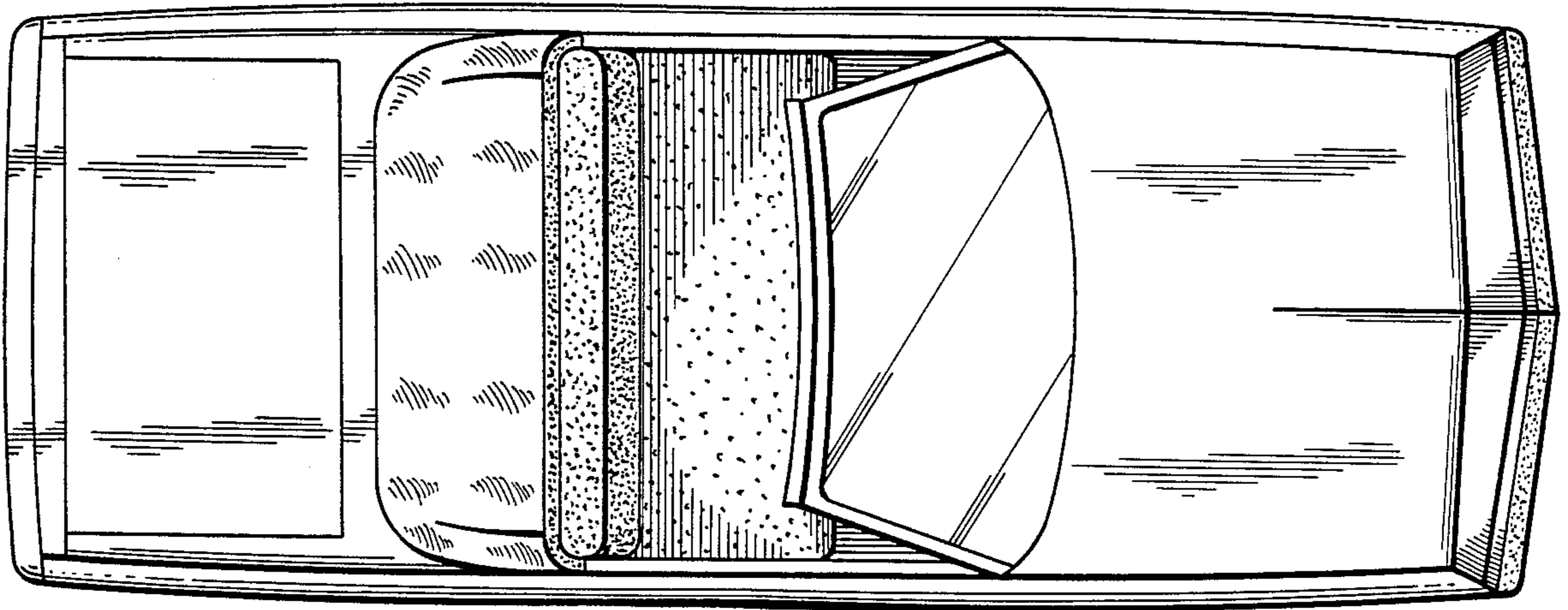

FIG. 3

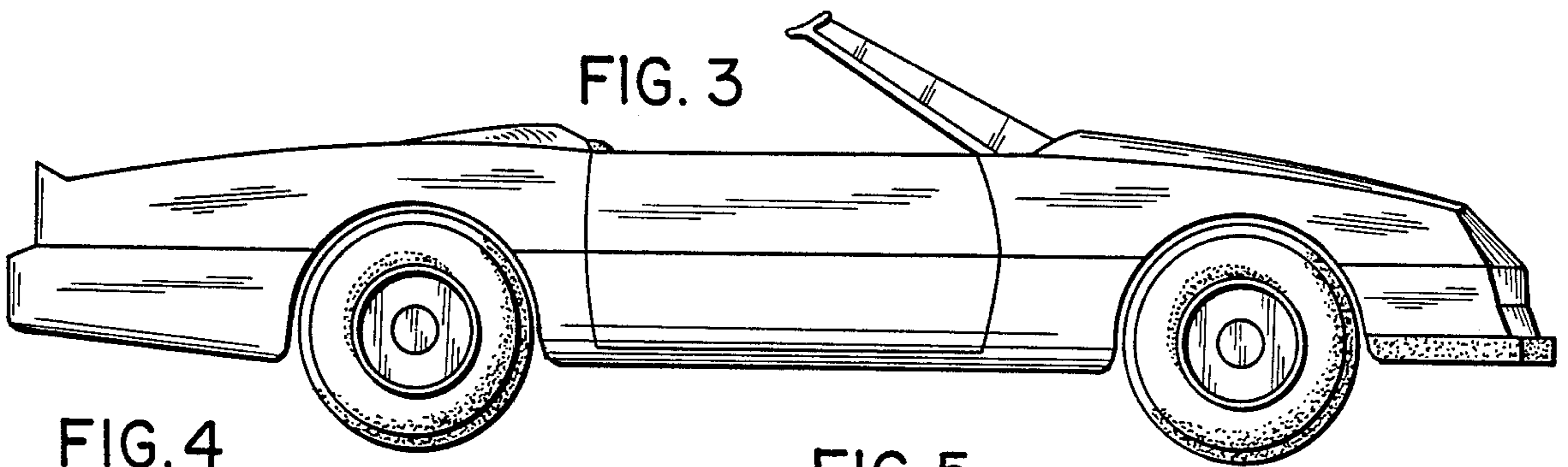

FIG. 4

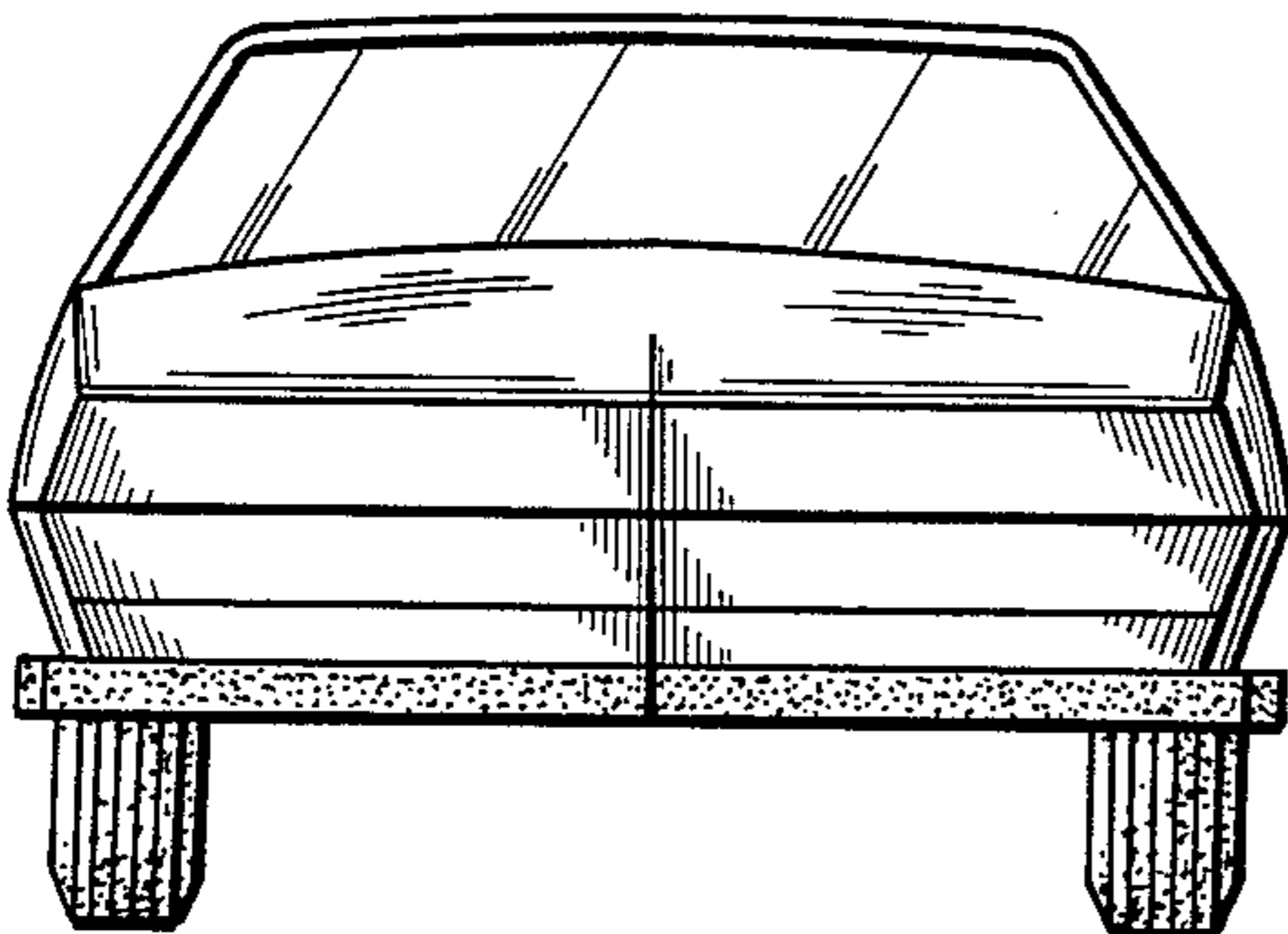

FIG. 5

