

[54] TIRE ANTI-SKID UNIT

[76] Inventor: Donnie R. Smith, P.O. Box 14342, Greensboro, N.C. 27415

[**] Term: 14 Years

[21] Appl. No.: 923,720

[22] Filed: Oct. 24, 1986

[52] U.S. Cl. D12/154

[58] Field of Search D12/154; 238/14

[56] References Cited

U.S. PATENT DOCUMENTS

- D. 196,773 10/1963 Carter D12/155
- D. 255,560 6/1980 La Pointe D12/154
- 4,361,277 11/1982 Cannady et al. 238/14

Primary Examiner—James M. Gandy

[57] CLAIM

The ornamental design for a tire anti-skid unit, as shown.

DESCRIPTION

FIG. 1 is a top perspective view of a tire anti-skid unit embodying my design;
 FIG. 2 is a bottom plan view thereof;
 FIG. 3 is a right side elevation view thereof;
 FIG. 4 is a front end elevation view thereof.

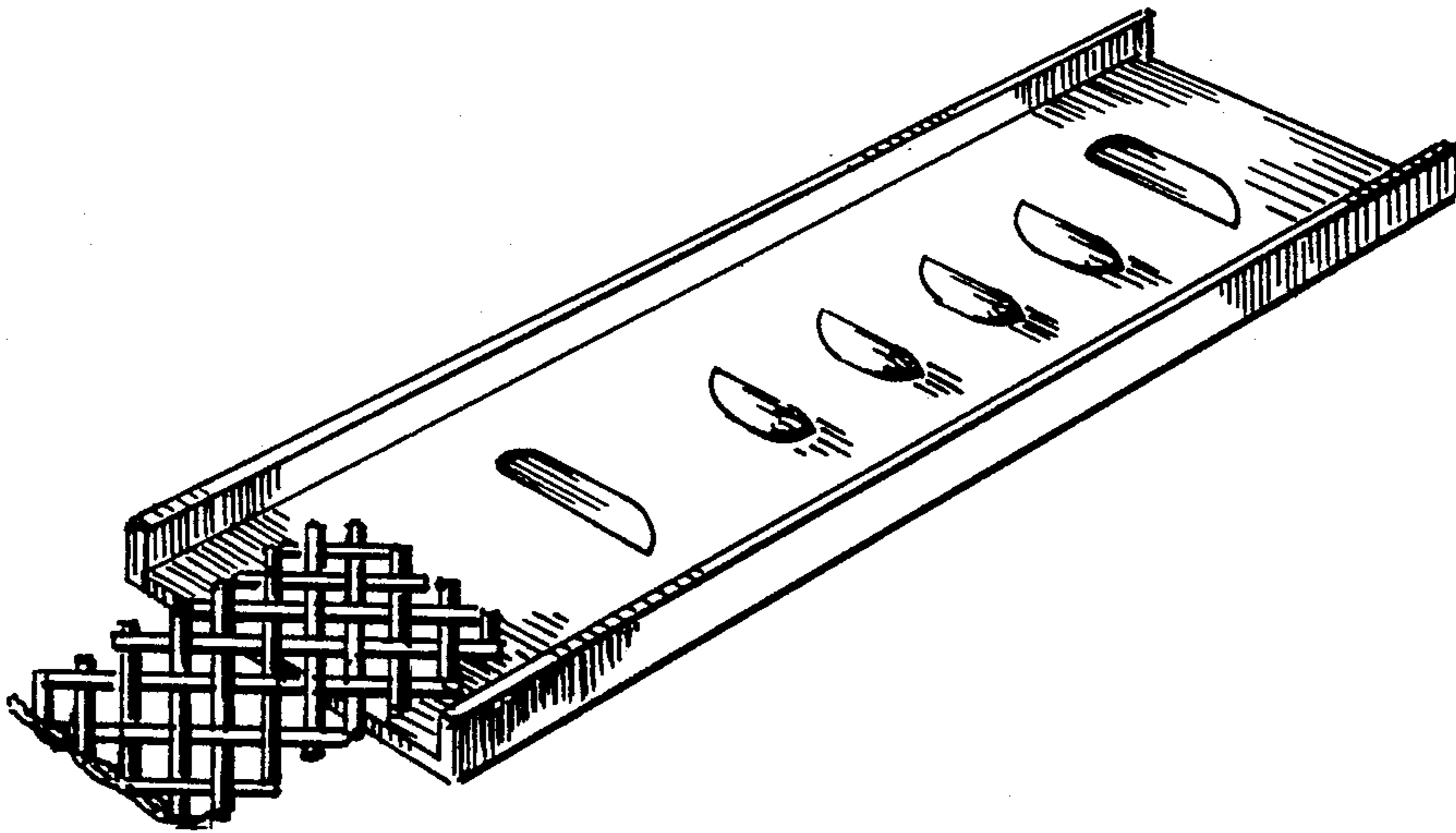

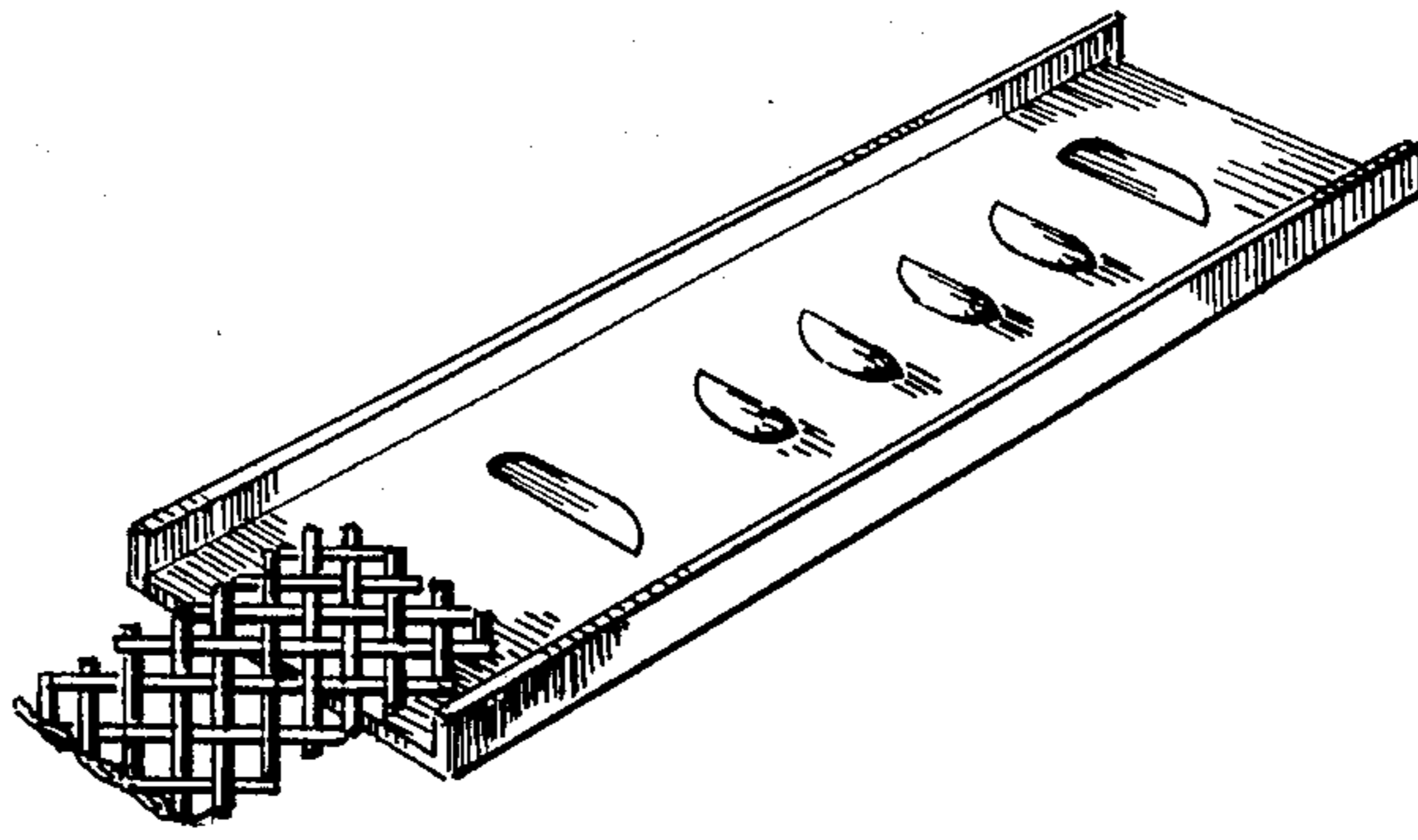

FIG. 1

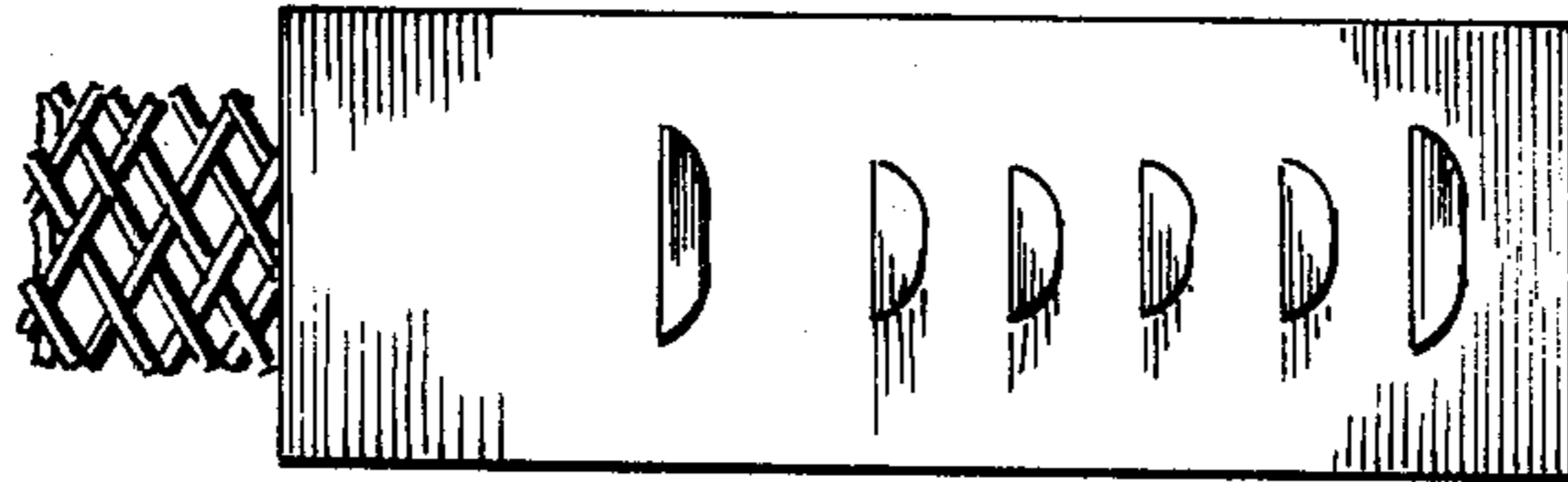

FIG. 2

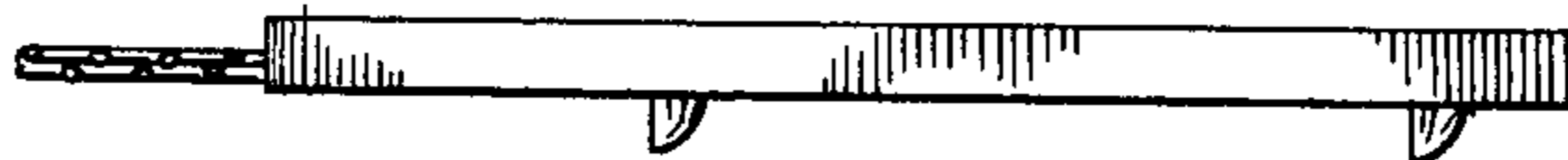

FIG. 3



FIG. 4