

United States Patent [19]

Anello et al.

[11] Patent Number: **Des. 301,191**

[45] Date of Patent: **** May 23, 1989**

[54] **FOLDABLE SEAT FOR USE PRIMARILY IN A CANOE**

[75] Inventors: **John R. Anello, Crown Point; James H. Hock, Putnam; Preston Mitchell, Mineville, all of N.Y.**

[73] Assignee: **Essex Industries, Mineville, N.Y.**

[**] Term: **14 Years**

[21] Appl. No.: **917,816**

[22] Filed: **Oct. 10, 1986**

[52] U.S. Cl. **D6/502**

[58] Field of Search **D6/362, 333, 379, 380, D6/367, 368; 297/250, 252; D12/317**

[56] **References Cited**

U.S. PATENT DOCUMENTS

D. 77,663 2/1929 Aldrich et al. D6/368
D. 203,169 12/1965 Collier D6/333
820,125 5/1906 Pennington 297/250

1,236,316 8/1917 Kelly 297/250
2,702,076 2/1955 Beardsley et al. 297/252
2,957,515 10/1960 Gibson 297/252
3,994,529 11/1976 Lippert 297/252

Primary Examiner—Bruce W. Duikins
Assistant Examiner—A. S. Hunt
Attorney, Agent, or Firm—Thomas N. Neiman

[57] **CLAIM**

The ornamental design for a foldable seat for use primarily in a canoe, as shown and described.

DESCRIPTION

FIG. 1 is a perspective view of the foldable seat for use primarily in a canoe showing my design; FIG. 2 is a front elevational view thereof; FIG. 3 is a rear elevational view; FIG. 4 is a side elevational view thereof; FIG. 5 is a top view; FIG. 6 is a bottom view thereof; and FIG. 7 is a perspective view of the foldable seat for use primarily in a canoe in the folded position.

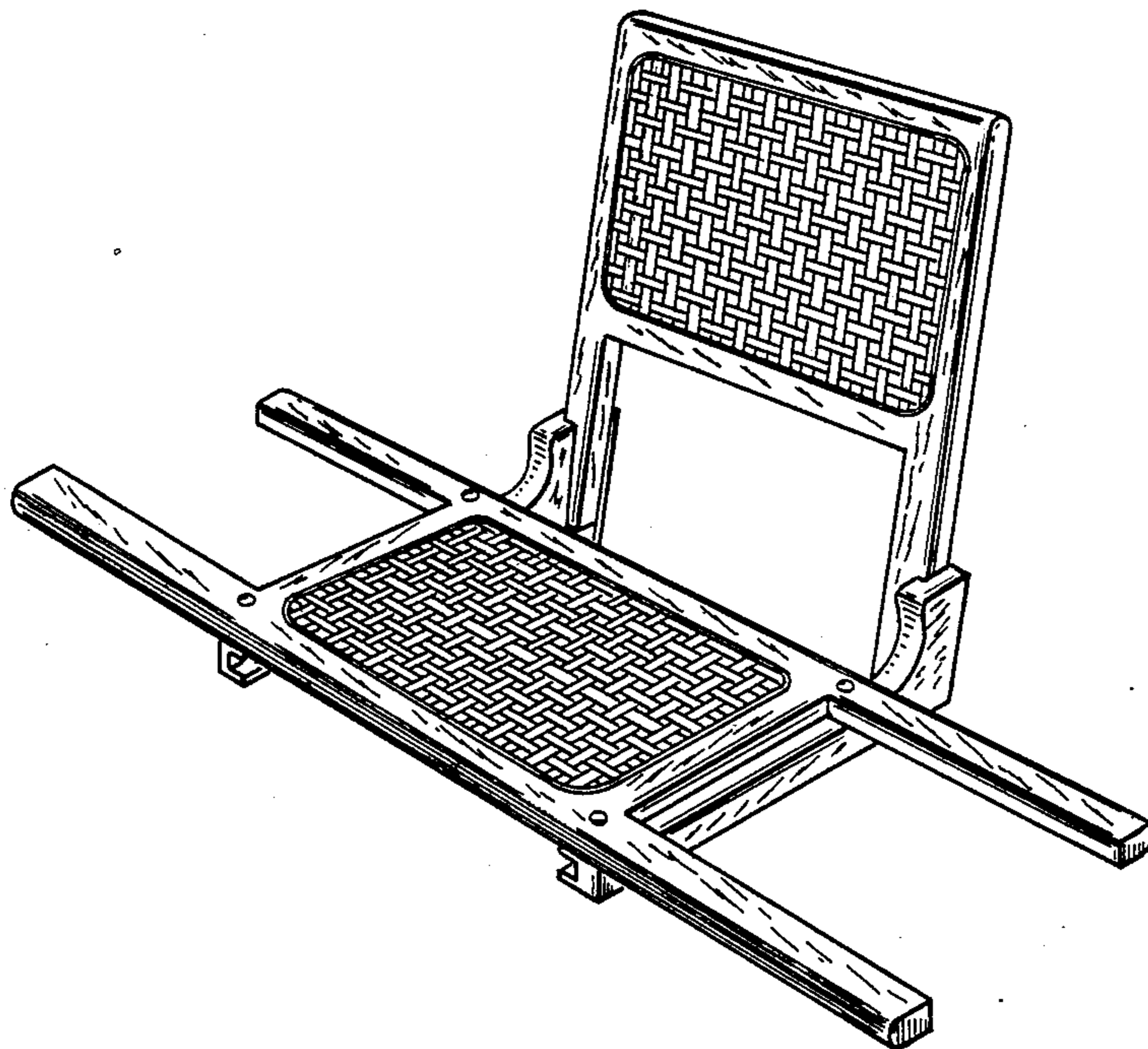

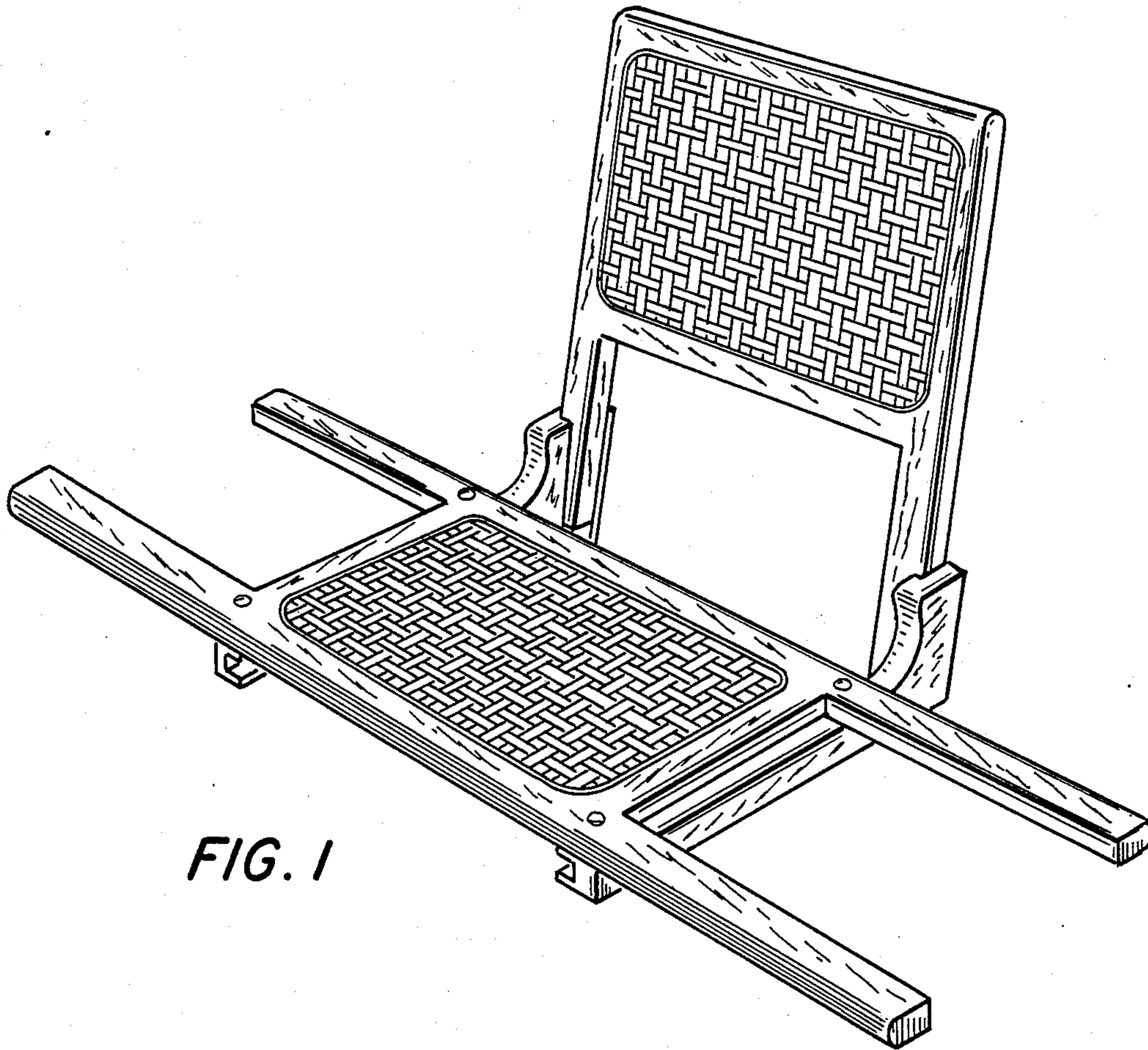

FIG. 1

FIG. 2

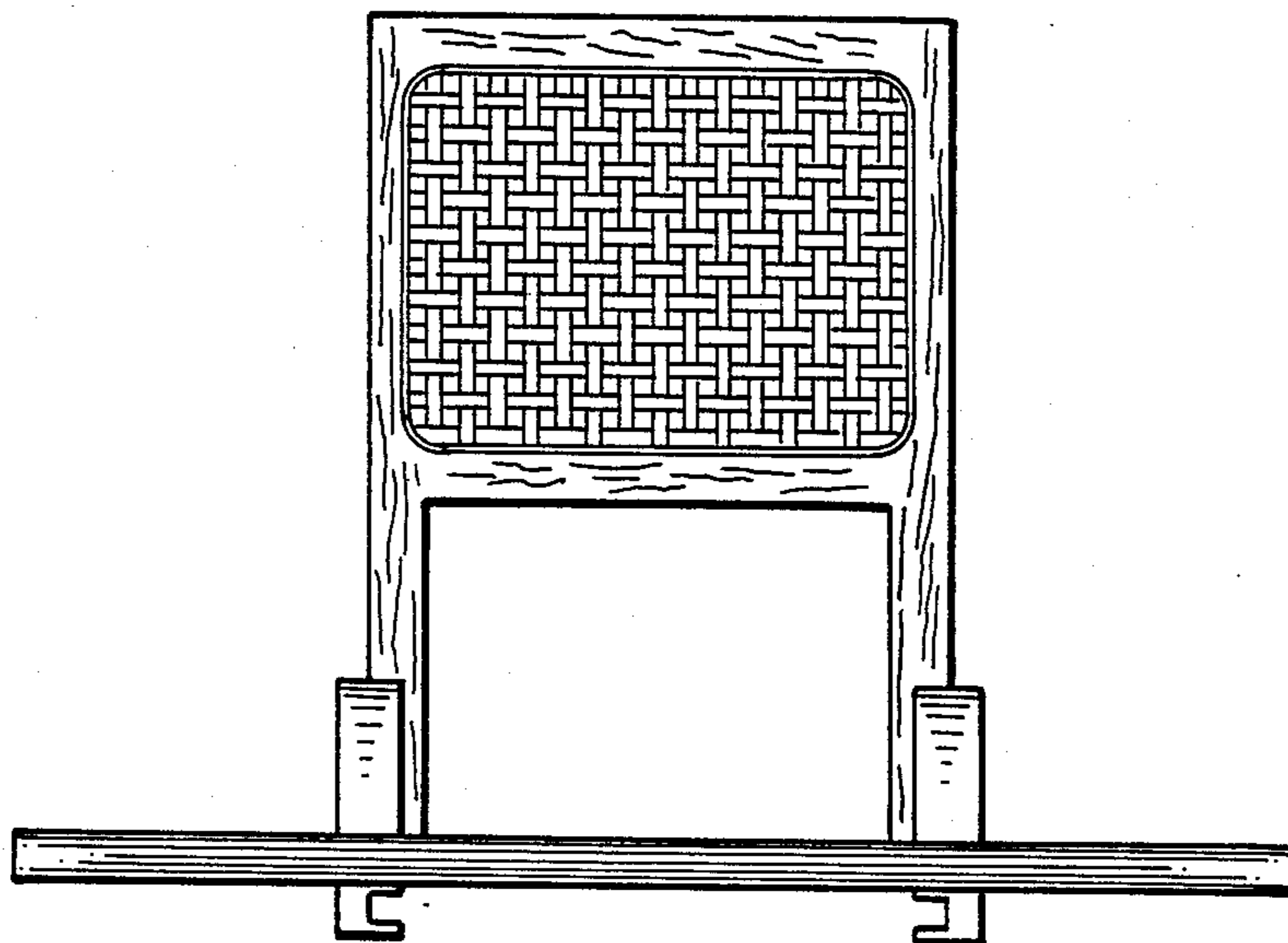

FIG. 3

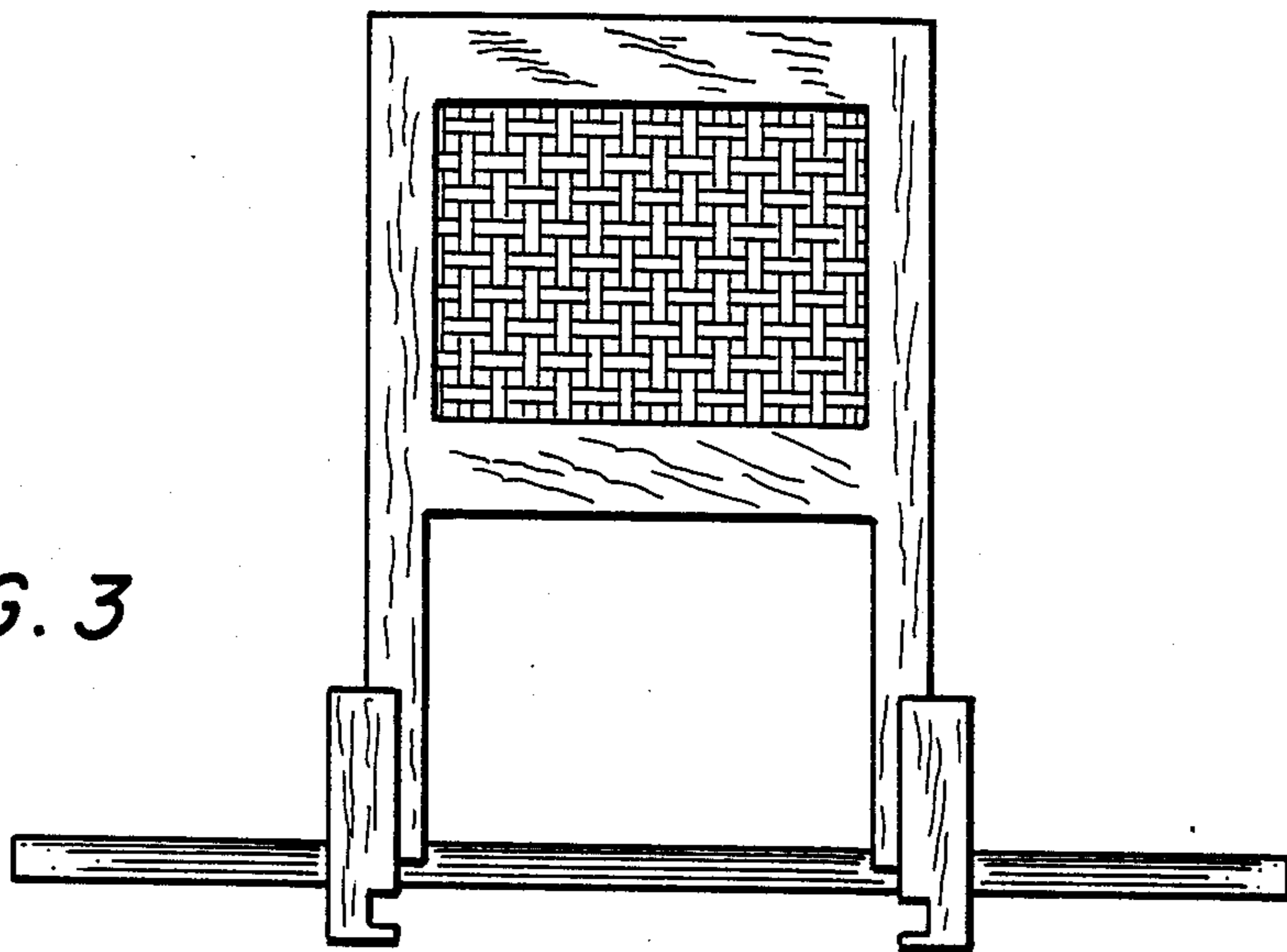

FIG. 4

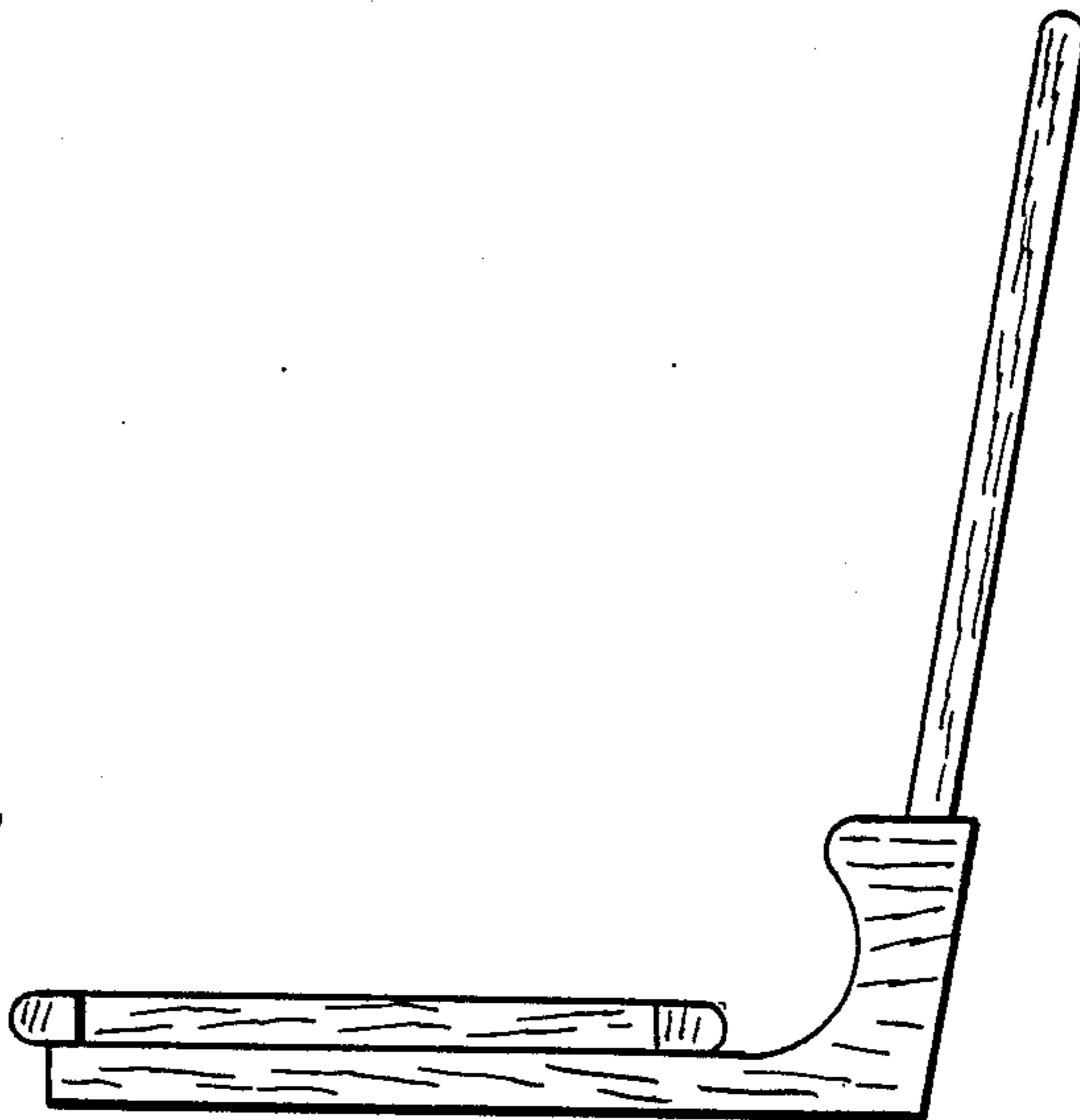
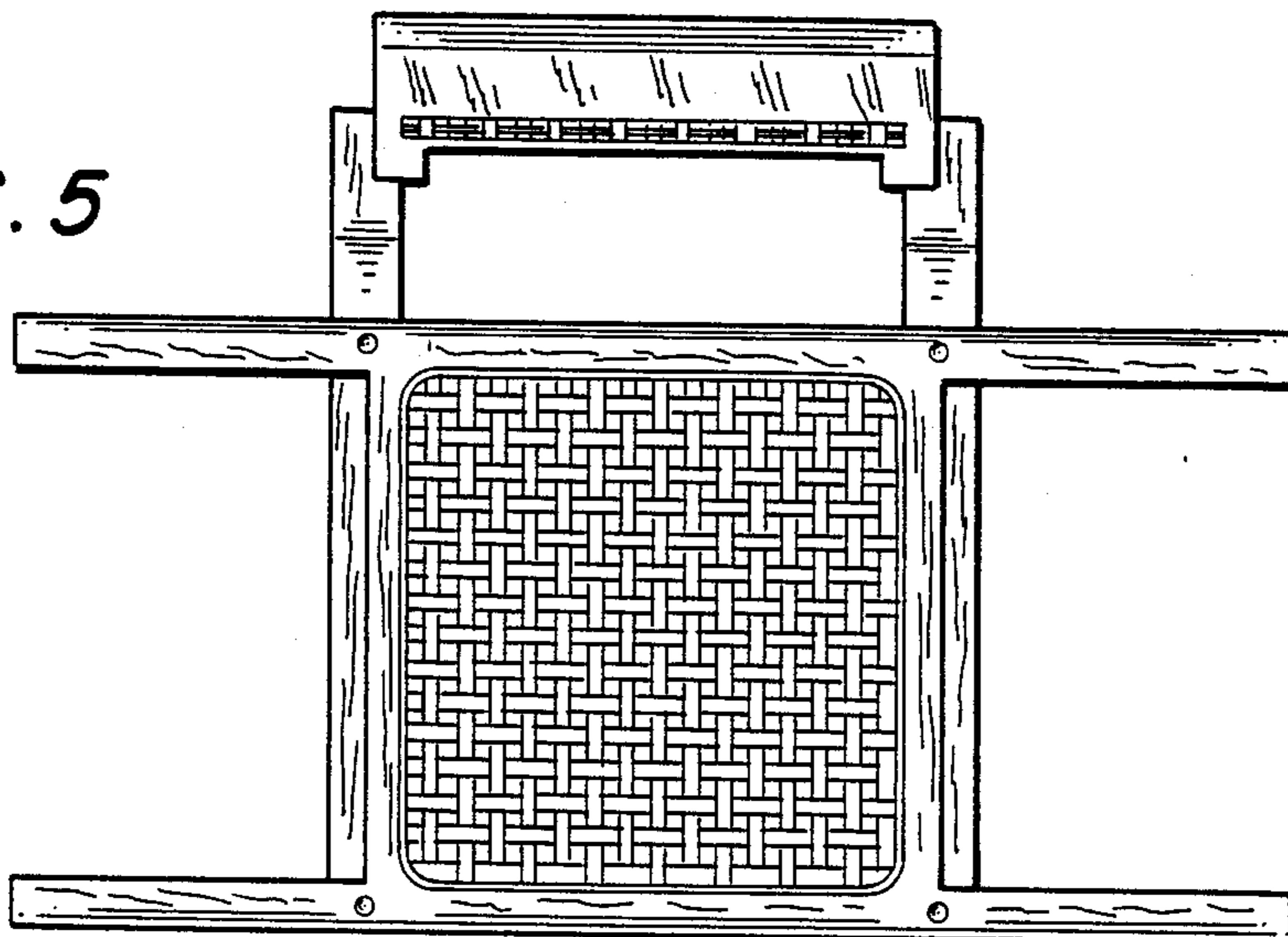

FIG. 5



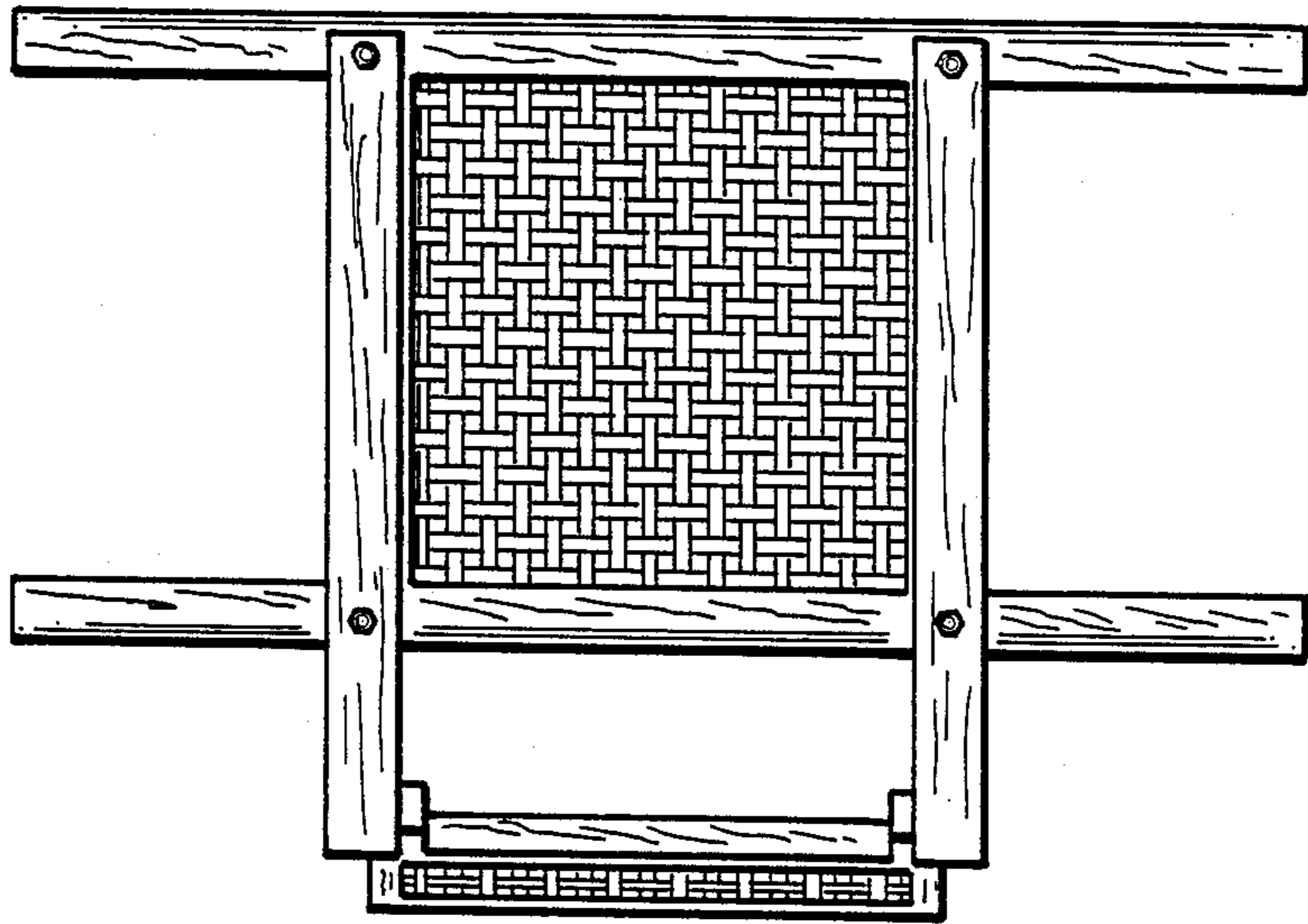

FIG. 6

FIG. 7

