

[54] WHEEL ALIGNMENT TEST STAND

[75] Inventor: John S. Norman, Waukegan, Ill.

[73] Assignee: Ammco Tools, Inc., North Chicago, Ill.

[**] Term: 14 Years

[21] Appl. No.: 874,527

[22] Filed: Jun. 16, 1986

[52] U.S. Cl. D34/21

[58] Field of Search D34/17, 21, 22; D10/46, D10/65; 280/79.3, 79.1 R

[56] References Cited

U.S. PATENT DOCUMENTS

- D. 224,096 7/1972 Propst et al. D34/17
- D. 237,700 11/1975 Clarke et al. D34/21

- D. 285,377 8/1986 Tanner D34/21
- 3,575,440 4/1971 Lay 280/79.3
- 4,679,805 7/1987 Cunningham 280/79.3
- 4,753,356 6/1988 Nootenboom et al. 280/79.3

Primary Examiner—B. J. Bullock
 Assistant Examiner—Dominic Simone
 Attorney, Agent, or Firm—Edmond T. Patnaude

[57] CLAIM

The ornamental design for a wheel alignment test stand, as shown and described.

DESCRIPTION

FIG. 1 is a front elevational view of a wheel alignment test stand showing my new design;
 FIG. 2 is a left side elevational view thereof;
 FIG. 3 is a rear elevational view thereof;
 FIG. 4 is a right side elevational view thereof; and
 FIG. 5 is a top plan view thereof.

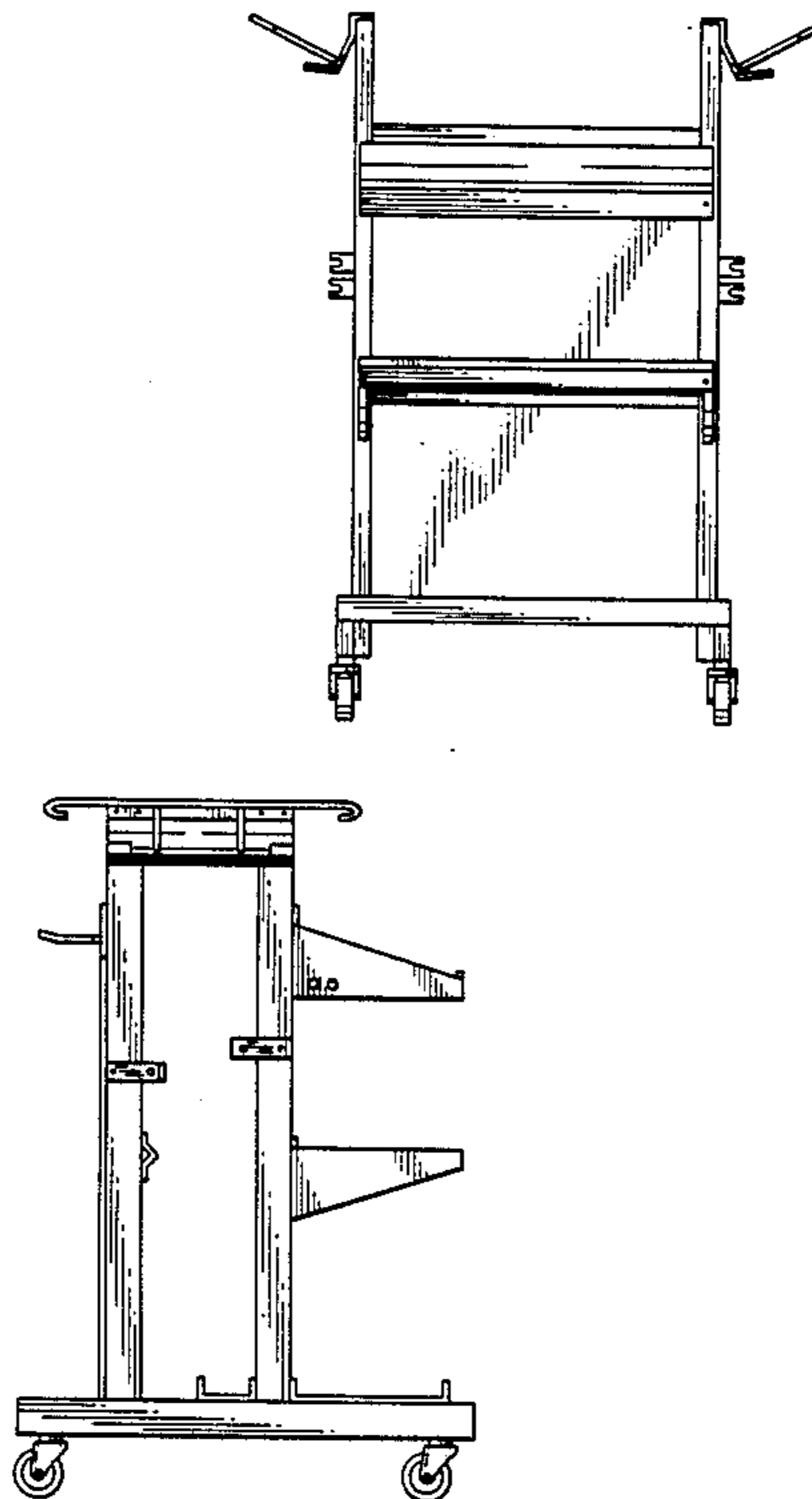

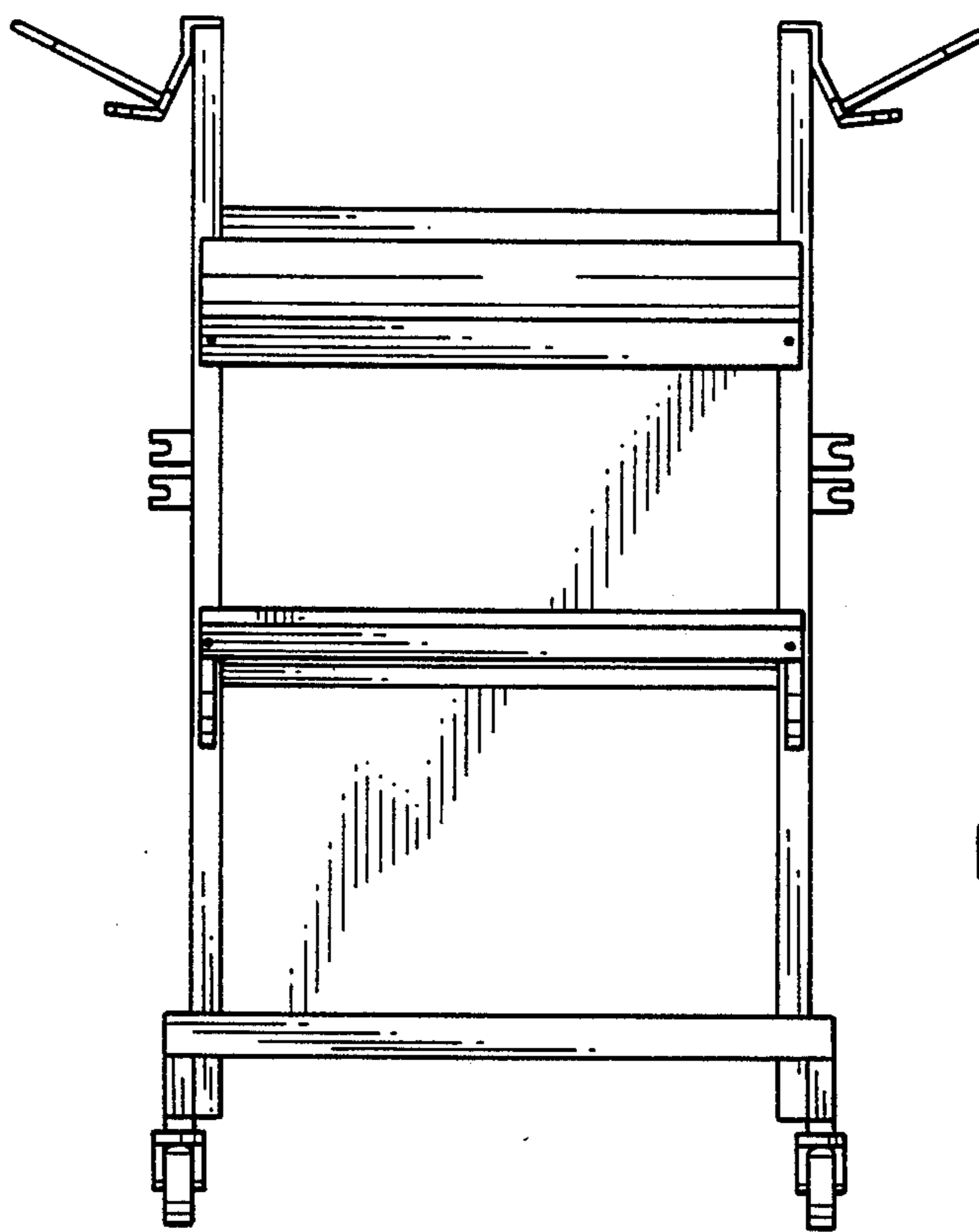

FIG. 1

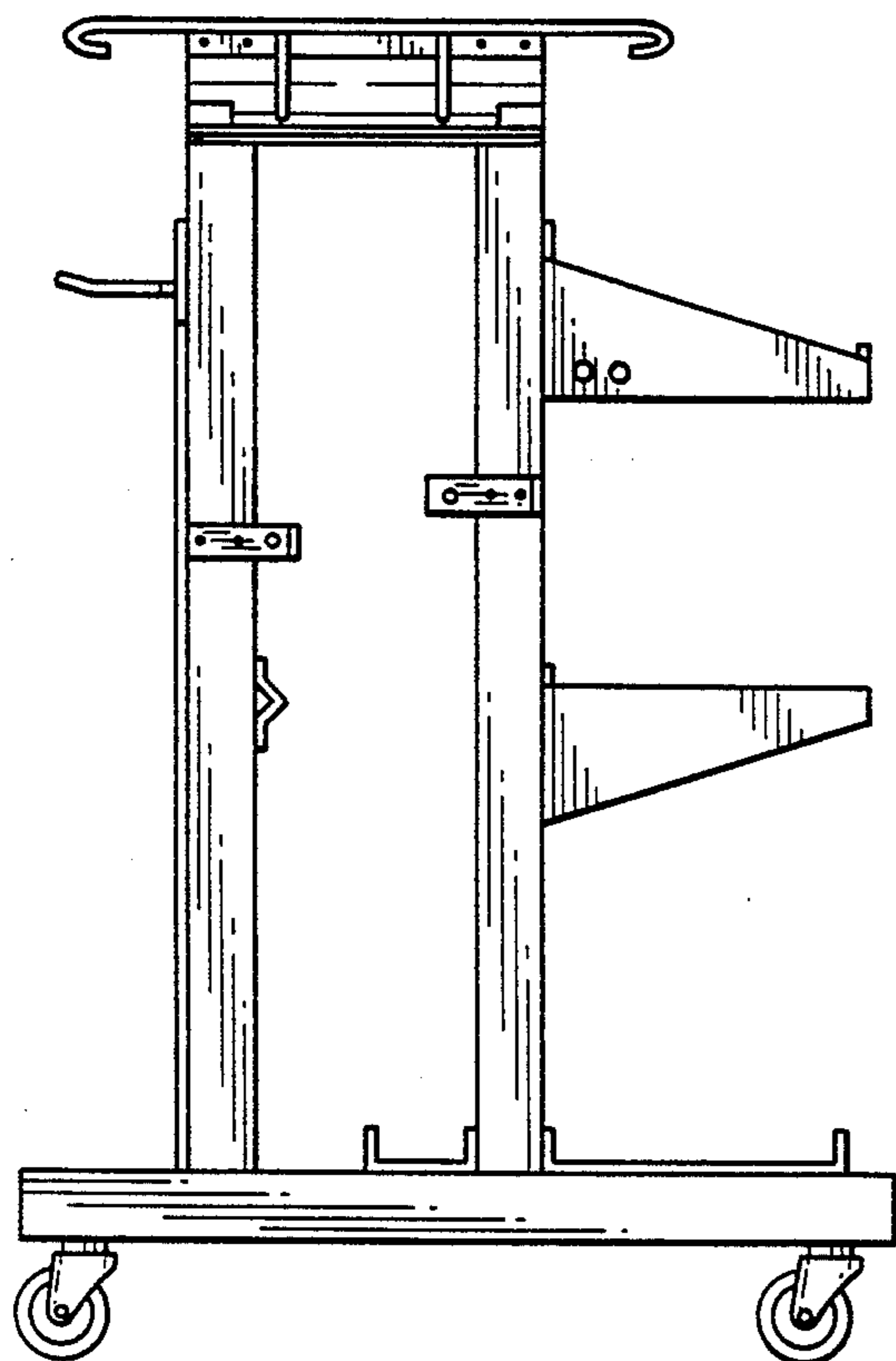

FIG. 2

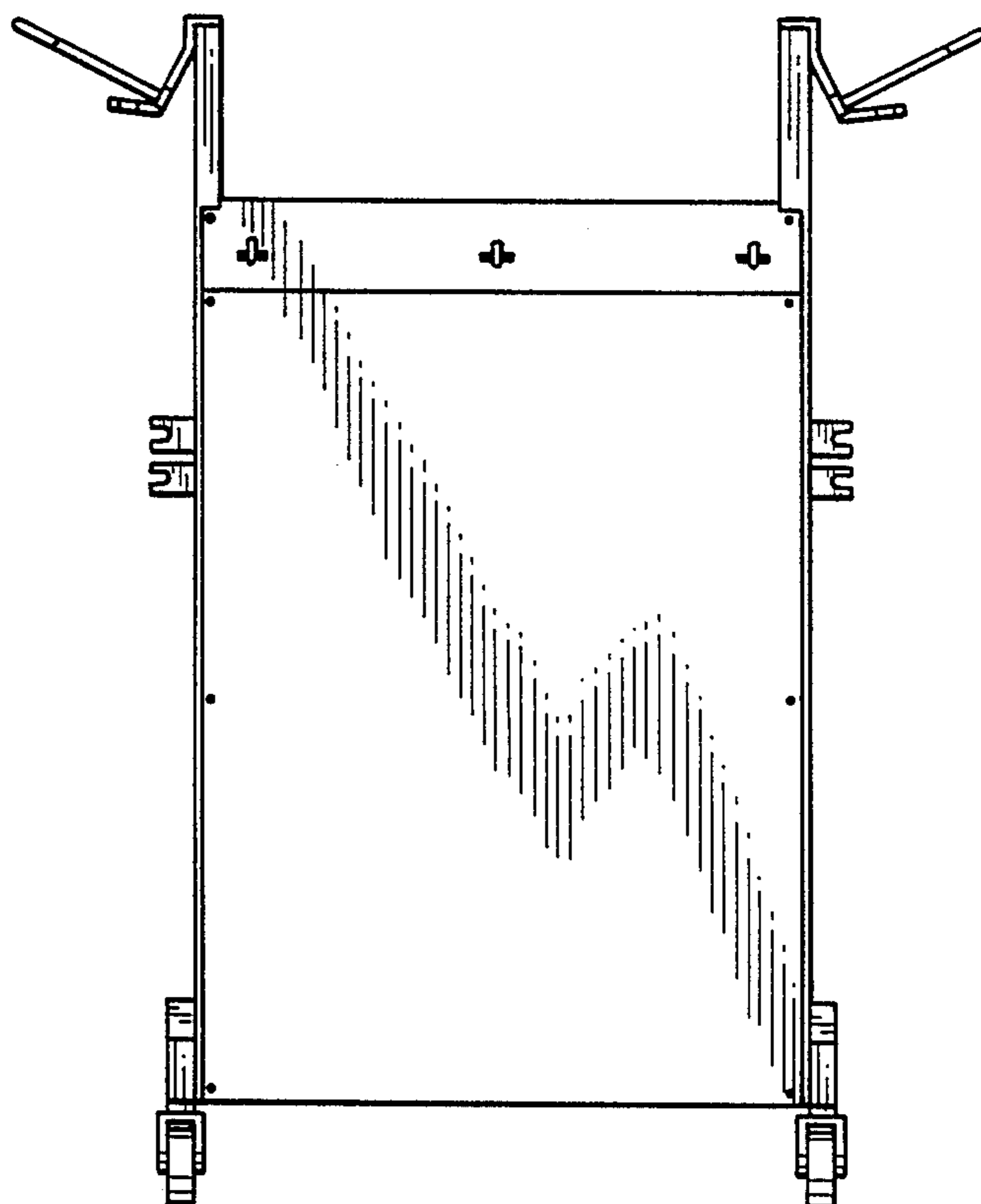

FIG. 3

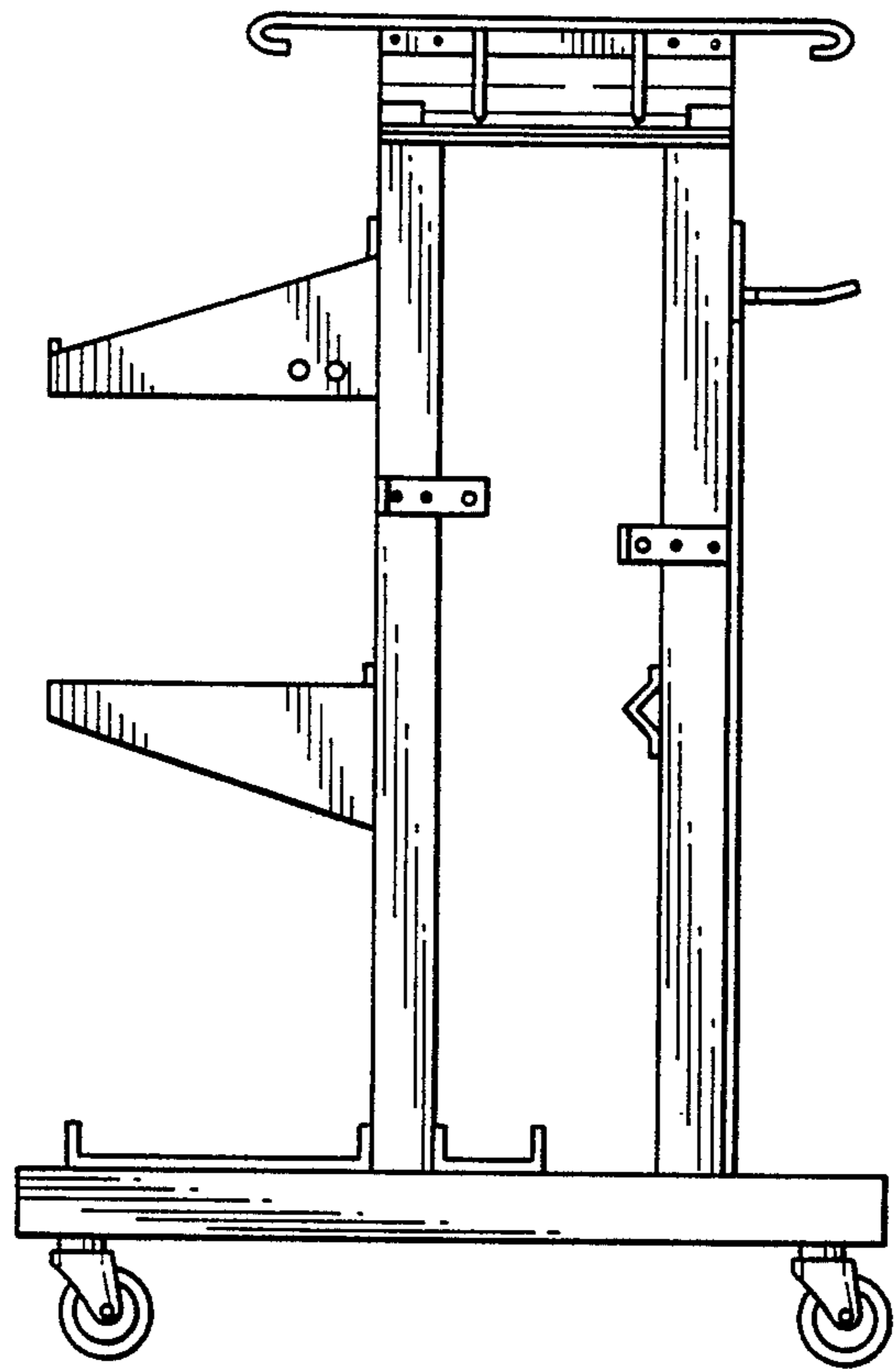

FIG. 4

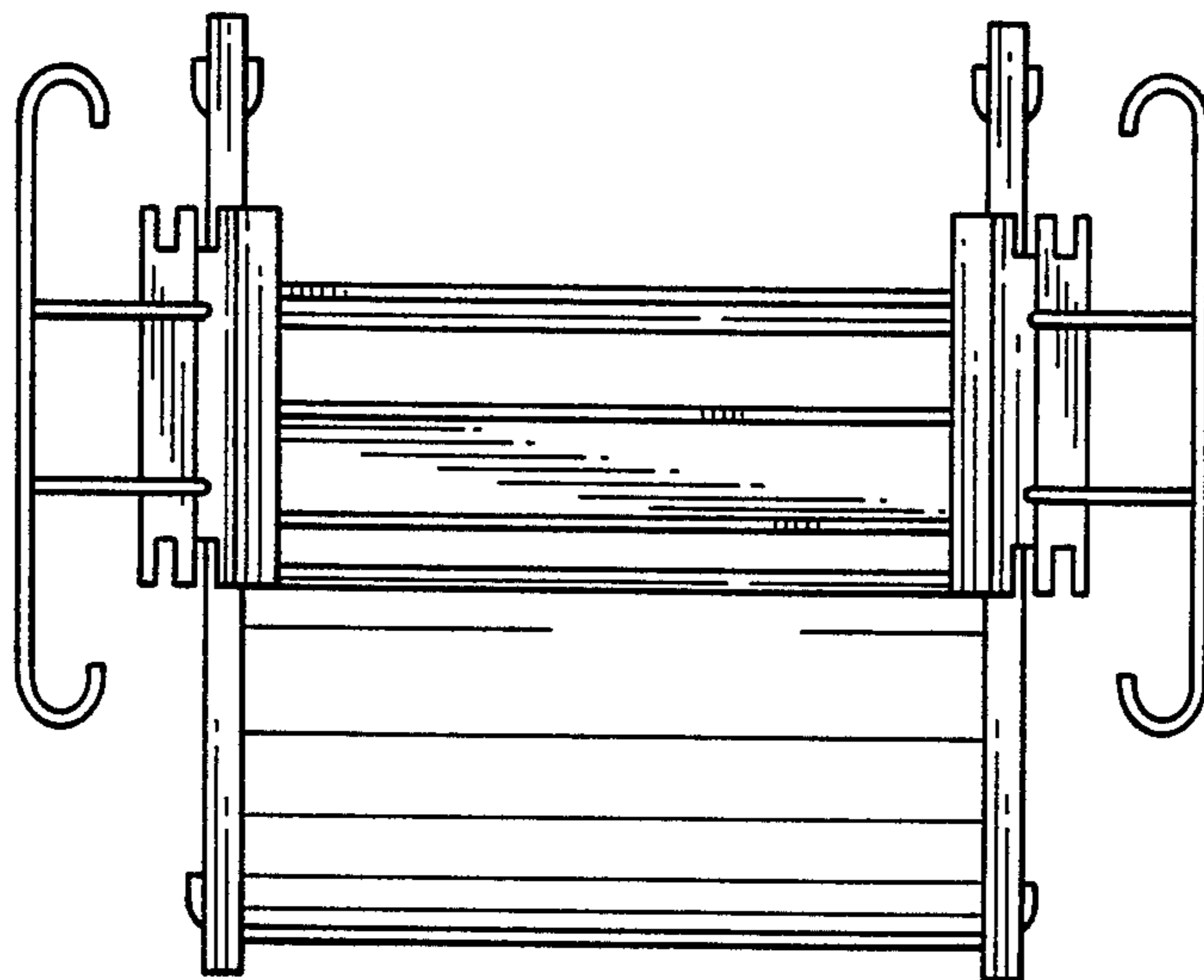

FIG. 5