

[54] LIGHT WEIGHT TRUCK RAIL

[76] Inventor: Timmy L. Ellison, 102 W. Church, Kenton, Tenn. 38233

[**] Term: 14 Years

[21] Appl. No.: 856,132

[22] Filed: Apr. 18, 1986

[52] U.S. Cl. D12/155

[58] Field of Search D12/155; D21/71; 296/3, 296/10, 43

[56] References Cited

U.S. PATENT DOCUMENTS

4,216,988	8/1980	Weiss	296/10
4,585,264	4/1986	Miller	296/3

OTHER PUBLICATIONS

1940 Montgomery Ward Catalog, p. 620, Rear Side Stake Rail of Chore Truck Wagon, top left side of page.
1952 Sears Christmas Catalog, p. 285, Rear Side Stake of Roy Rogers Chuck Wagon, top left side of page.
1963 Sears Christmas Catalog, p. 102, Side Stake Rail of Stake Wagon, top left side of page.

Primary Examiner—James M. Gandy
Attorney, Agent, or Firm—Terry M. Gernstein

[57] CLAIM

The ornamental design for light weight truck rail, as shown.

DESCRIPTION

FIG. 1 is a perspective view of the rear and one side of a light weight truck rail showing my new design; FIG. 2 is a perspective view of the rear and opposite side thereof; FIG. 3 is a rear elevation view thereof; and FIG. 4 is a front elevation view thereof.

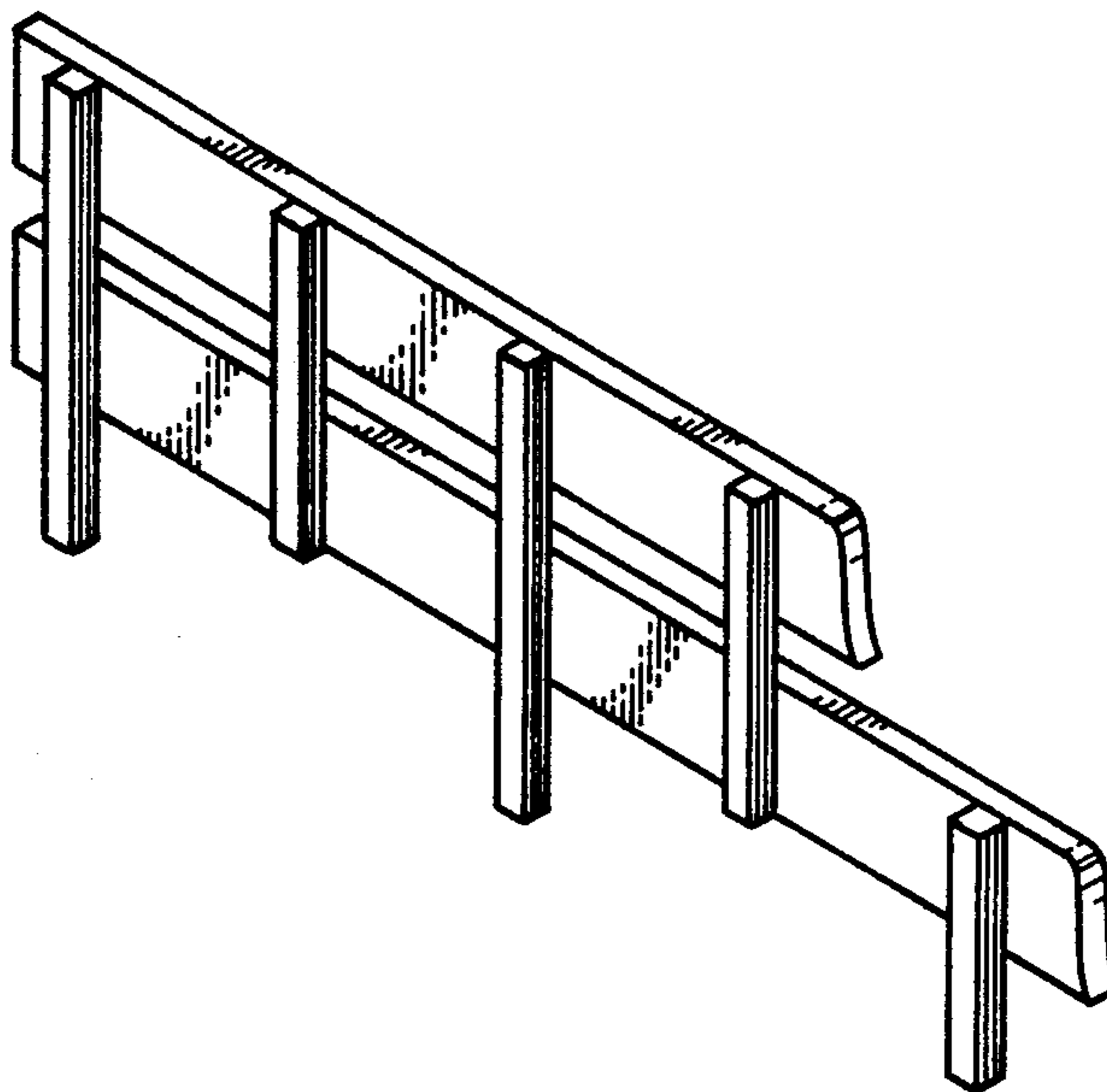

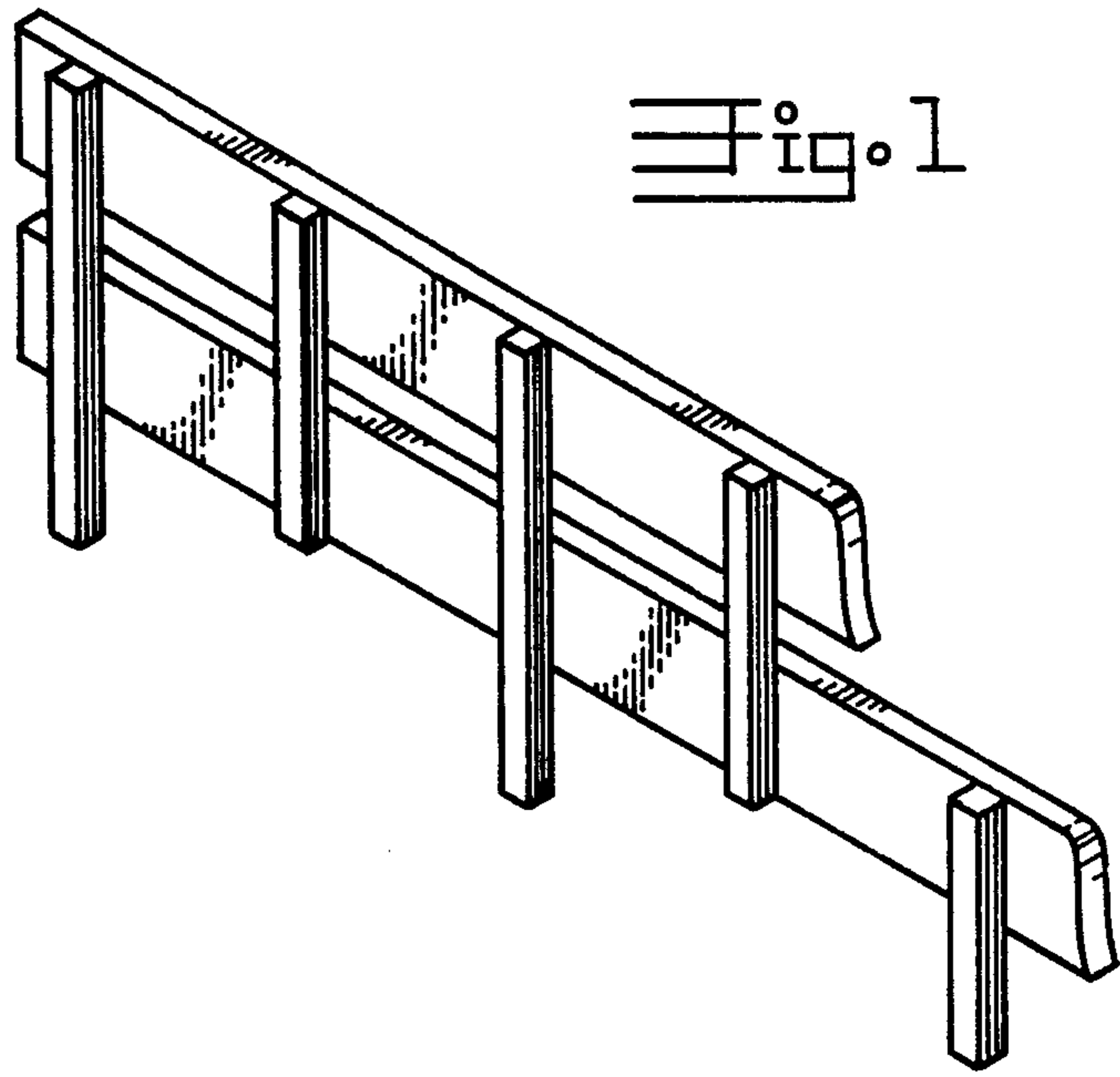

Fig. 1

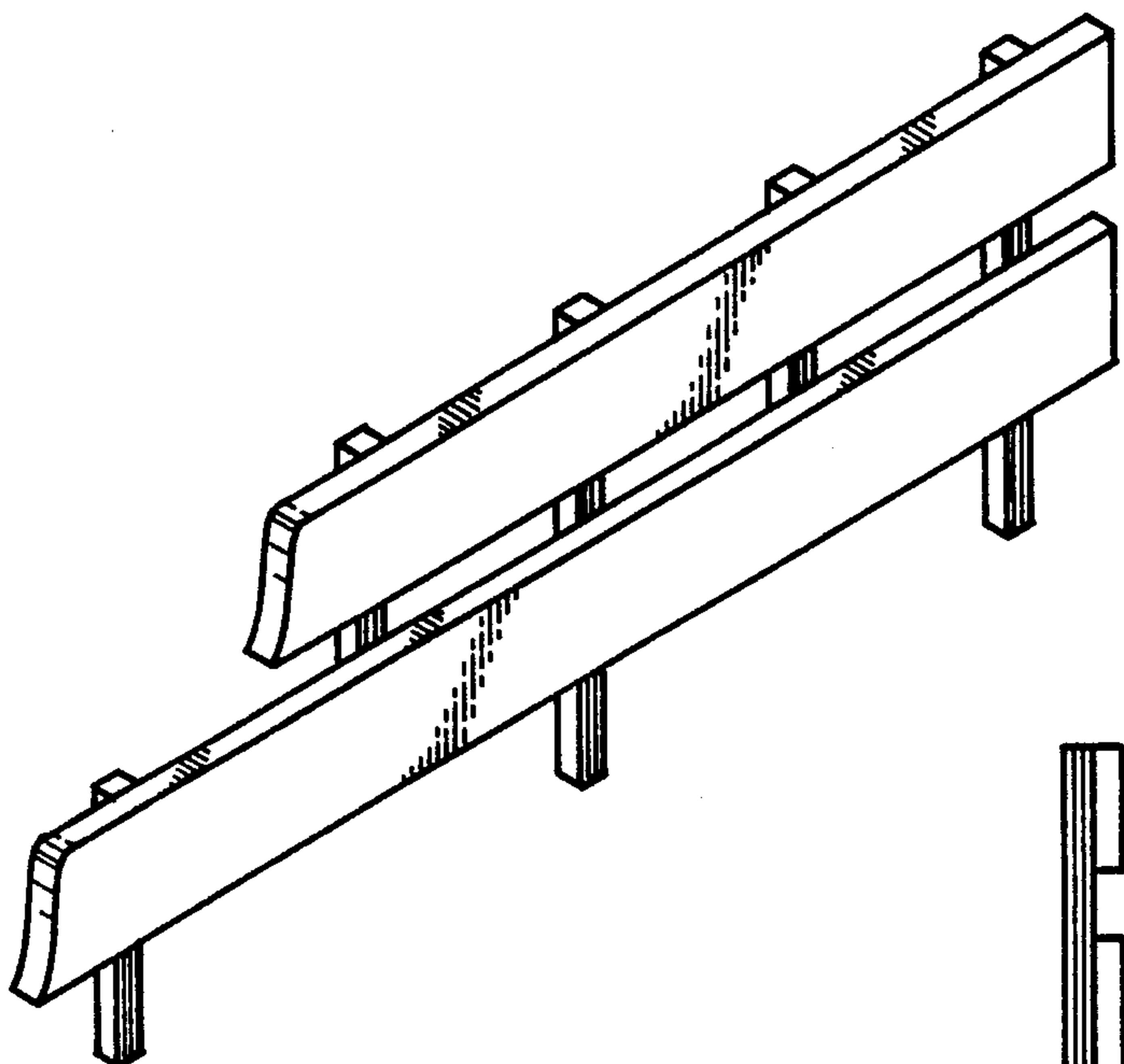

Fig. 2



Fig. 3



Fig. 4