

[54] **BOAT HULL**

[75] **Inventors:** Marley Duclo, Hotchkiss, Colo.;
Edward H. Webb, Paynesville;
Darwin L. Miller, Spicer, both of
Minn.

[73] **Assignee:** Wetjet International, Ltd.,
Paynesville, Minn.

[**] **Term:** 14 Years

[21] **Appl. No.:** 838,020

[22] **Filed:** Feb. 28, 1986

[52] **U.S. Cl.** D12/312; D12/307

[58] **Field of Search** D12/300, 306, 307, 305,
D12/312; 114/56, 289-291, 270; 440/38, 87, 88,
89, 85; D21/228, 236, 229

[56] **References Cited**

U.S. PATENT DOCUMENTS

- D. 226,239 1/1973 Varner D12/312
- D. 252,140 6/1979 Pelkey D12/312
- 3,191,572 6/1965 Wilson 440/38

- 3,290,706 12/1966 Hale D12/317
- 3,702,106 11/1972 Wilder 114/270

FOREIGN PATENT DOCUMENTS

- 1455402 9/1965 France 114/270

Primary Examiner—Wallace R. Burke
Assistant Examiner—Kay H. Chin
Attorney, Agent, or Firm—Merchant, Gould, Smith,
Edell, Welter & Schmidt

[57] **CLAIM**

The ornamental design for a boat hull, as shown and described.

DESCRIPTION

FIG. 1 is a perspective view of a boat hull showing our new design;
FIG. 2 is a front elevational view thereof;
FIG. 3 is a rear elevational view thereof;
FIG. 4 is a side elevational view thereof, the opposite side elevational view being a mirror image of that shown;
FIG. 5 is a top plan view thereof; and
FIG. 6 is a bottom plan view thereof.

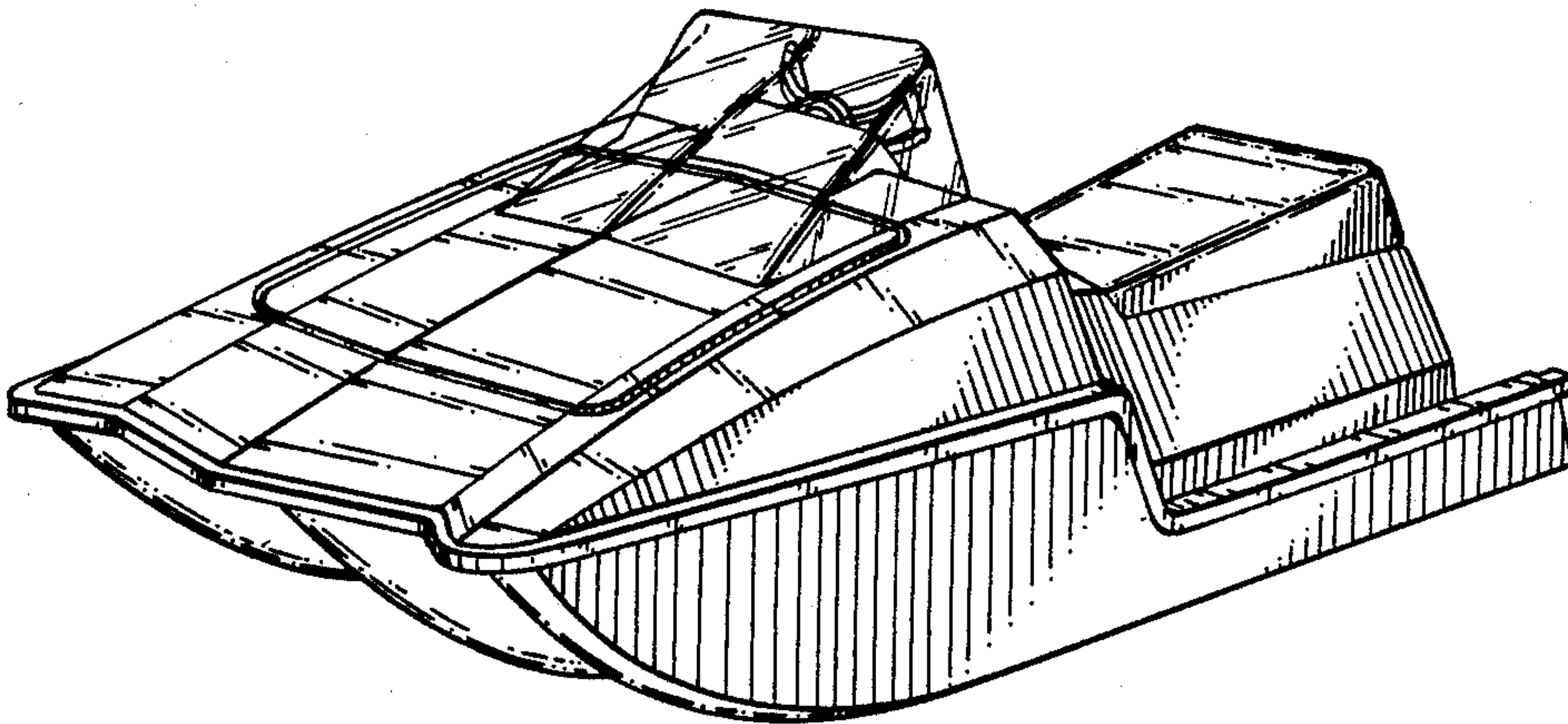

FIG. 1

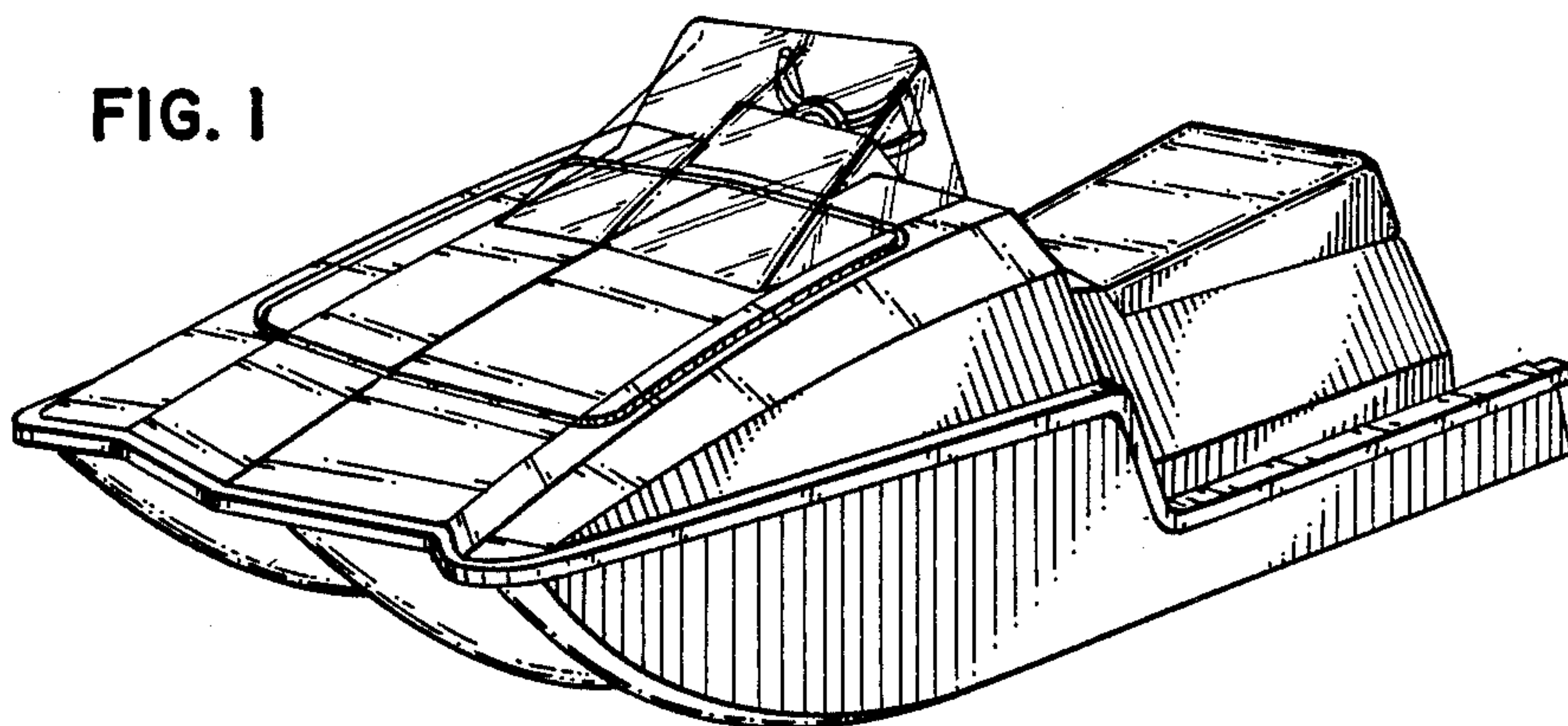

FIG. 2

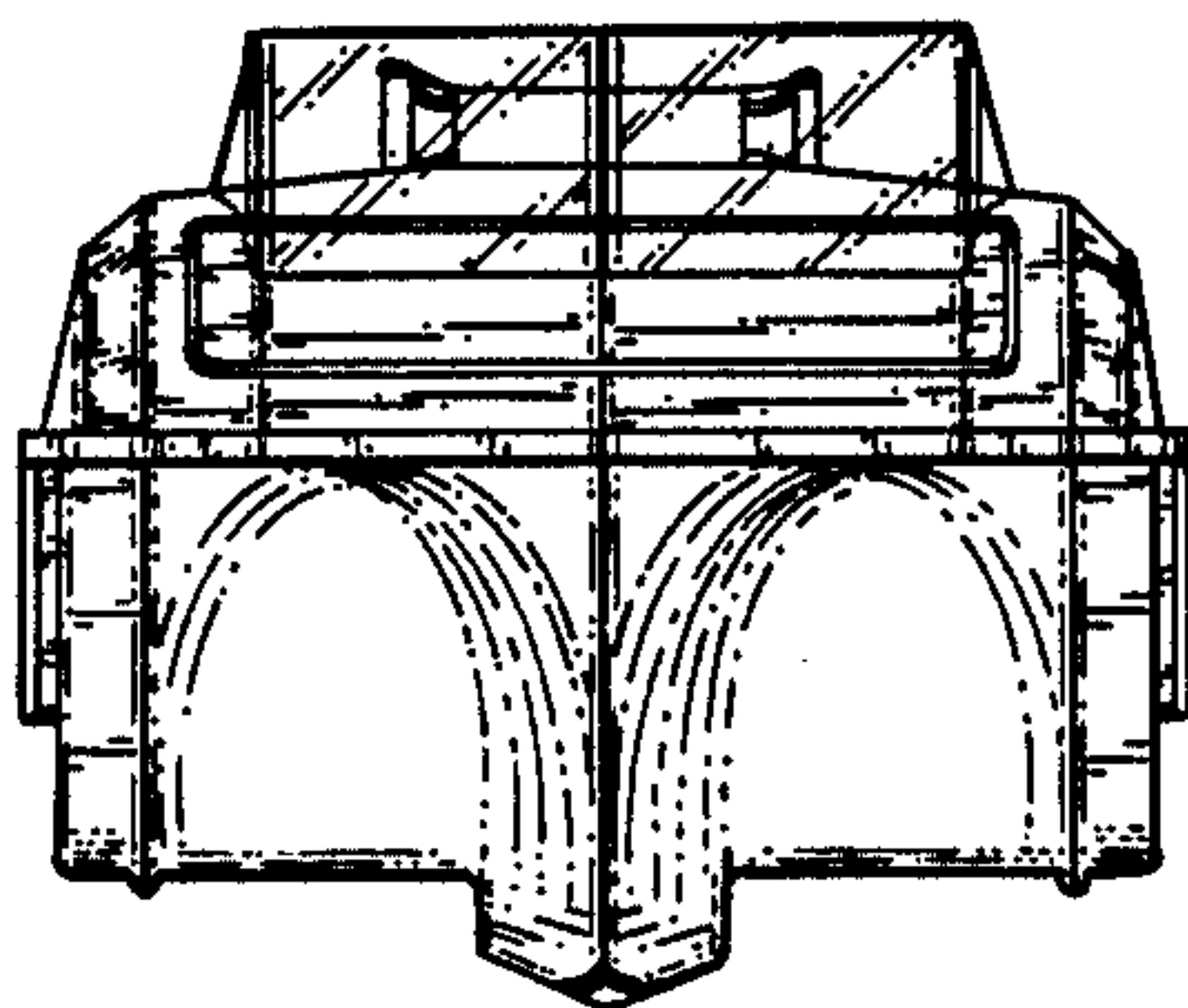

FIG. 3

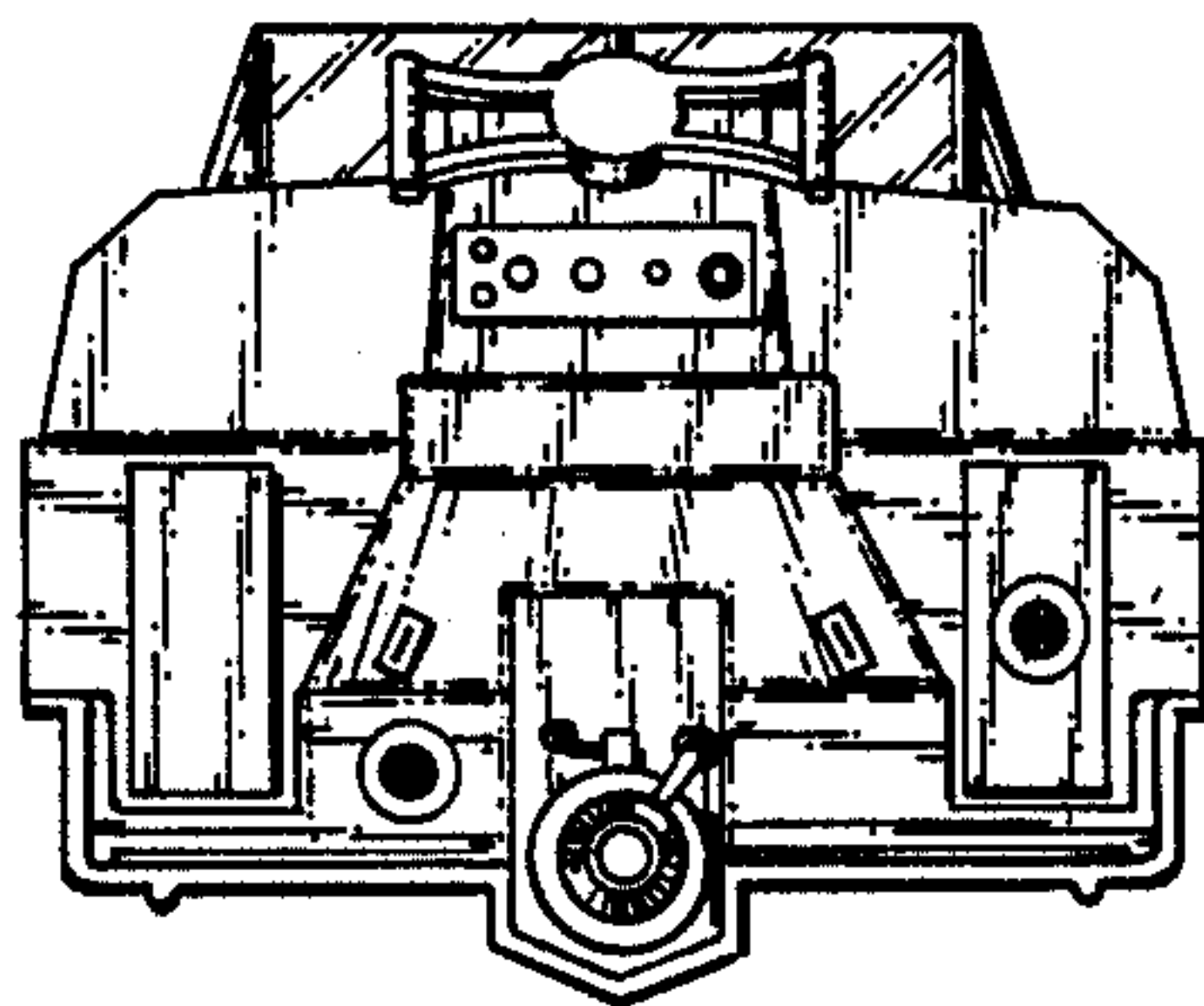

FIG. 4

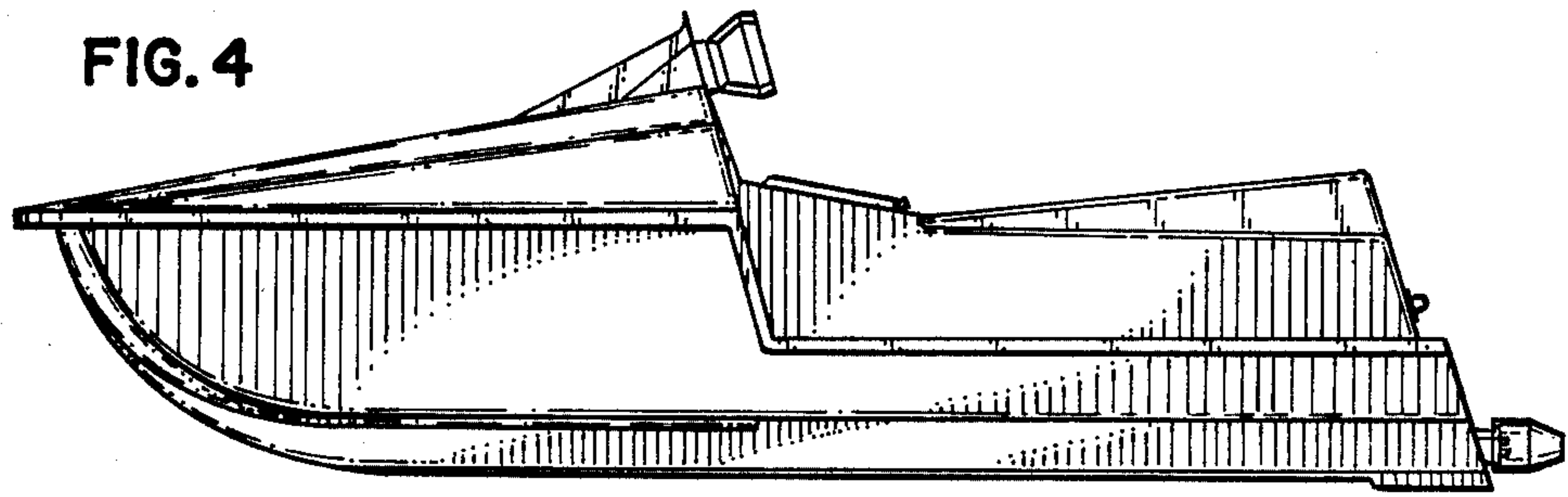

FIG. 5

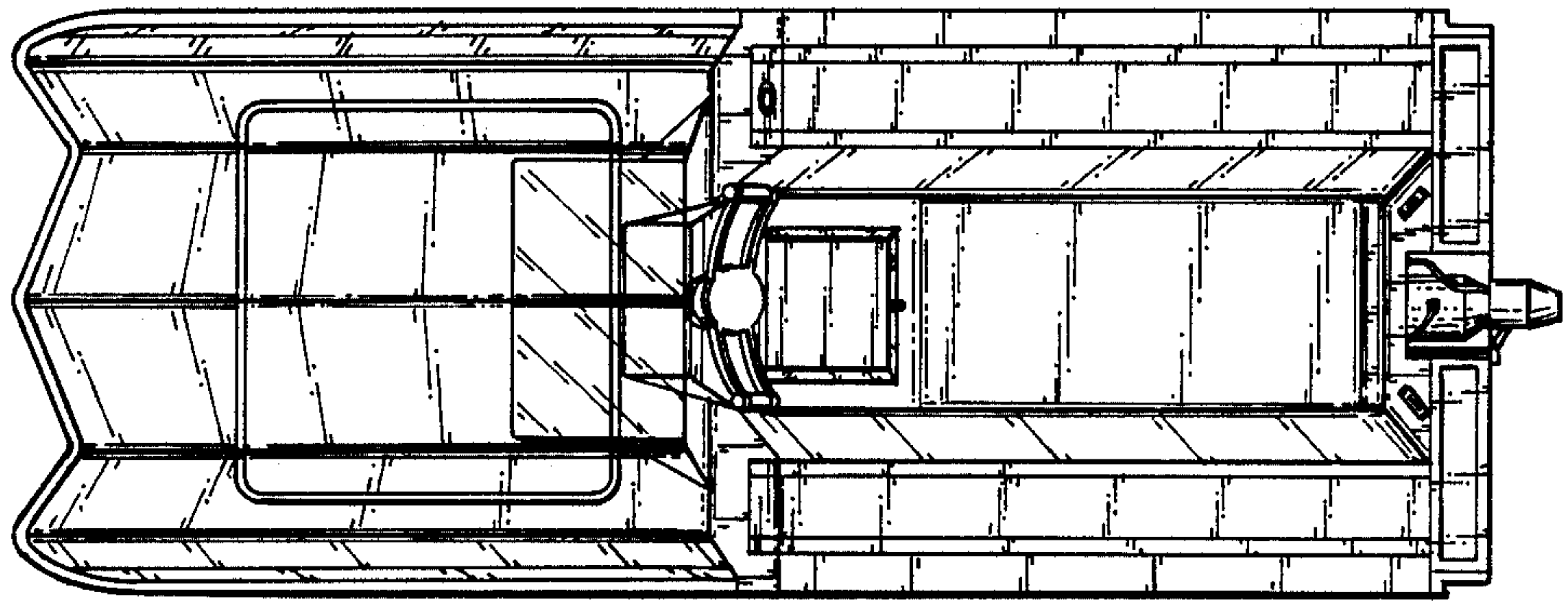

FIG. 6

