

[54] **VEHICLE TIRE**

[75] **Inventors: Hubert Grohman; Halvard Nilsson,**
both of Gislaved, Sweden

[73] **Assignee: Gislaved Aktiebolag, Gislaved,**
Sweden

[**] **Term: 14 Years**

[21] **Appl. No.: 930,385**

[22] **Filed: Nov. 13, 1986**

[30] **Foreign Application Priority Data**

Jun. 4, 1986 [SE] Sweden 86-1353

[52] **U.S. Cl. D12/147**

[58] **Field of Search D12/140-143,**
D12/145-151; 152/209 R, 209 D, 209 B

[56] **References Cited**

U.S. PATENT DOCUMENTS

D. 283,996 5/1986 Kuramochi et al. D12/140

D. 295,162 4/1988 Nilsson et al. D12/147

OTHER PUBLICATIONS

Tire Service Station, 12/47, p. 60, Tire, top right side of page.

Tire Review, 5/85, p. 86, Pirelli H-rated P600 Tire, top center of page.

Tire Review, 4/86, p. 90, Dunlop G/T Qualifier, center of page.

Primary Examiner—James M. Gandy
Attorney, Agent, or Firm—Frishauf, Holtz, Goodman & Woodward

[57] **CLAIM**

The ornamental design for a vehicle tire, as shown and described.

DESCRIPTION

FIG. 1 is a front elevational view of a vehicle tire showing our new design it being understood that the tread pattern is repeated throughout the circumference of the tire as shown schematically by solid lines, and the opposite side is the same as the side shown; and FIG. 2 is a perspective view thereof.

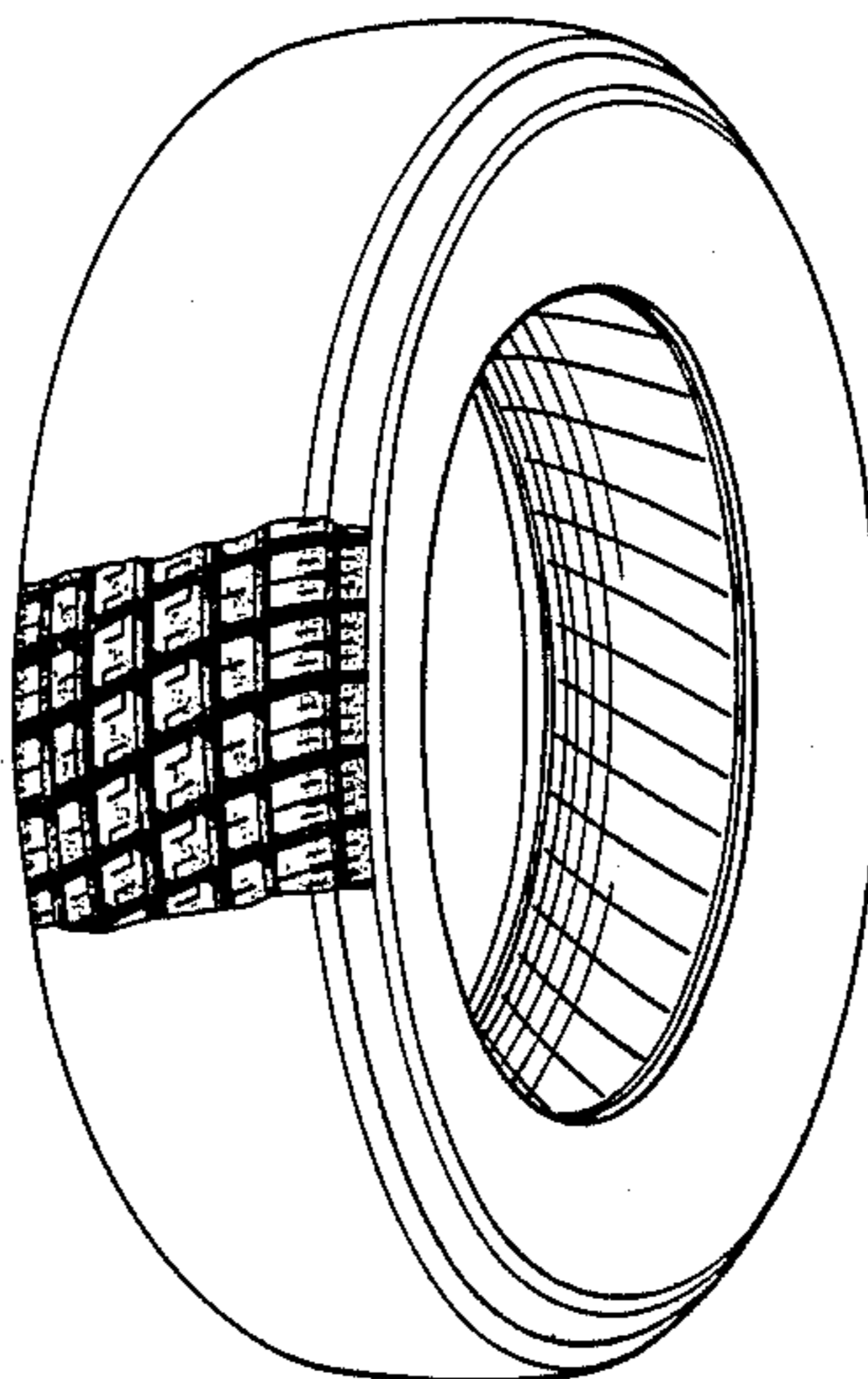

FIG. 1

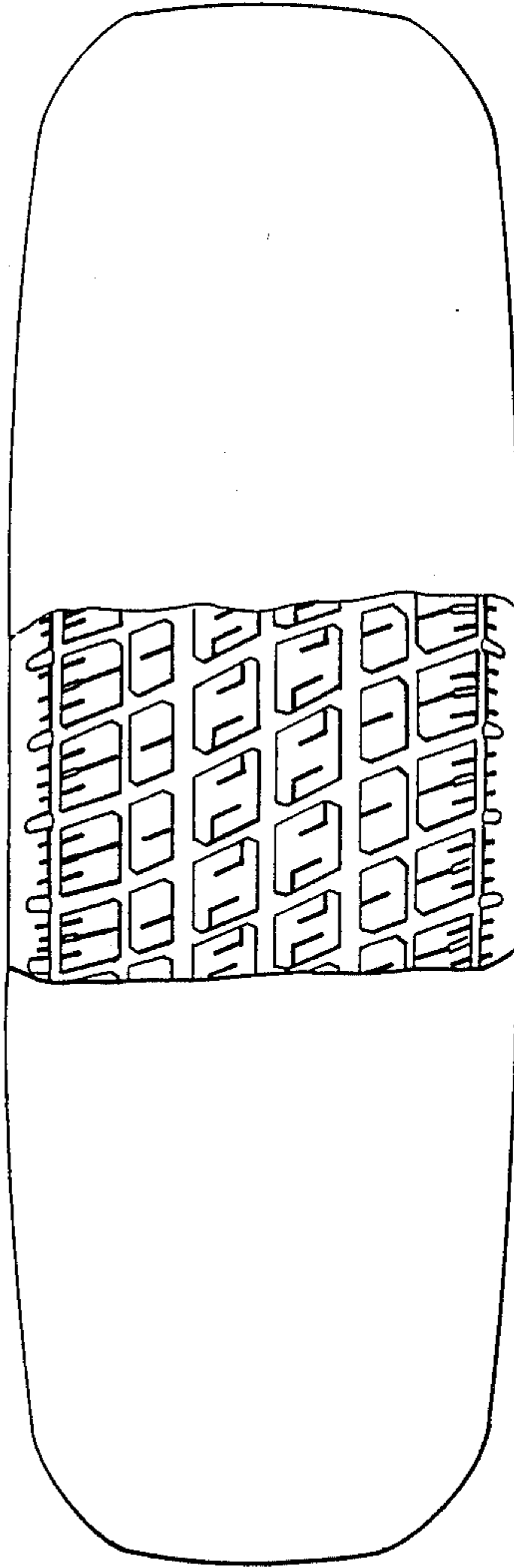

Fig. 2

