

[54] GAS PRESSURE MEASURING AND DATA TRANSMITTING DEVICE

[75] Inventor: John Hestich, Glendora, Calif.

[73] Assignee: Dwyer Instruments, Inc., Michigan City, Ind.

[**] Term: 14 Years

[21] Appl. No.: 850,410

[22] Filed: Apr. 7, 1986

[52] U.S. Cl. D10/85; D10/103

[58] Field of Search D10/85, 94, 102-103;
73/431, 756, 722

[56] References Cited

U.S. PATENT DOCUMENTS

D. 291,231	8/1987	Datta	D10/85 X
3,277,719	10/1966	Prell	73/722
3,526,136	9/1970	Caldwell	73/756
3,564,923	2/1971	Nudd	73/722 X
3,842,679	10/1974	Iwao	73/431 X

Primary Examiner—Nelson C. Holtje
Attorney, Agent, or Firm—Mann, McWilliams, Zummer & Sweeney

[57] CLAIM

The ornamental design for gas pressure measuring and data transmitting device, as shown and described.

DESCRIPTION

FIG. 1 is a top and right front perspective view of a Gas Pressure Measuring And Data Transmitting Device showing my new design;

FIG. 2 is a front elevational view thereof;

FIG. 3 is a bottom plan view thereof;

FIG. 4 is an inverted rear elevational view thereof;

FIG. 5 is a top plan view thereof rotated 180°;

FIG. 6 is a left side elevational view thereof;

FIG. 7 is a right side elevational view thereof;

FIG. 8 is a top and right front perspective view of another embodiment of my new design of FIGS. 1-7;

FIG. 9 is a front elevational view thereof;

FIG. 10 is a bottom plan view thereof.

The broken line wires of FIGS. 1-2, 4-6 are environmental only and form no part of the claimed design.

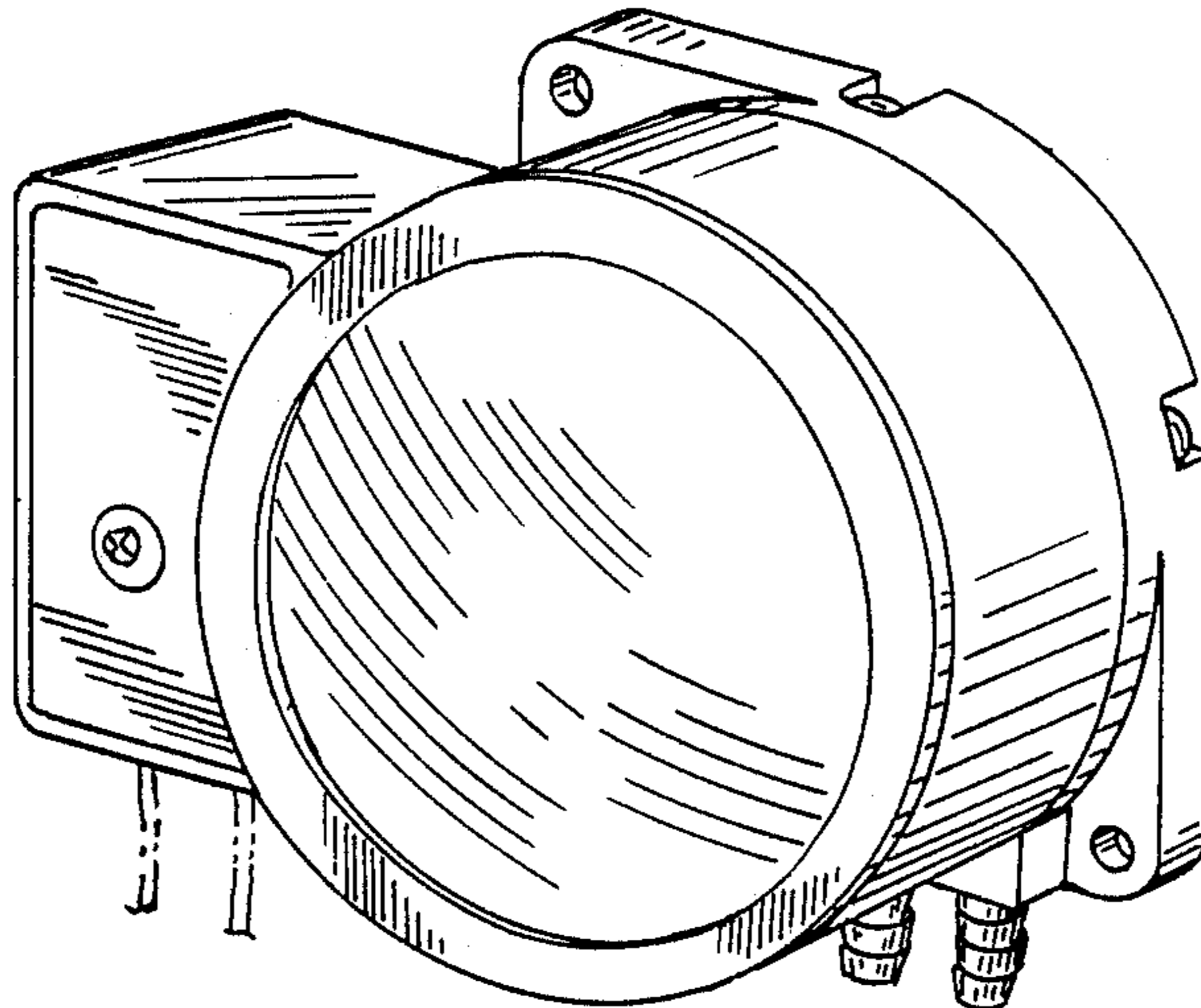

FIG. 1.

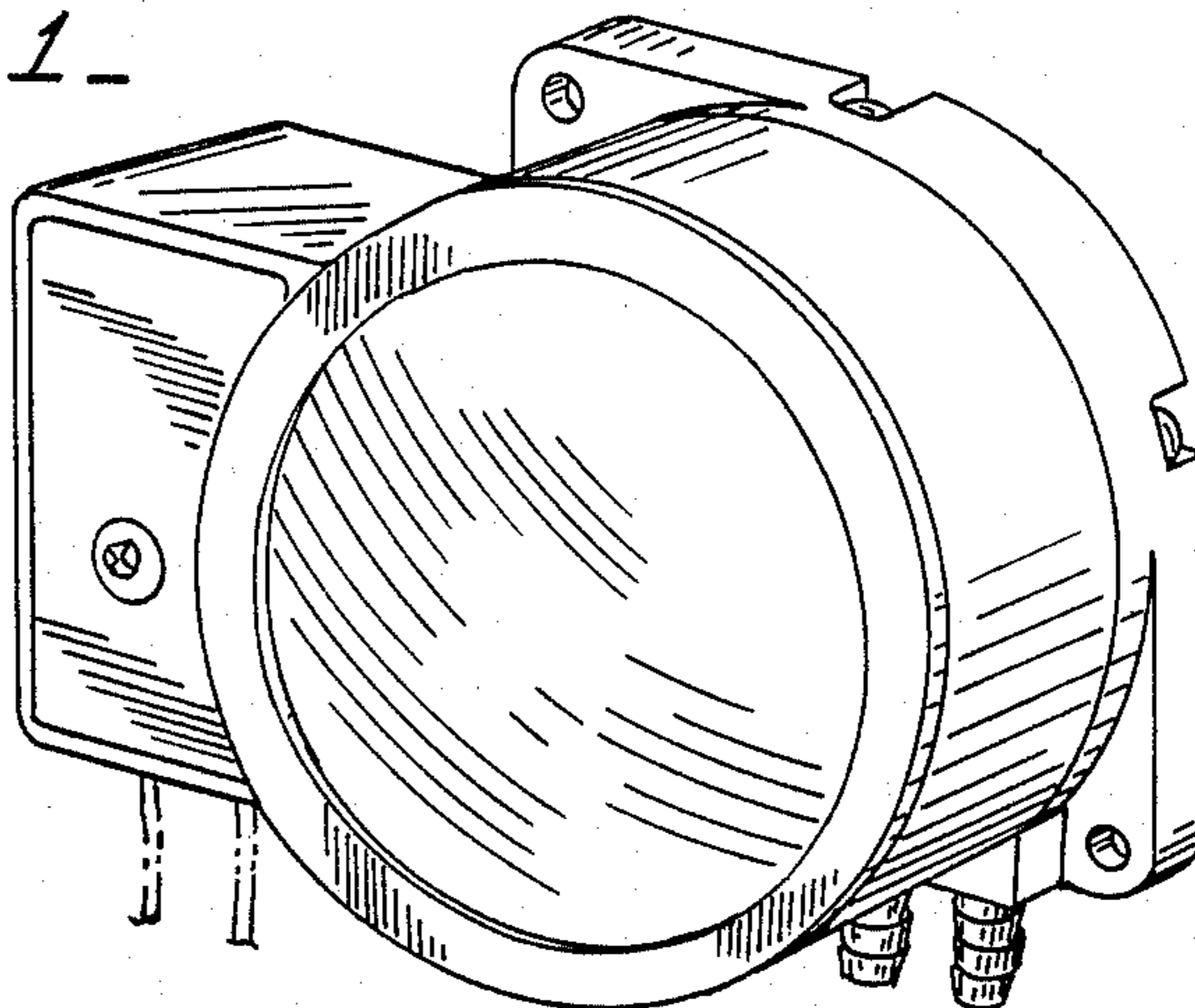

FIG. 2.

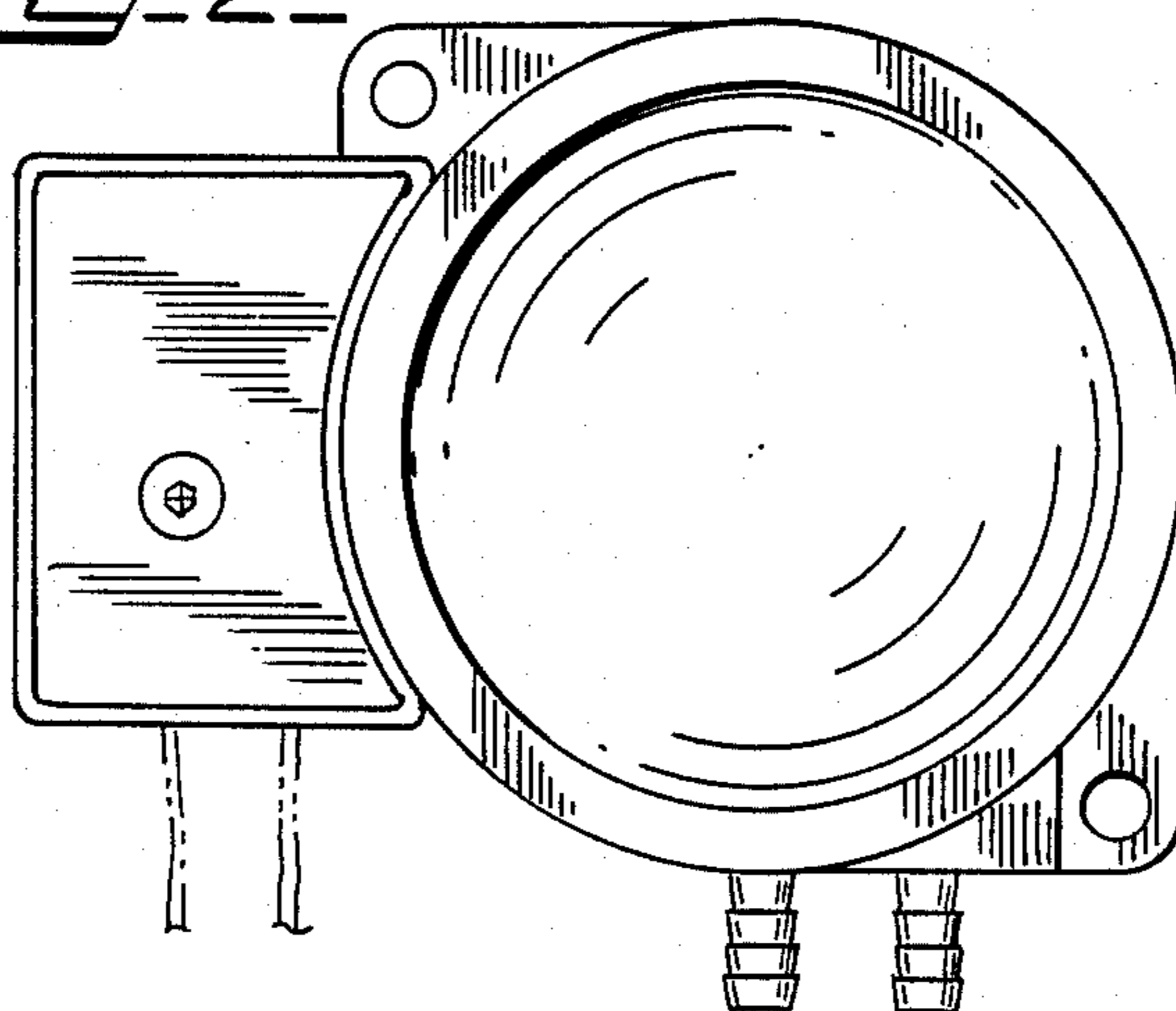
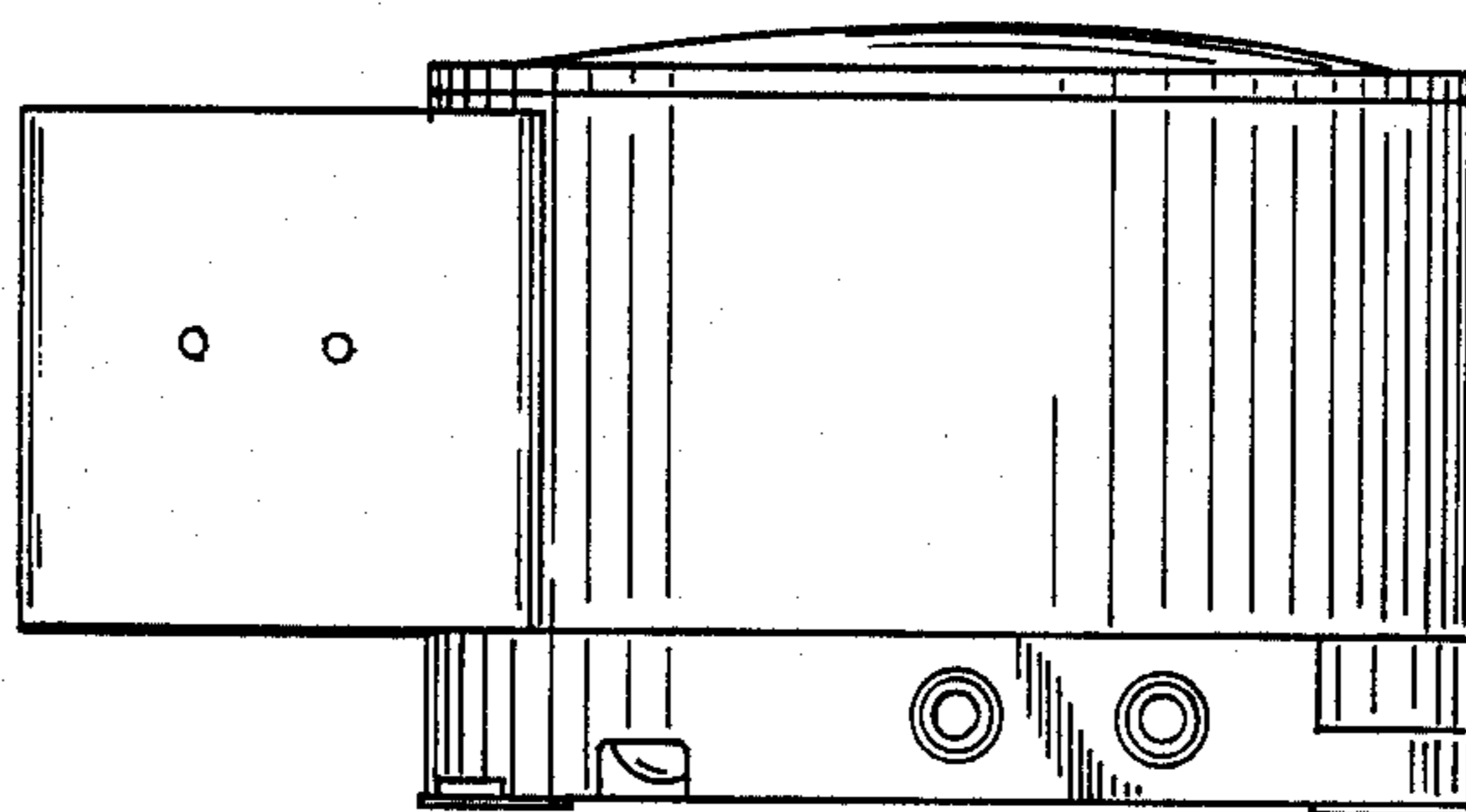

FIG. 3.



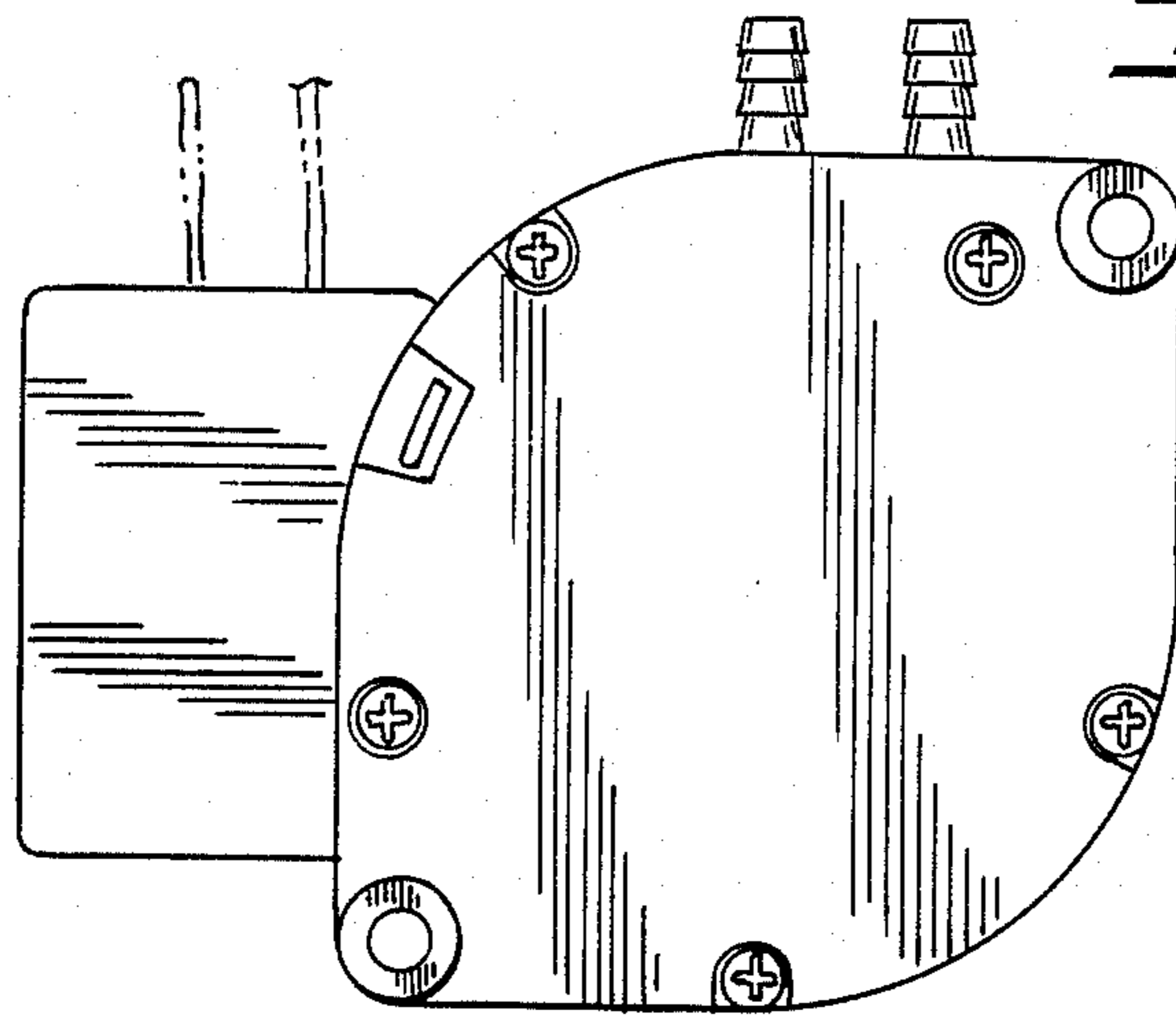

FIG. 4

FIG. 5

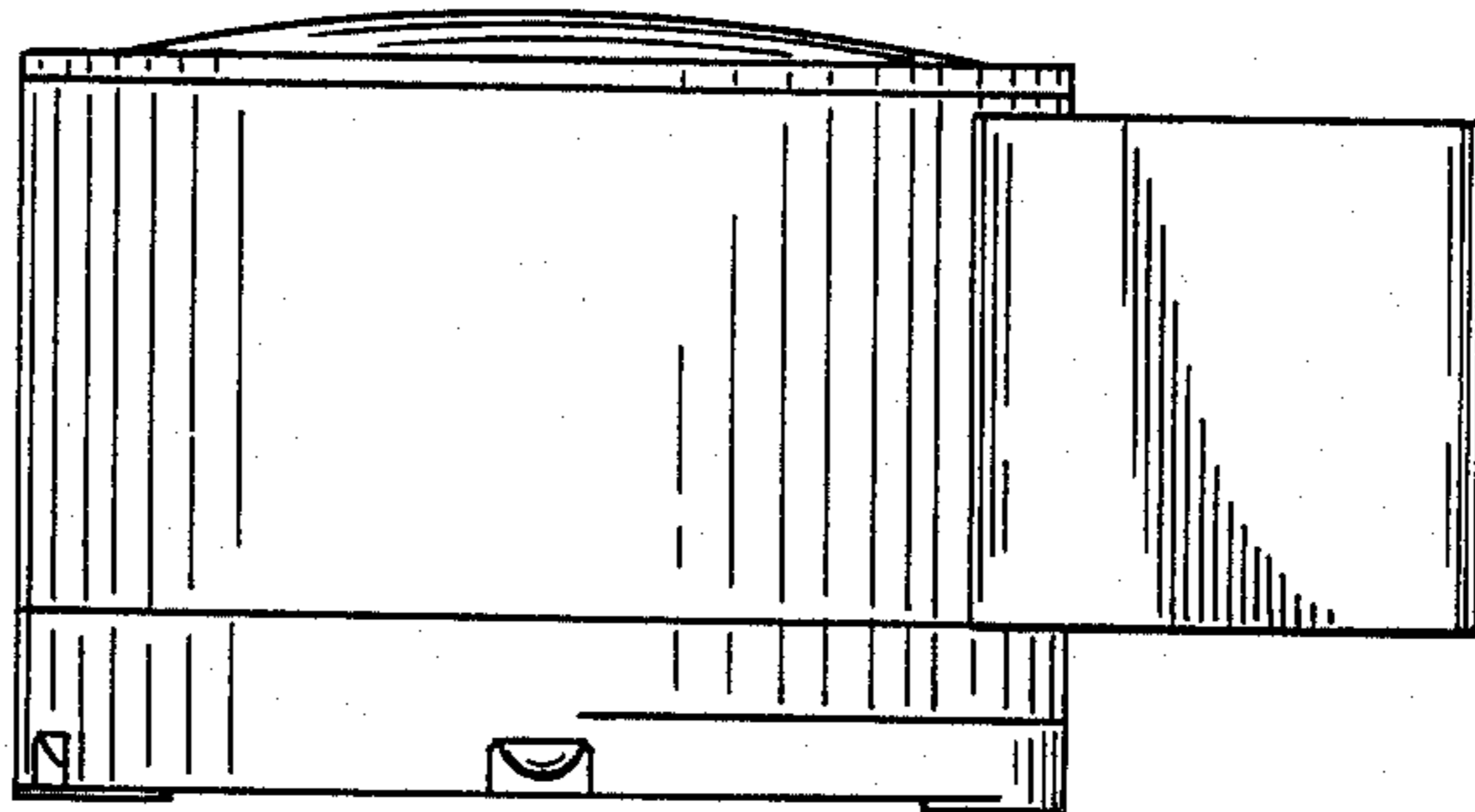

FIG. 6

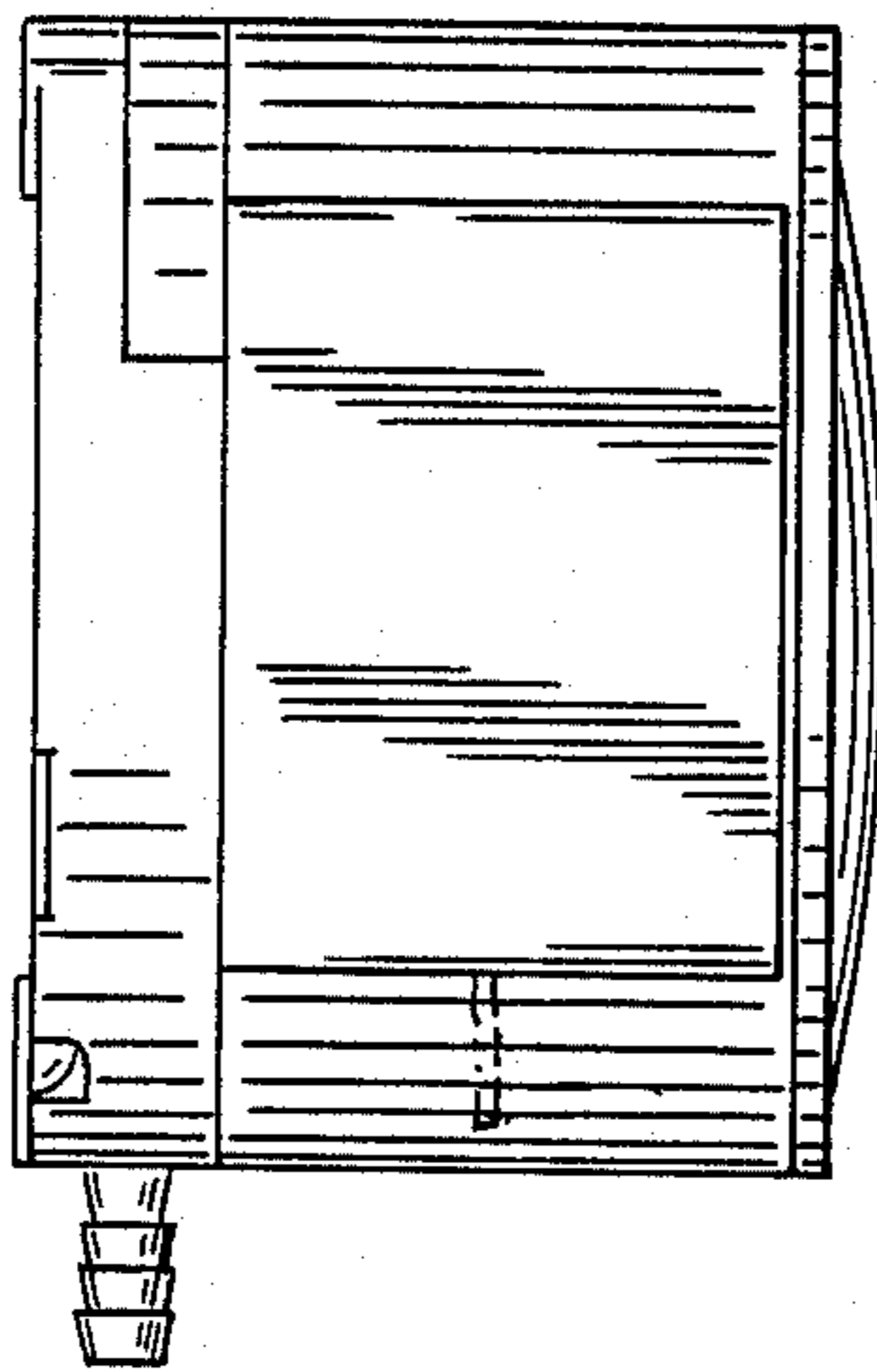

FIG. 7

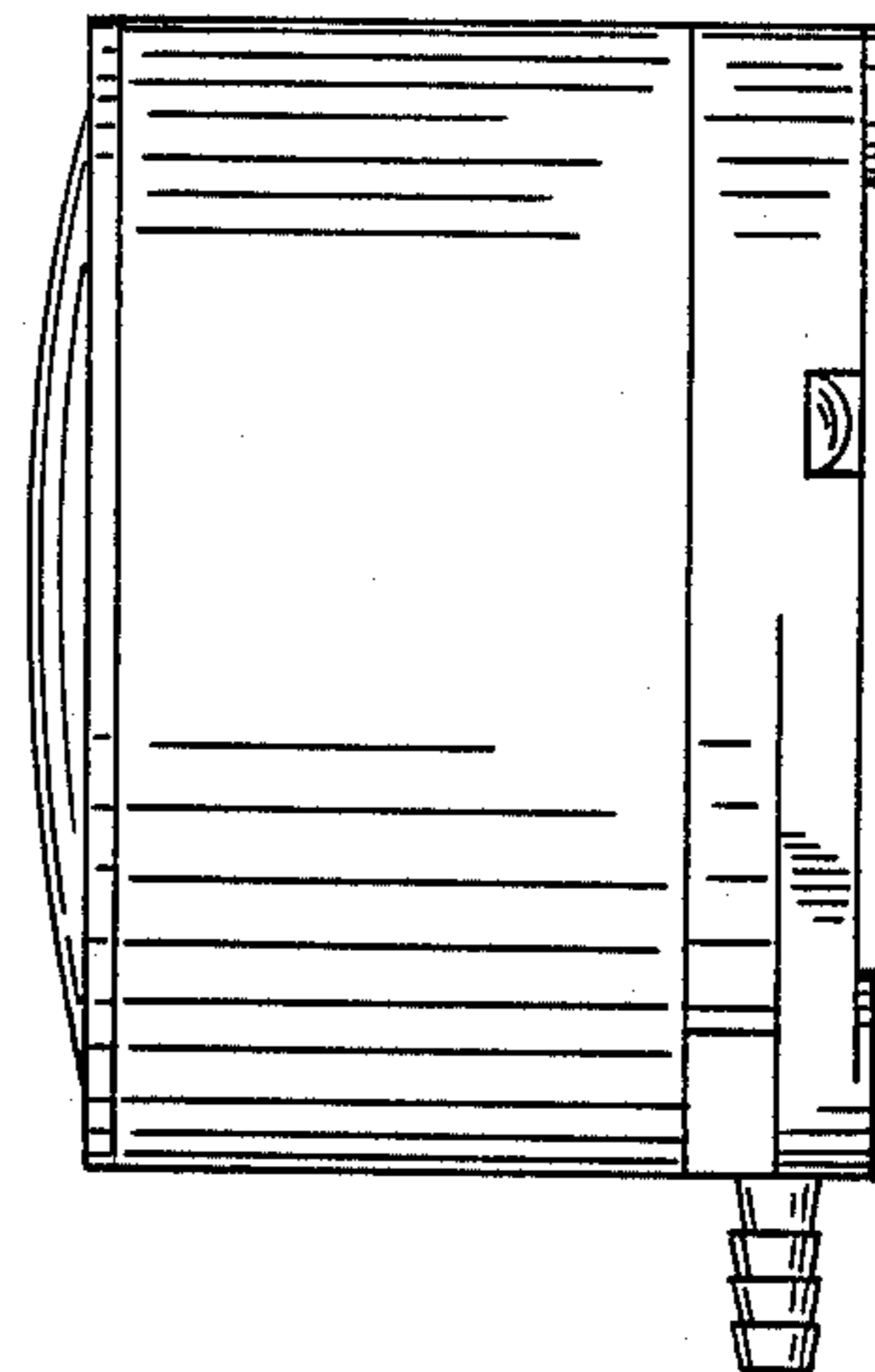

FIG. 8

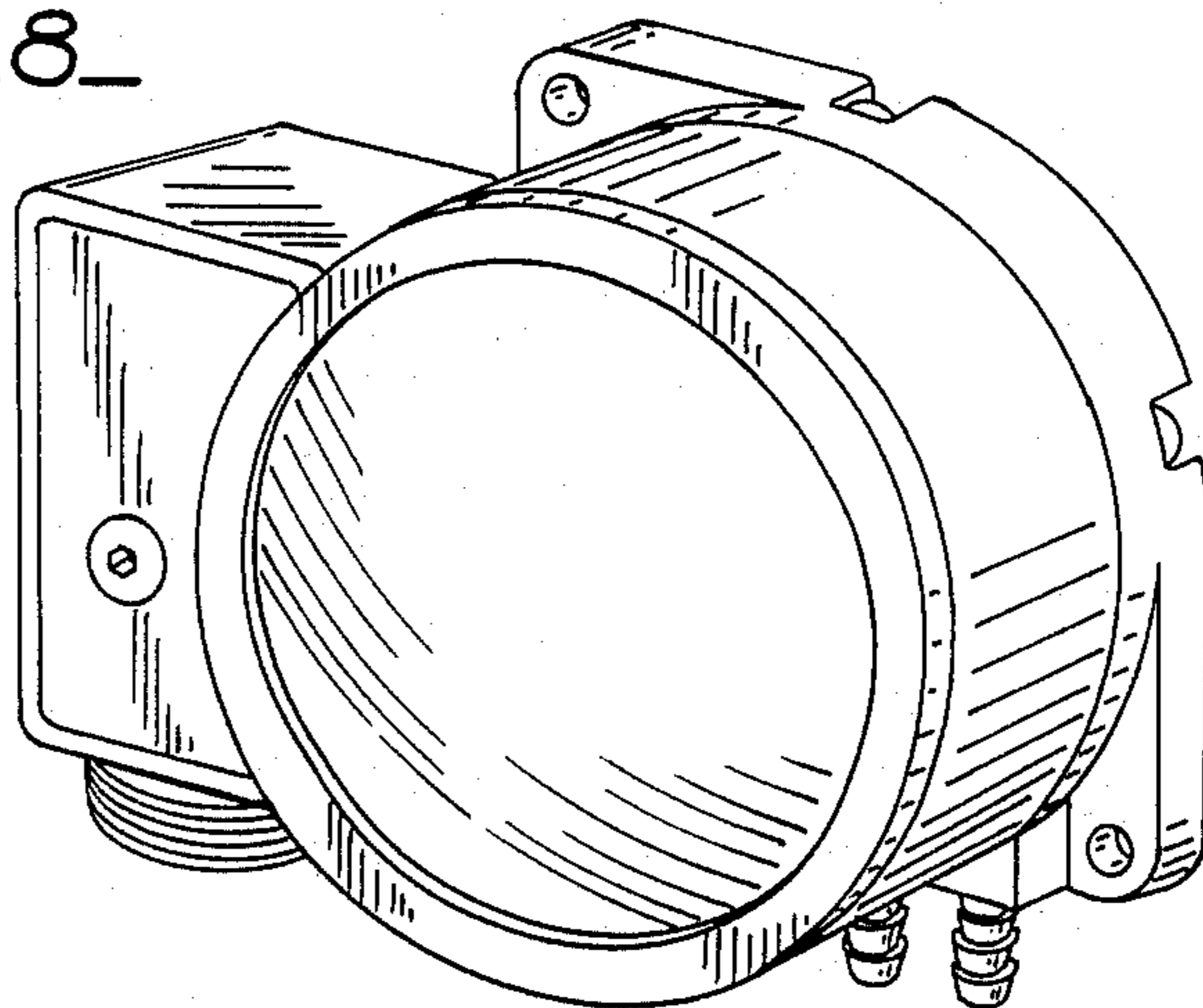

FIG. 9

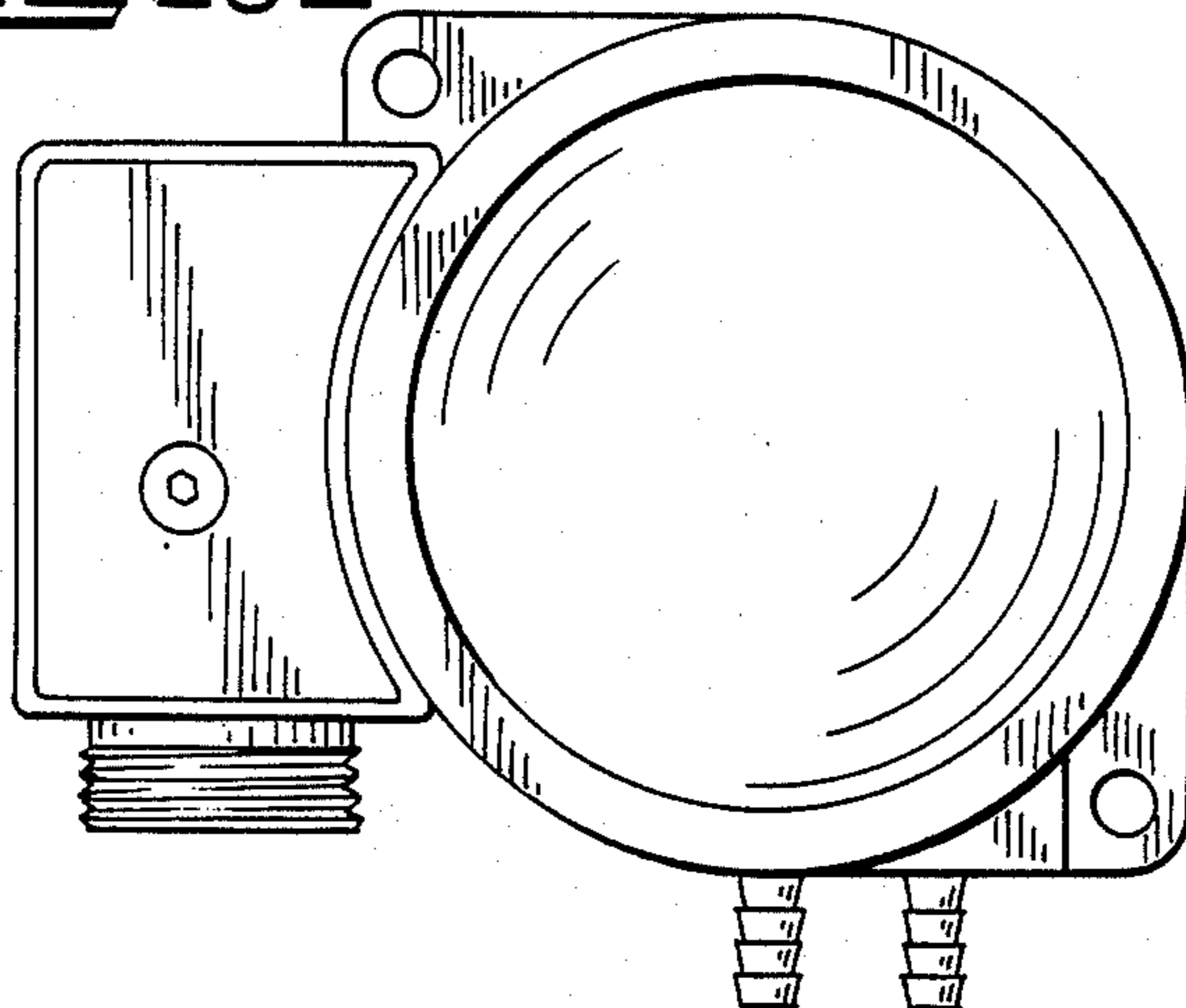

FIG. 10

