

[54] **STOPWATCH**

[75] **Inventor: John T. Houlihan, Watertown, Conn.**

[73] **Assignee: Timex Corporation, Middlebury, Conn.**

[**] **Term: 14 Years**

[21] **Appl. No.: 897,451**

[22] **Filed: Aug. 18, 1986**

[52] **U.S. Cl. D10/30; D10/15**

[58] **Field of Search D10/30-39, D10/122-126; 368/107-114, 80-82, 239-242**

[56] **References Cited**

U.S. PATENT DOCUMENTS

D. 267,784	2/1983	Heurer	D10/30
D. 267,785	2/1983	Heurer	D10/30
D. 268,168	3/1983	Schneider	D10/30
D. 268,485	4/1983	Claude	D10/38
D. 269,502	6/1983	Tanaka	D10/38
D. 295,841	5/1988	Kano	D10/39

OTHER PUBLICATIONS

Interior Design-4/85, p. 65-Stopwatch at bottom-left.
Jeweler's Circular-Keystone-4/78, p. 12-Stopwatch at bottom.

Hong Kong Enterprises-7/85, p. 122-Stopwatch at bottom-left.

Primary Examiner—Nelson C. Holtje
Attorney, Agent, or Firm—William C. Crutcher

[57] **CLAIM**

The ornamental design for a stopwatch, as shown and described.

DESCRIPTION

FIG. 1 is a top plan view of a stopwatch showing my new design with a representative digital readout; FIG. 2 is a front elevational view thereof; FIG. 3 is a bottom plan view thereof; FIG. 4 is a rear elevational view thereof; FIG. 5 is a right side elevational view thereof; FIG. 6 is a left side elevational view thereof.

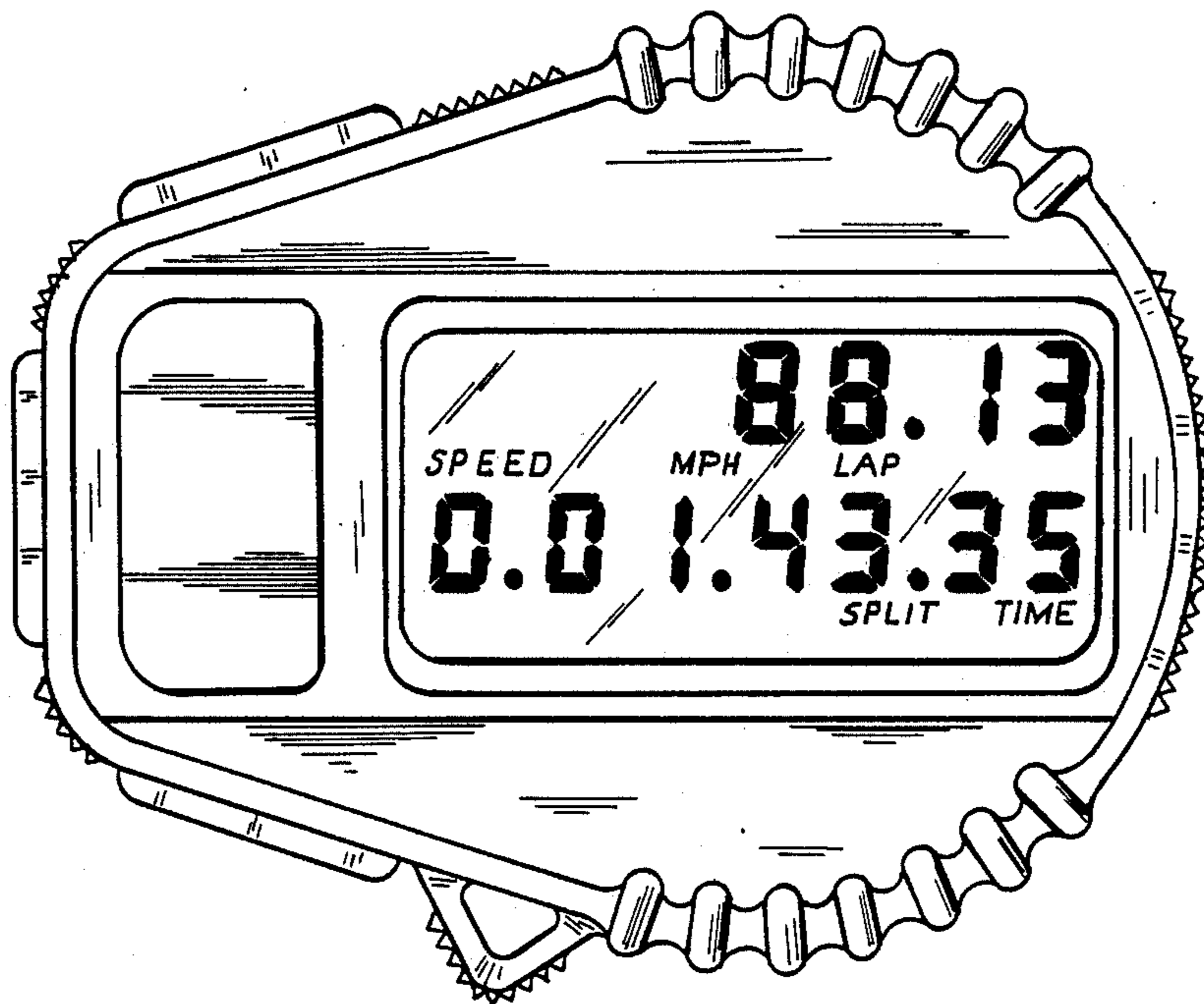

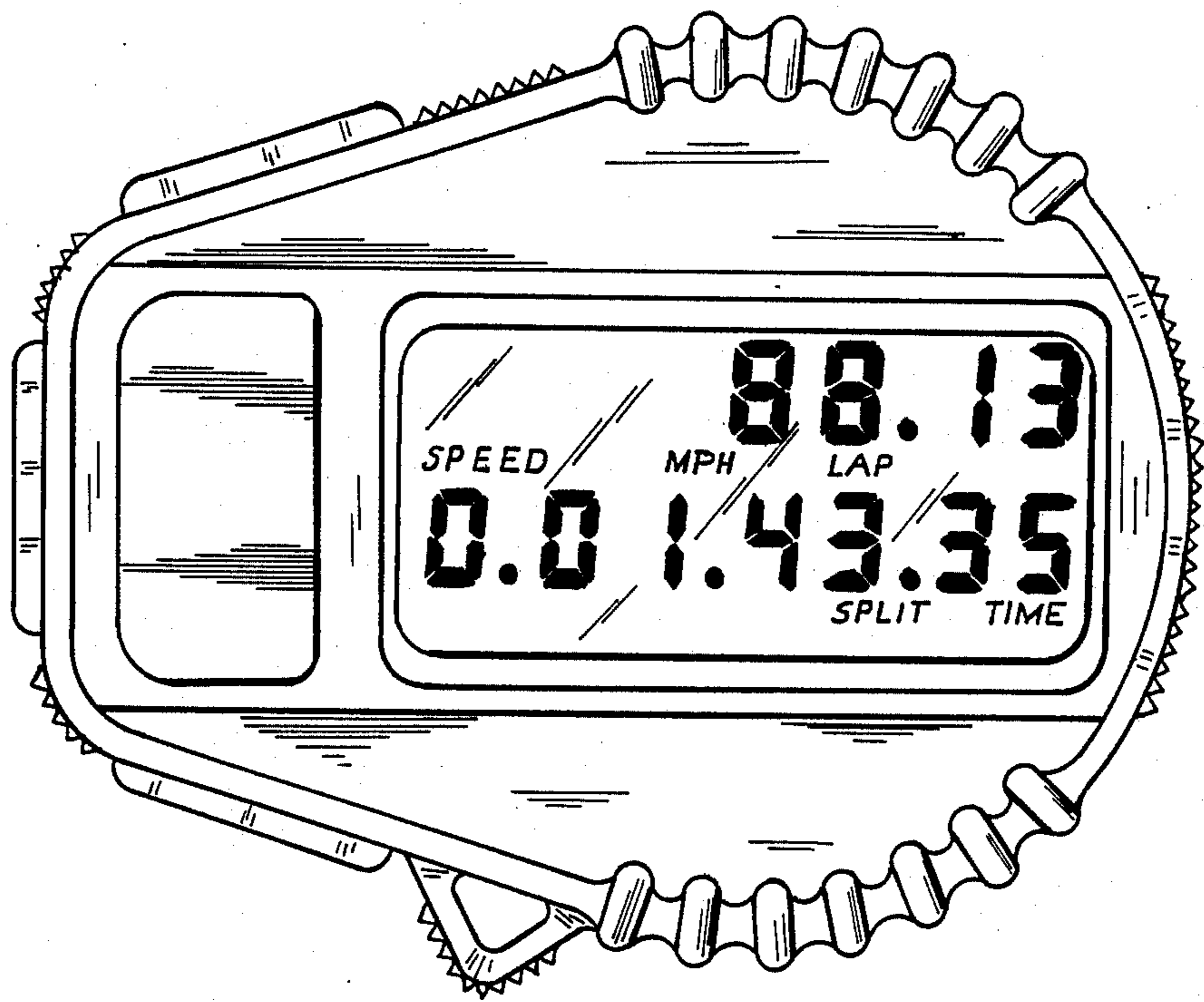

FIG. 1

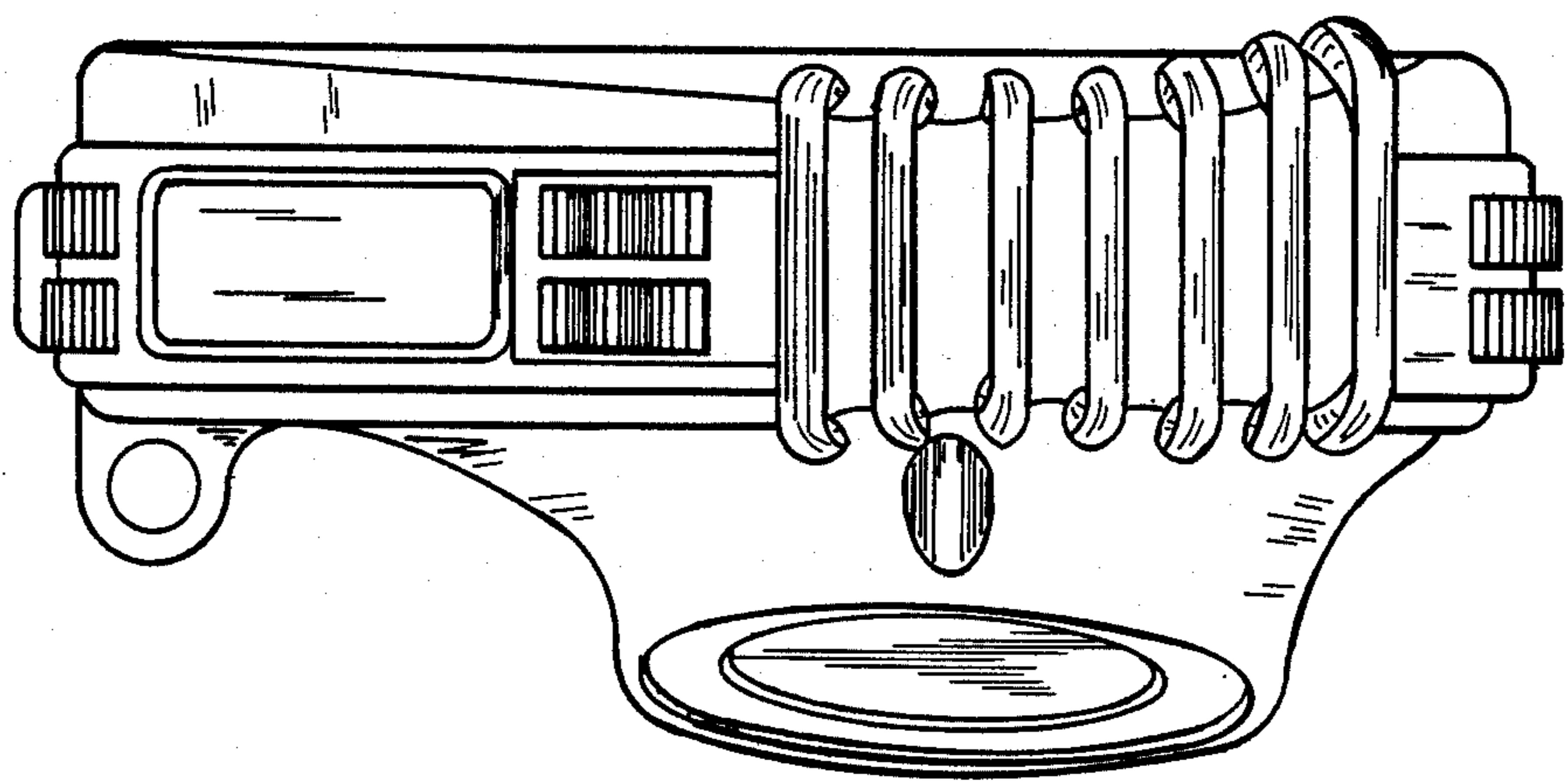

FIG. 2

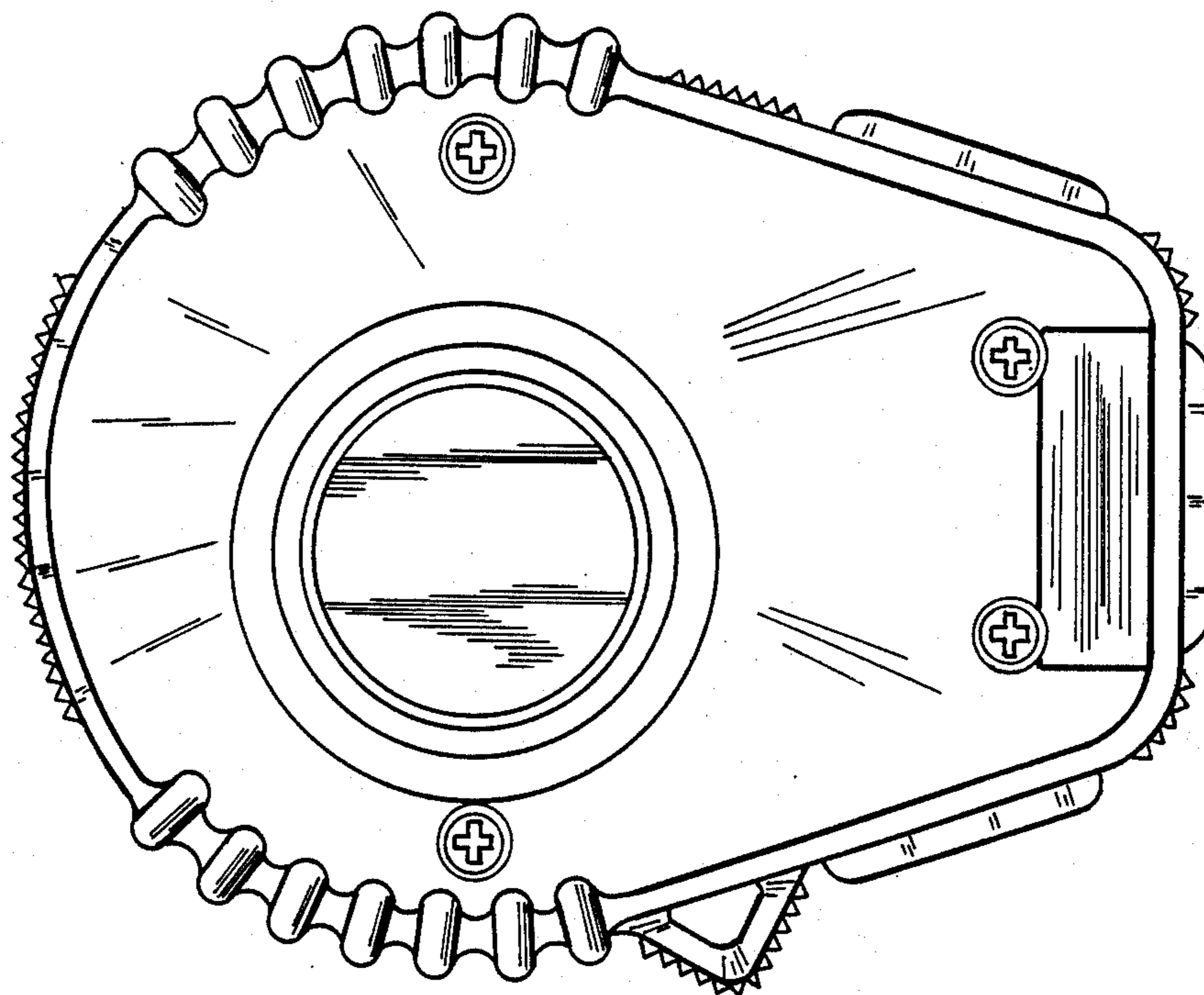

FIG. 3

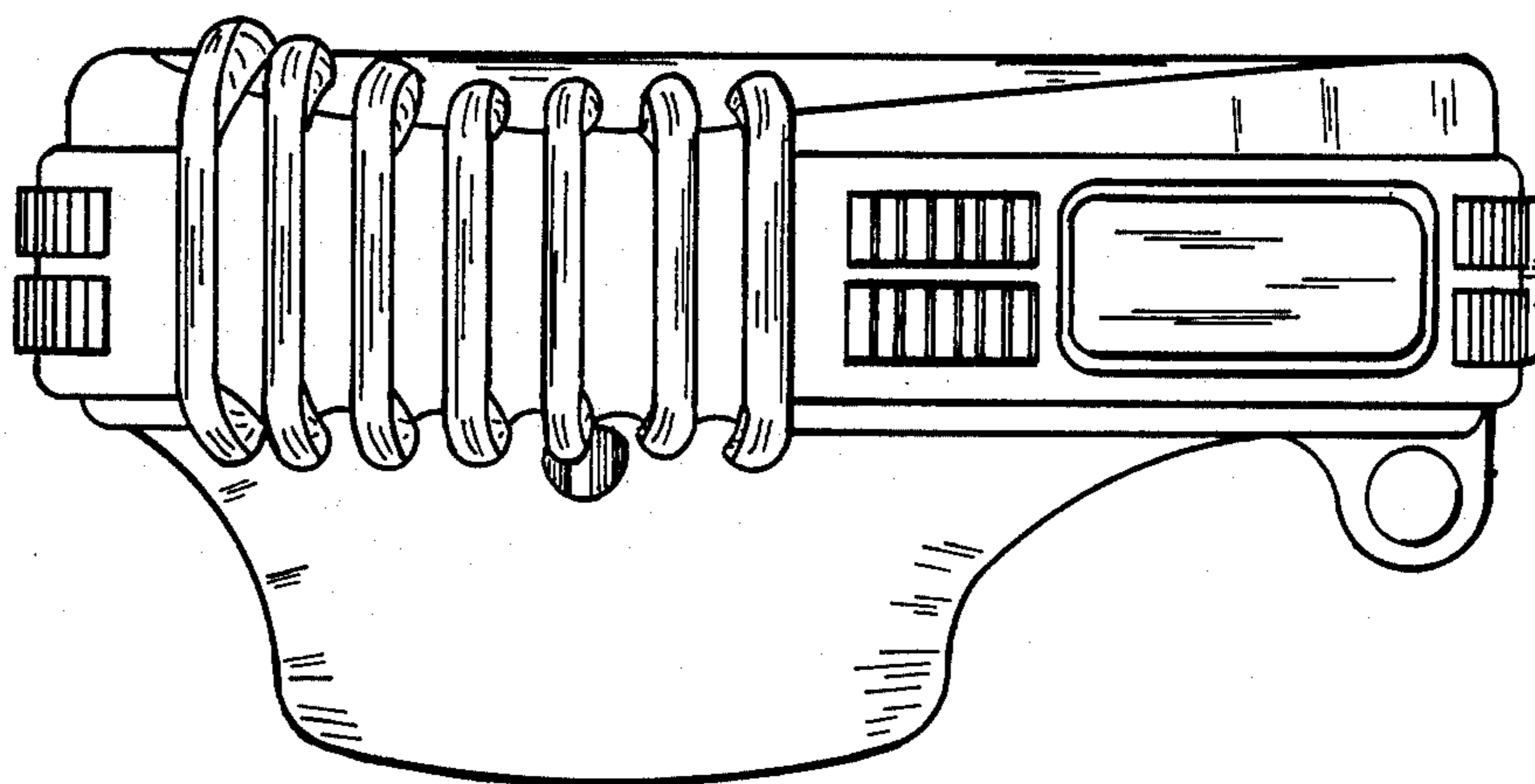

FIG. 4

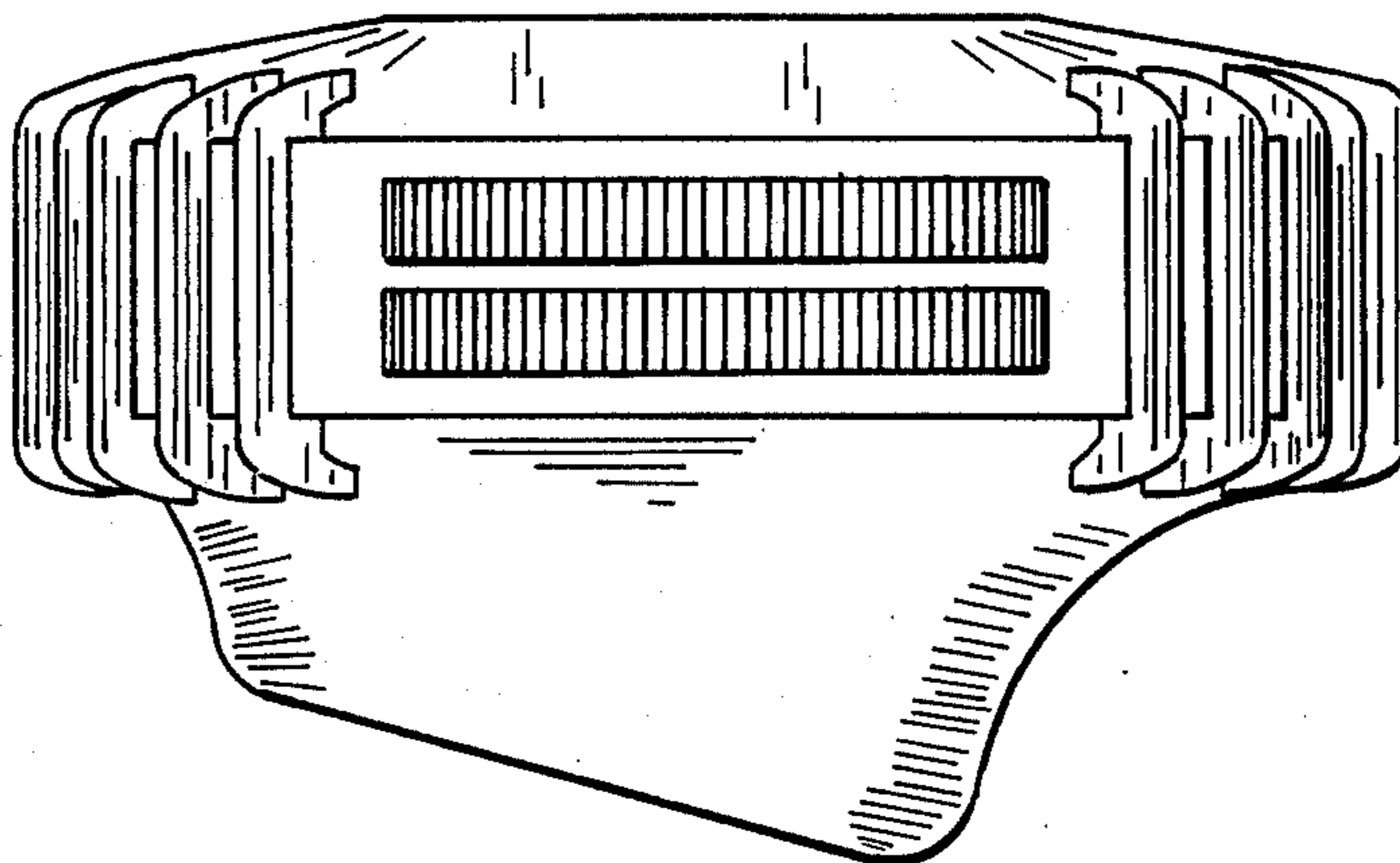

FIG. 5

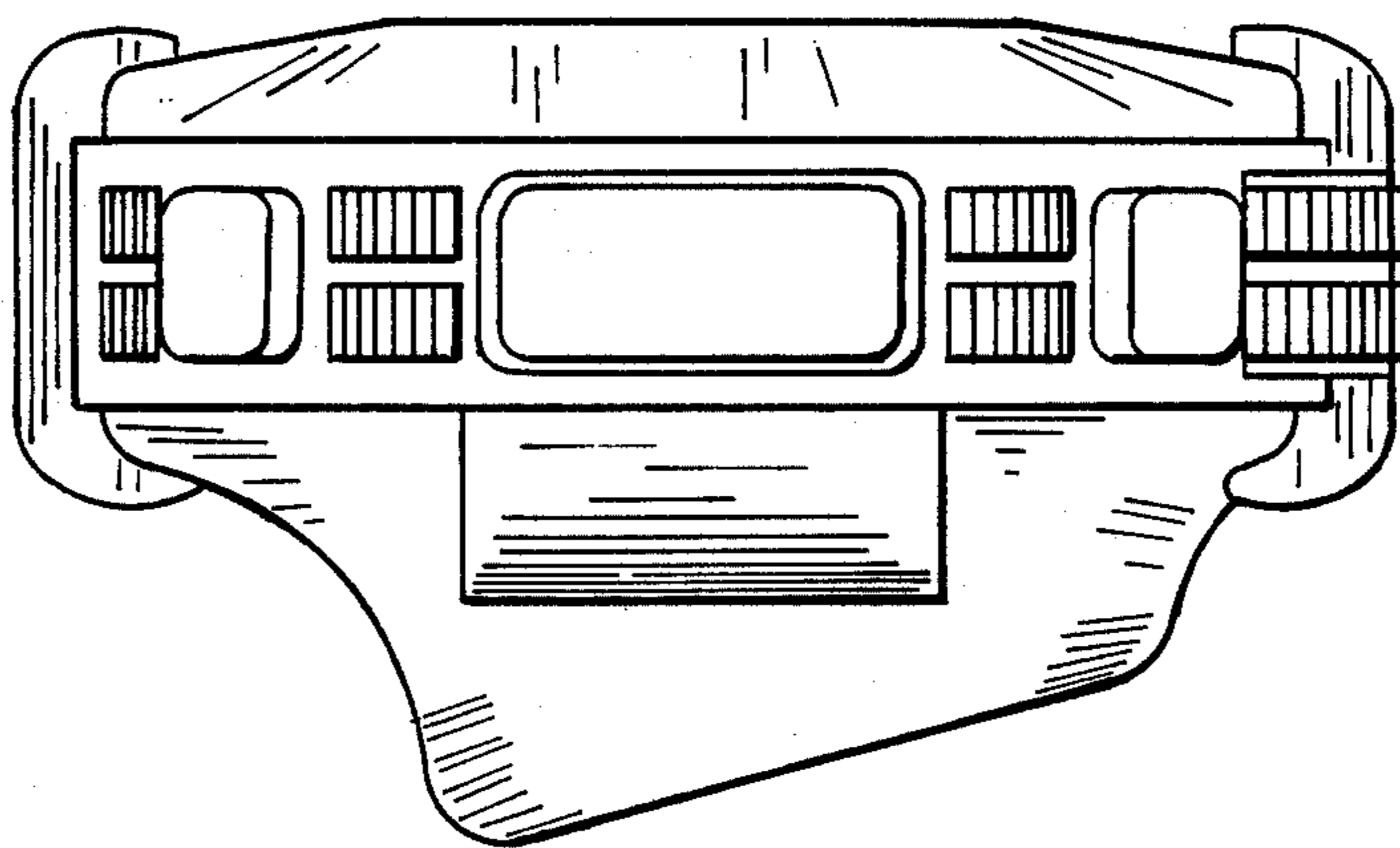

FIG. 6