

# United States Patent [19]

Watanabe et al.

[11] Patent Number: **Des. 300,977**

[45] Date of Patent: **\*\* May 2, 1989**

[54] **TRACKED LOAD CARRYING VEHICLE**

[75] Inventors: **Masahiro Watanabe; Masaki Furusawa, both of Wako, Japan**

[73] Assignee: **Honda Giken Kogyo Kabushiki Kaisha, Tokyo, Japan**

[\*\*] Term: **14 Years**

[21] Appl. No.: **831,918**

[22] Filed: **Feb. 21, 1986**

[30] **Foreign Application Priority Data**

Sep. 3, 1985 [JP] Japan ..... 60-37258

[52] U.S. Cl. .... **D34/28; D12/1**

[58] Field of Search ..... **D34/28; D12/1, 12; 280/5.22, 47.32; 180/19.1, 9, 9.22**

[56] **References Cited**

## U.S. PATENT DOCUMENTS

3,789,941 2/1974 Robertson ..... 180/9.22  
4,033,421 7/1977 Ikarimoto ..... 180/9.22  
4,144,945 3/1979 Hamilton ..... 180/19.1

4,645,022 2/1987 Bergquist ..... 180/9.22  
4,747,457 5/1988 Buscarolo et al. .... 180/9.22

## FOREIGN PATENT DOCUMENTS

198138 11/1957 Austria ..... 180/9.22  
2354712 5/1974 Fed. Rep. of Germany ..... 180/9  
65927 5/1979 Japan ..... 180/9.22

*Primary Examiner*—Wallace R. Burke

*Assistant Examiner*—Kay H. Chin

*Attorney, Agent, or Firm*—Wenderoth, Lind & Ponack

[57] **CLAIM**

The ornamental design for a tracked load carrying vehicle, as shown and described.

## DESCRIPTION

FIG. 1 is a front elevational view of a tracked load carrying vehicle showing our new design; FIG. 2 is a rear elevational view thereof; FIG. 3 is right side elevational view thereof; FIG. 4 is a left side elevational view thereof; FIG. 5 is a top plan view thereof; FIG. 6 is a bottom plan view thereof; and FIG. 7 is a right side perspective view thereof.

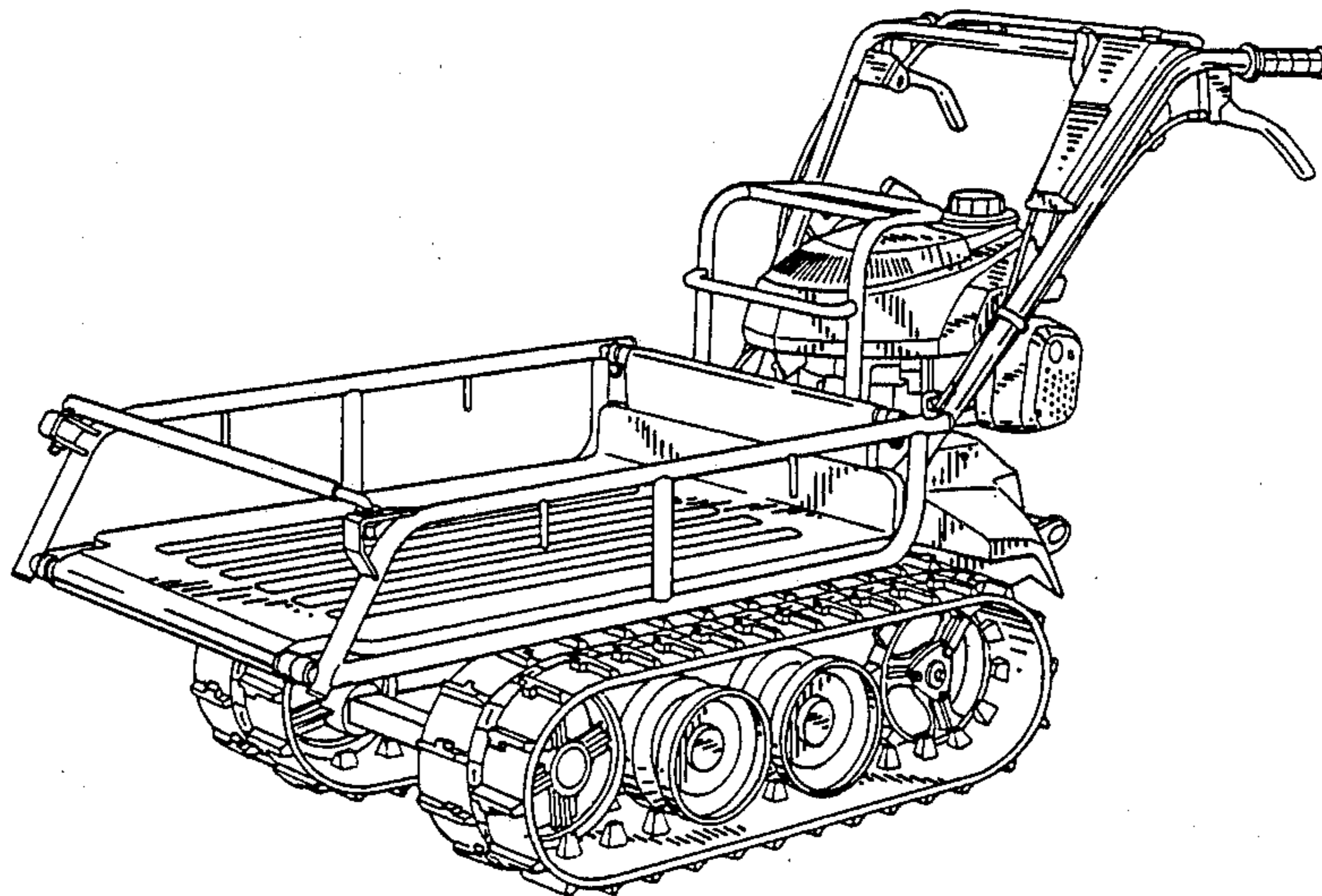

FIG. 1

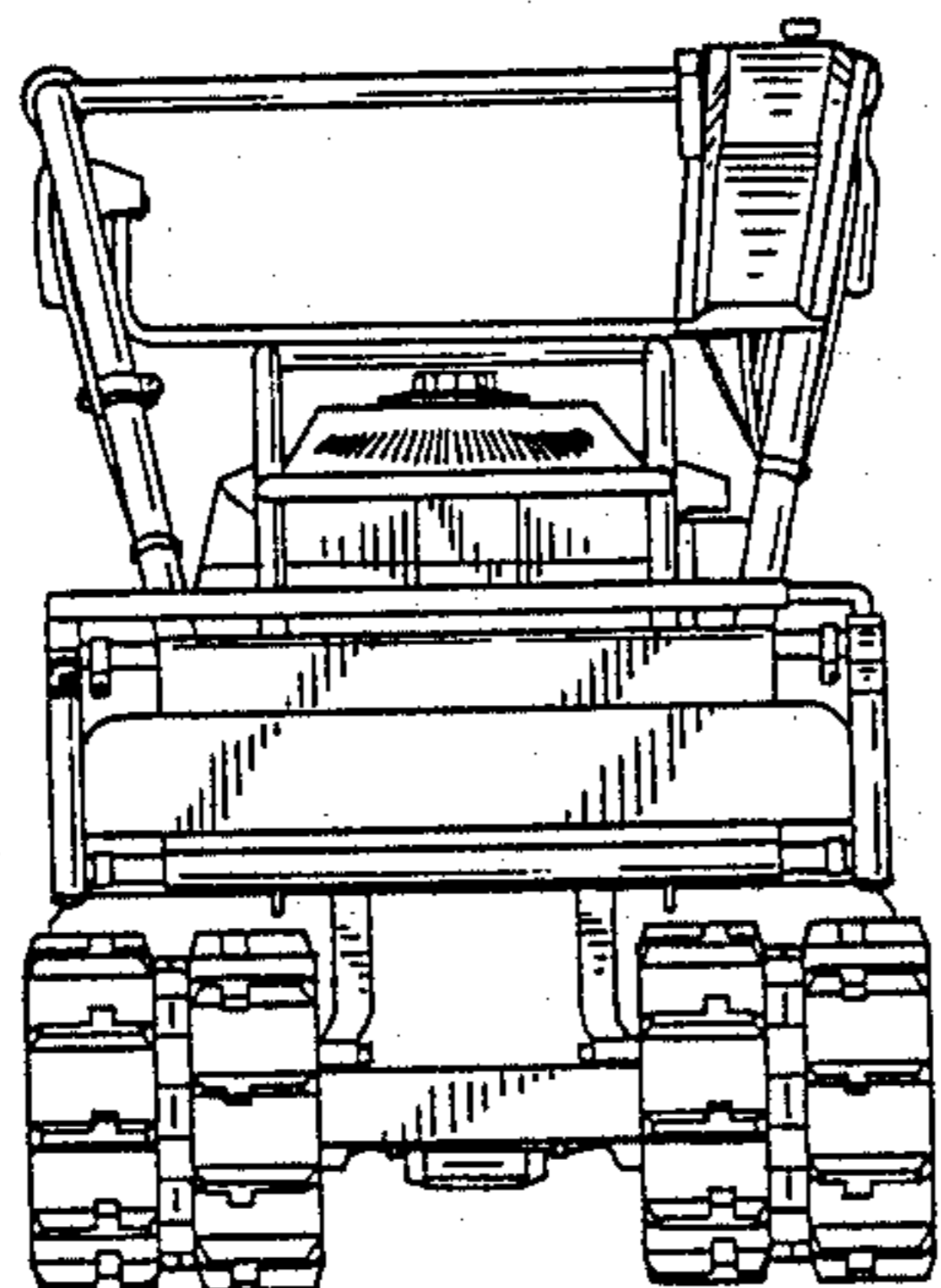

FIG. 2

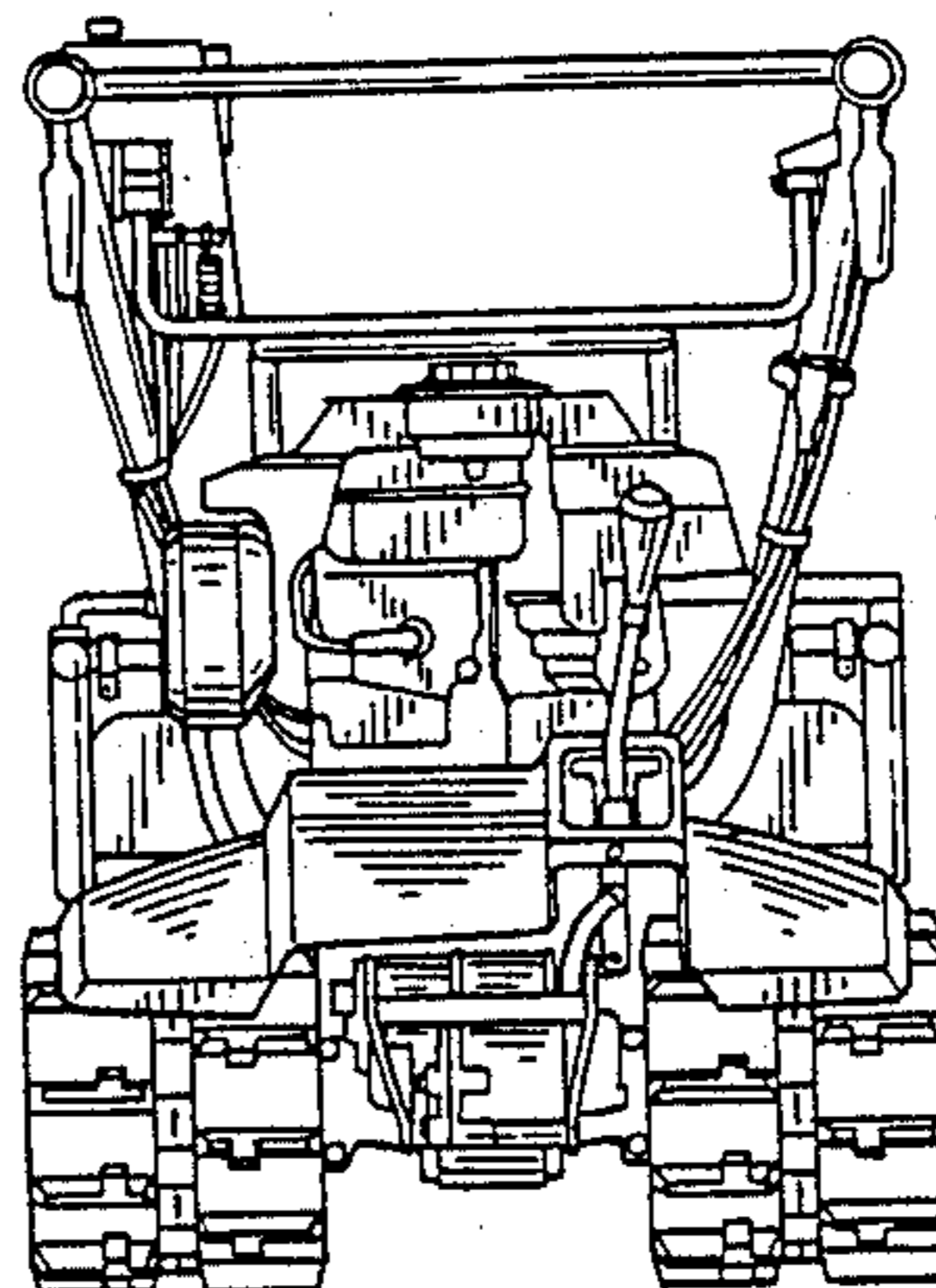

FIG. 3

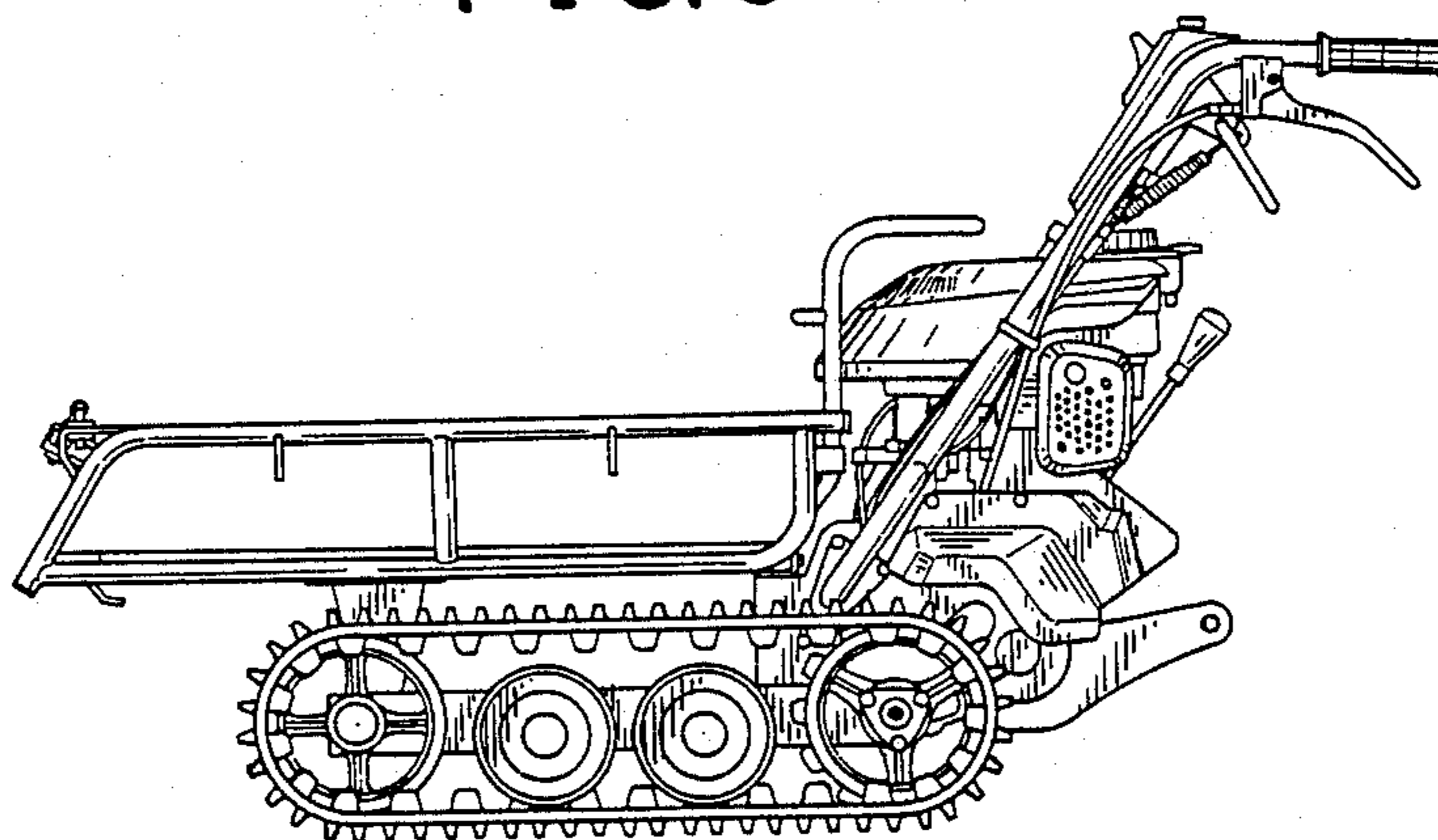

FIG. 4

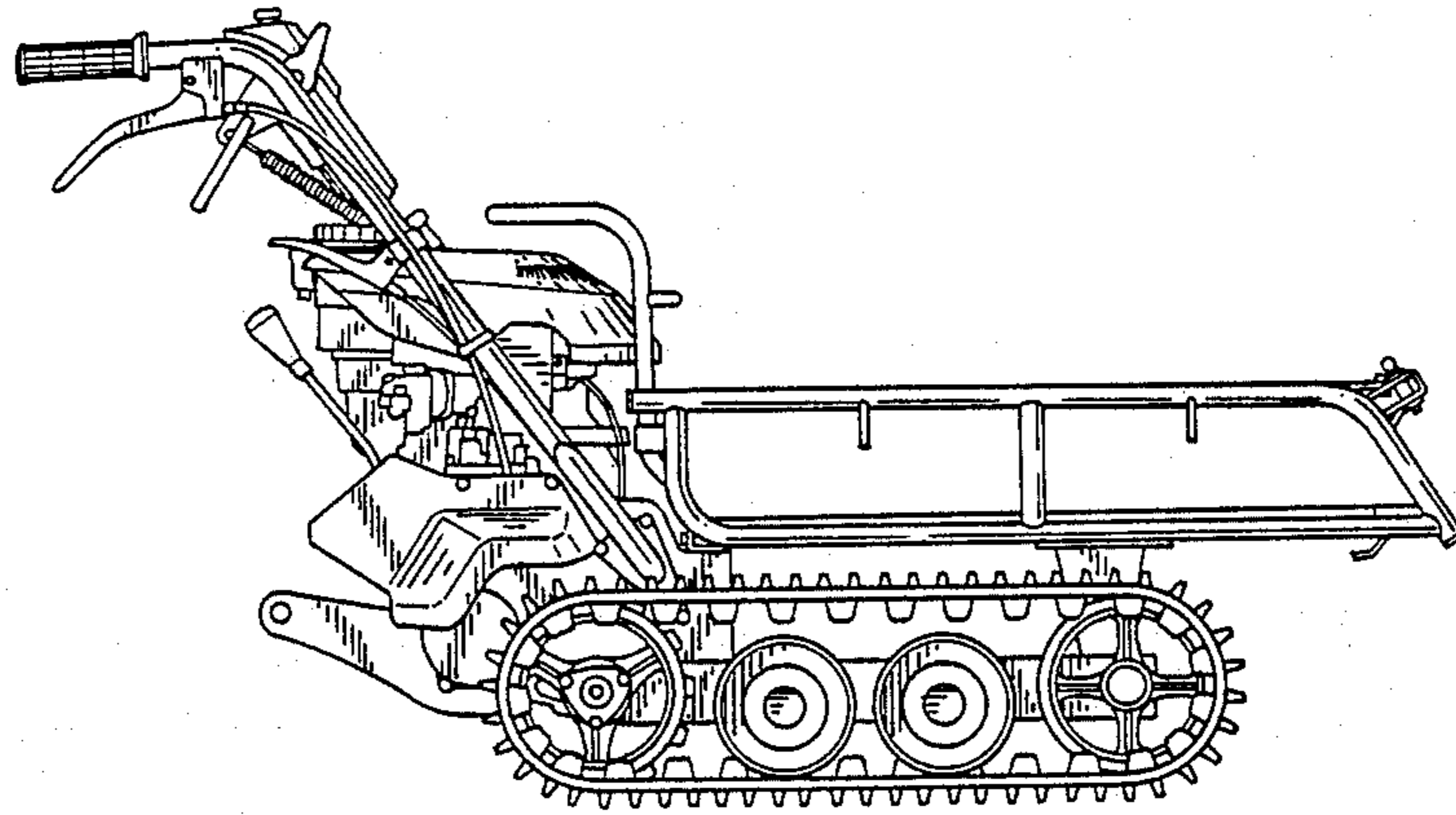

FIG. 5

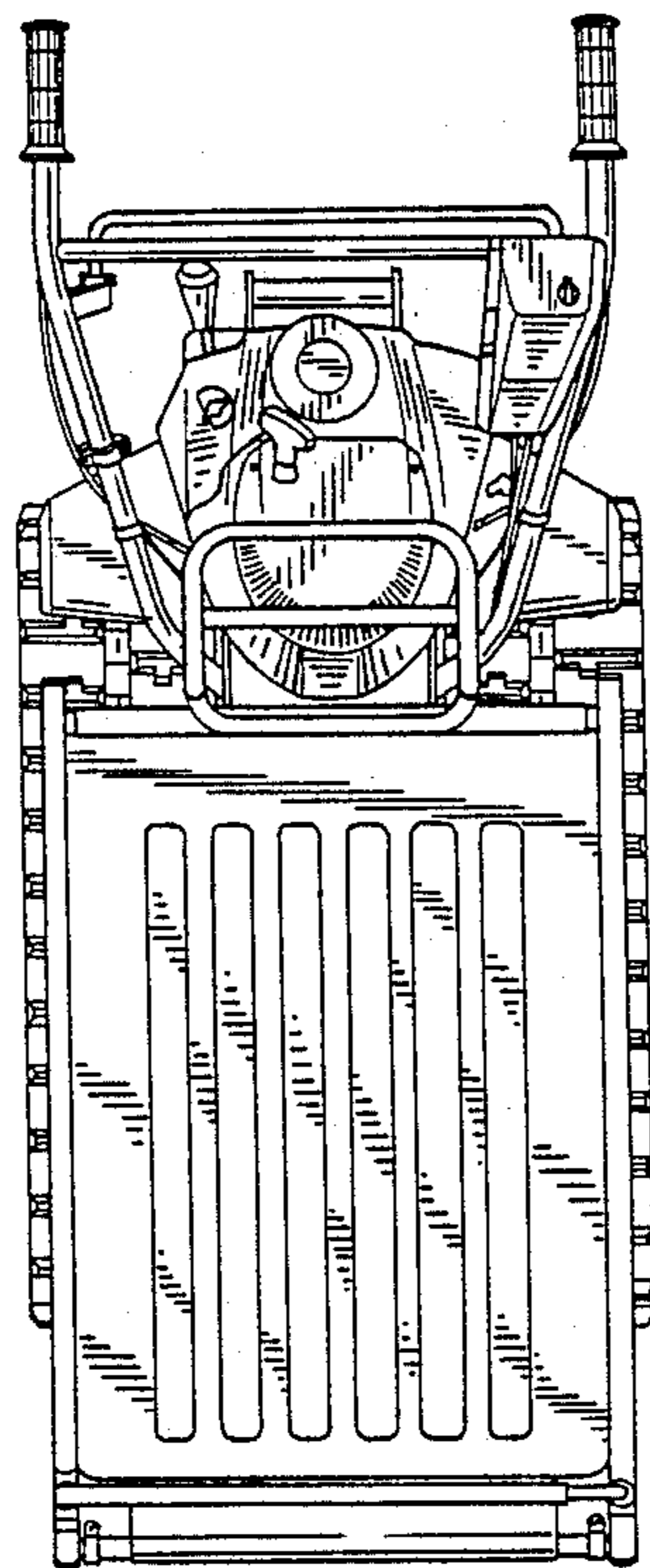

FIG. 6

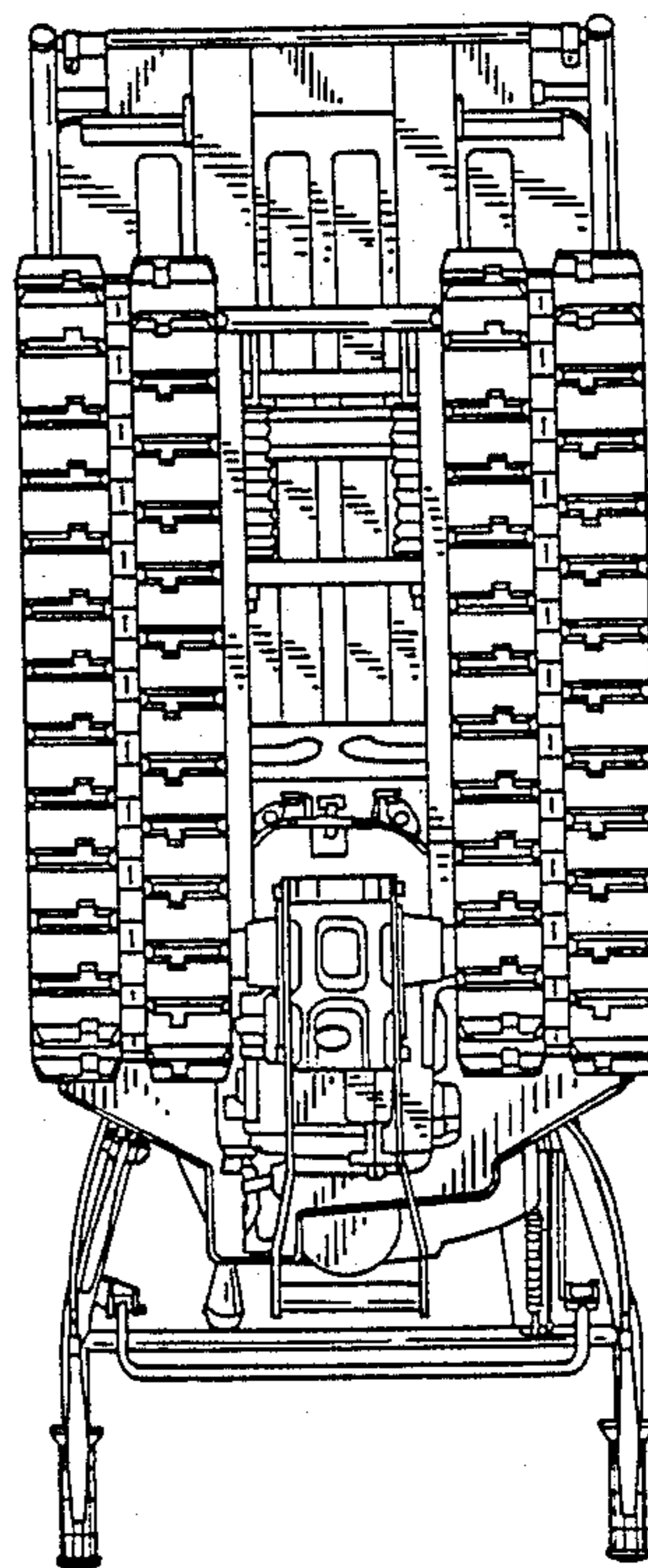

FIG. 7

