

[54] COMBINED COURTESY AND ADJUSTABLE LIGHT FOR THE INTERIOR OF AUTOMOTIVE VEHICLES

[76] Inventor: Anthony Macaluso, 6833 Rosecrans Ave., Unit D, Paramount, Calif. 90723

[*] Notice: The portion of the term of this patent subsequent to Apr. 25, 2003 has been disclaimed.

[**] Term: 14 Years

[21] Appl. No.: 942,861

[22] Filed: Dec. 17, 1986

[52] U.S. Cl. D26/28; D26/74

[58] Field of Search D26/28, 29, 72, 74, D26/61, 63, 65; 362/432, 269, 270, 275, 74, 61, 245, 246, 250, 364, 371

[56] References Cited

U.S. PATENT DOCUMENTS

D. 264,007 4/1982 Heritage D26/74

D. 291,253 8/1987 Ortega D26/74 X
D. 294,302 2/1988 Littrell et al. D26/80 X
2,654,830 10/1953 Runge et al. 362/269
4,499,528 2/1985 Hawlitzki 362/61 X

Primary Examiner—Susan J. Lucas
Attorney, Agent, or Firm—Fulwider, Patton, Rieber, Lee & Utecht

[57] CLAIM

The ornamental design for a combined courtesy and adjustable light for the interior of automotive vehicles, as shown and described.

DESCRIPTION

FIG. 1 is a bottom plan view of a combined courtesy and adjustable light for the interior of automotive vehicles showing my new design;
FIG. 2 is a side elevational view thereof, the opposite side being a mirror image;
FIG. 3 is a front elevational view thereof, the rear being a mirror image;
FIG. 4 is a top plan view thereof;
FIG. 5 is a bottom perspective view thereof.

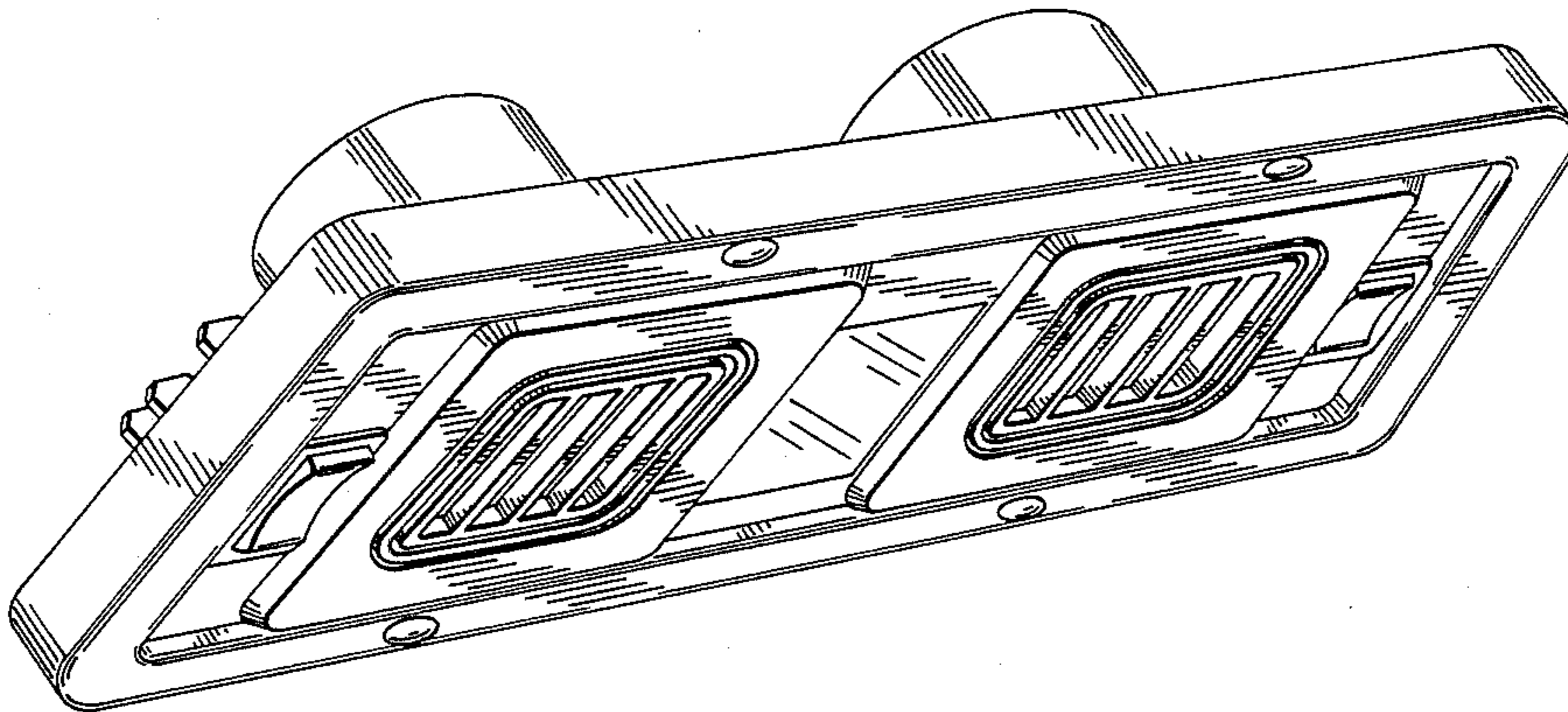

FIG. 1

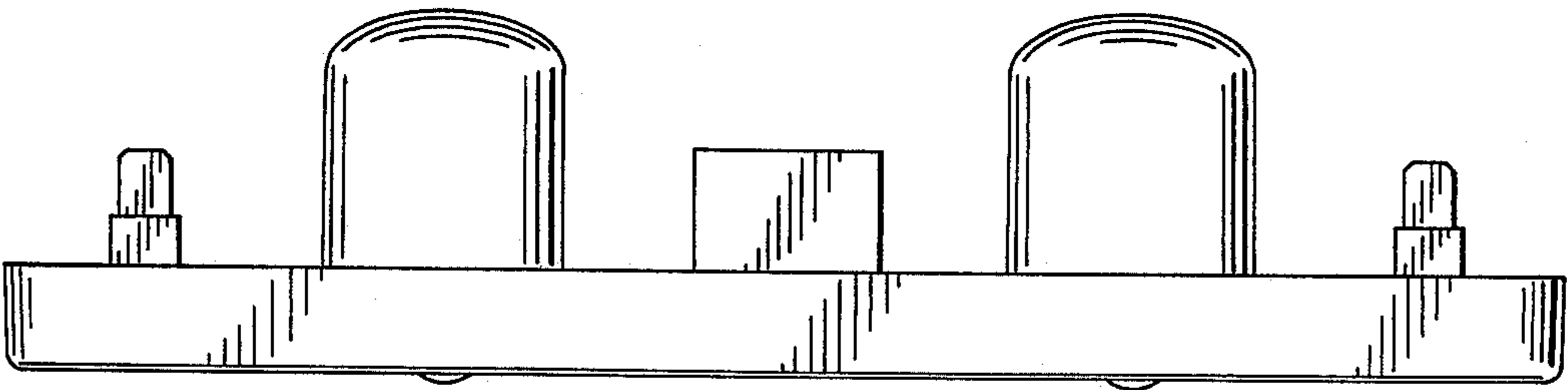
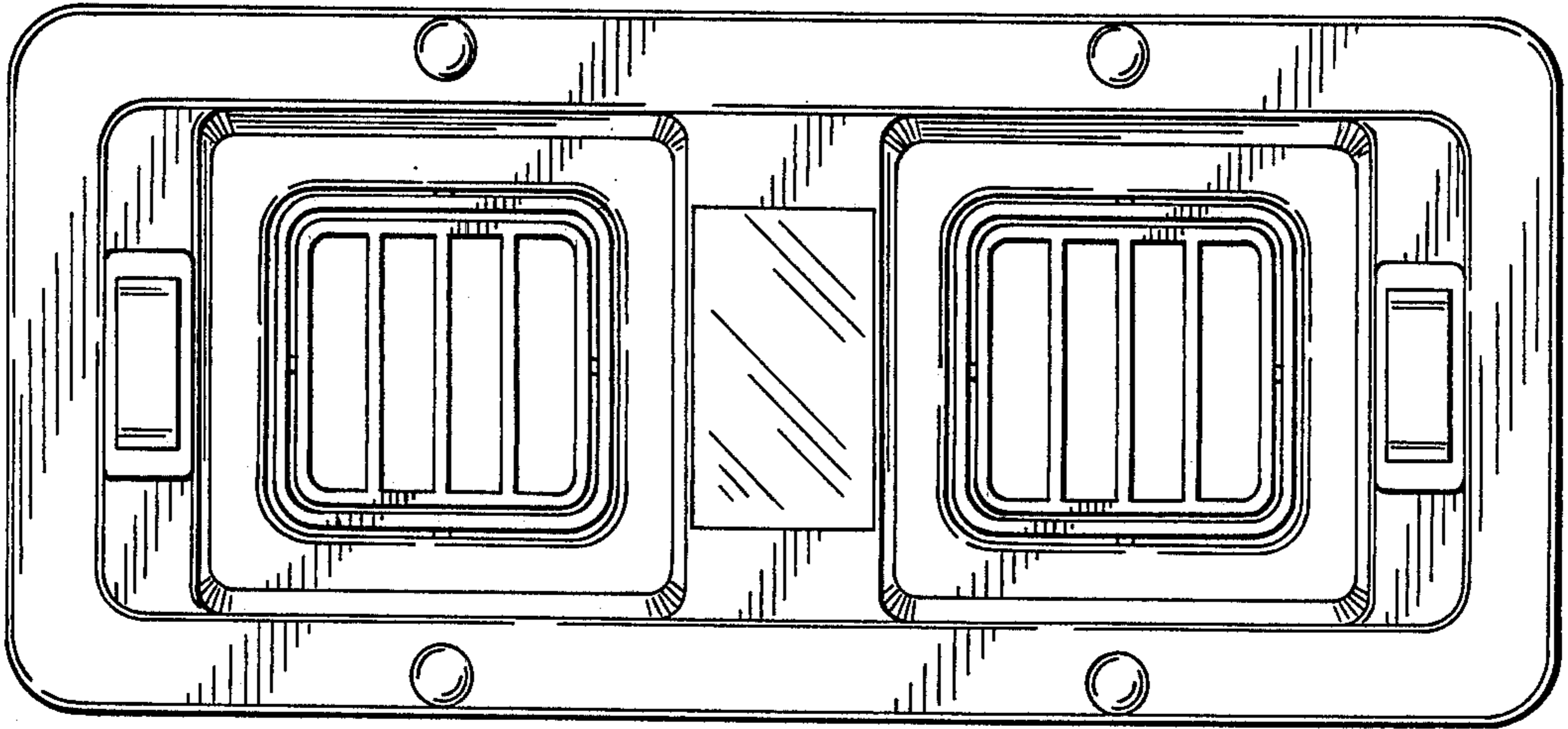

FIG. 2

FIG. 3

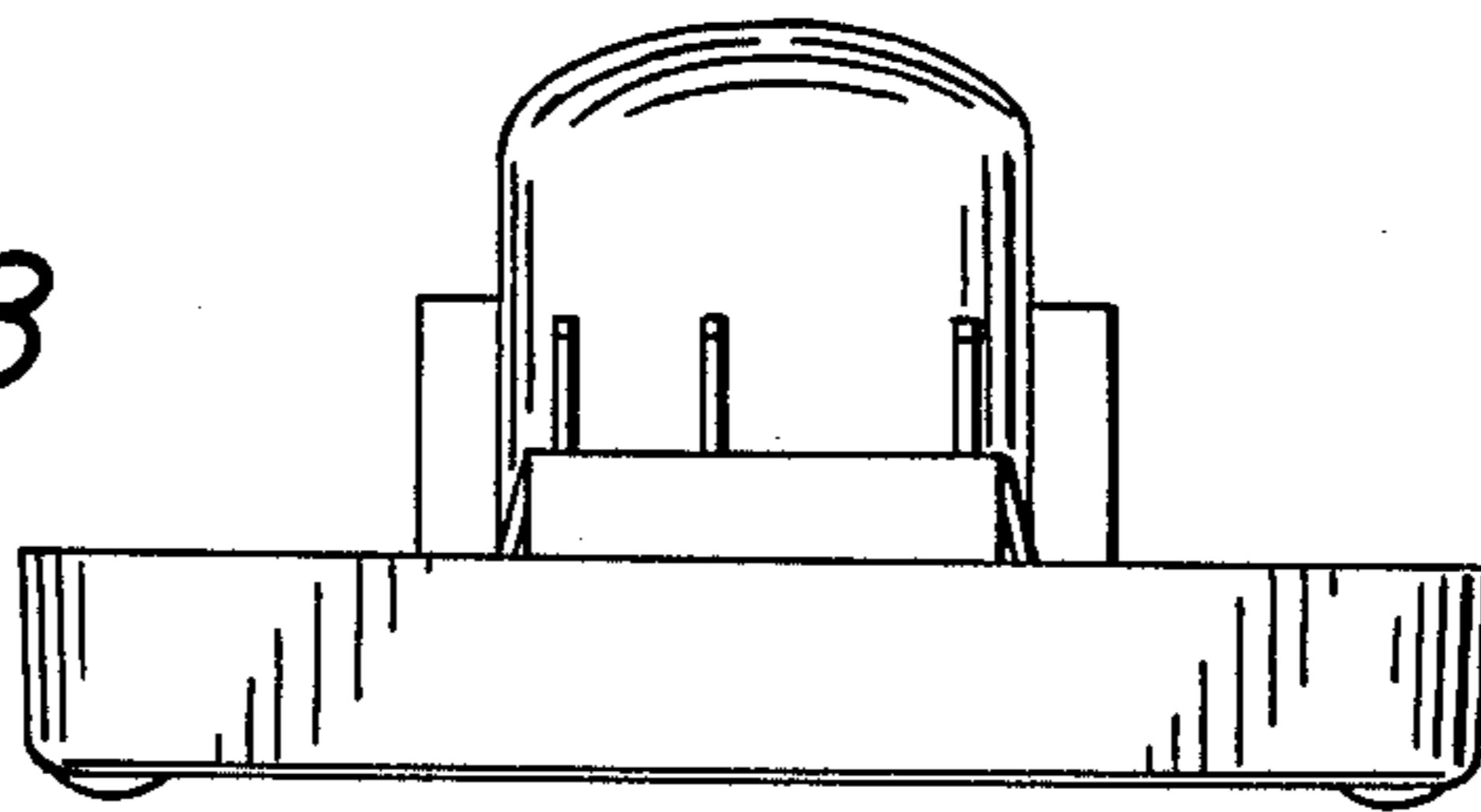
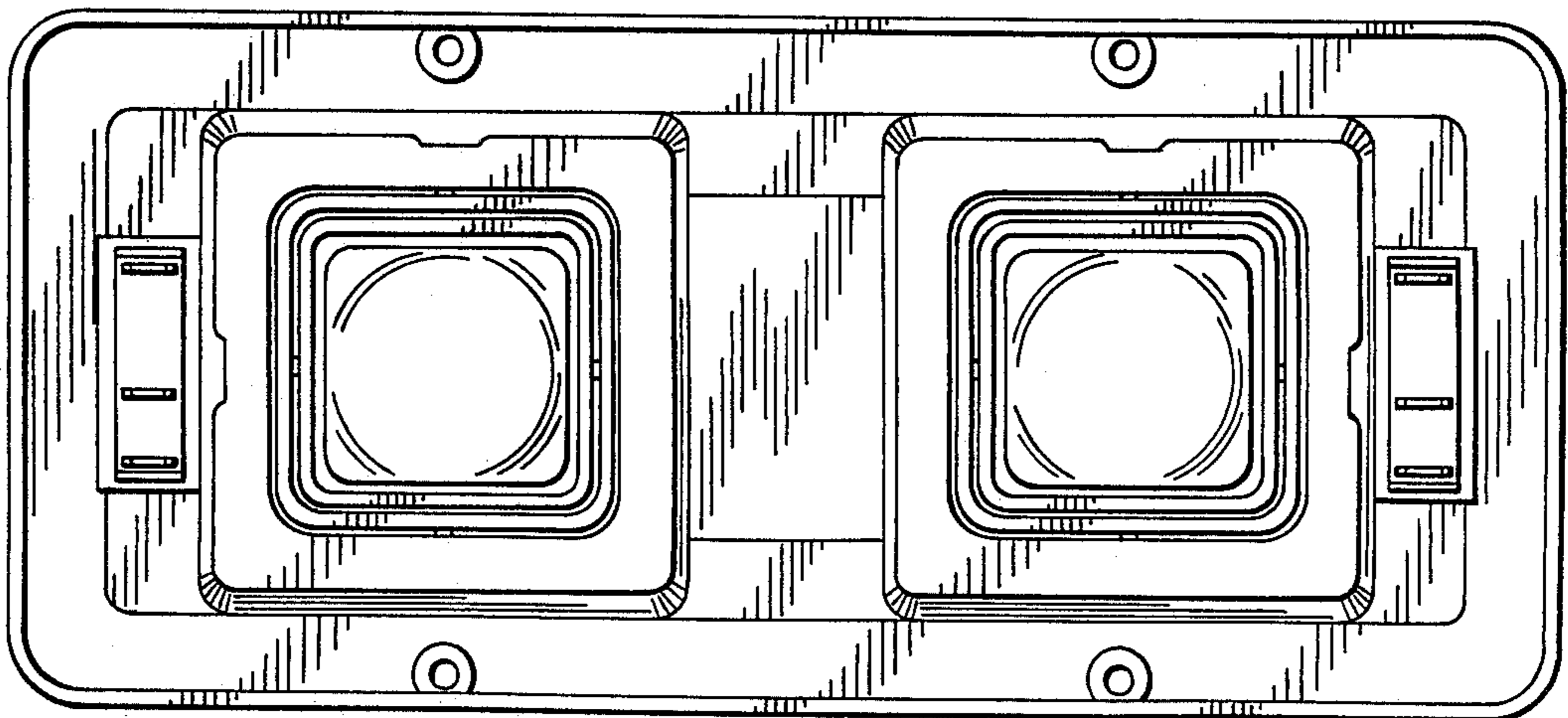

FIG. 4



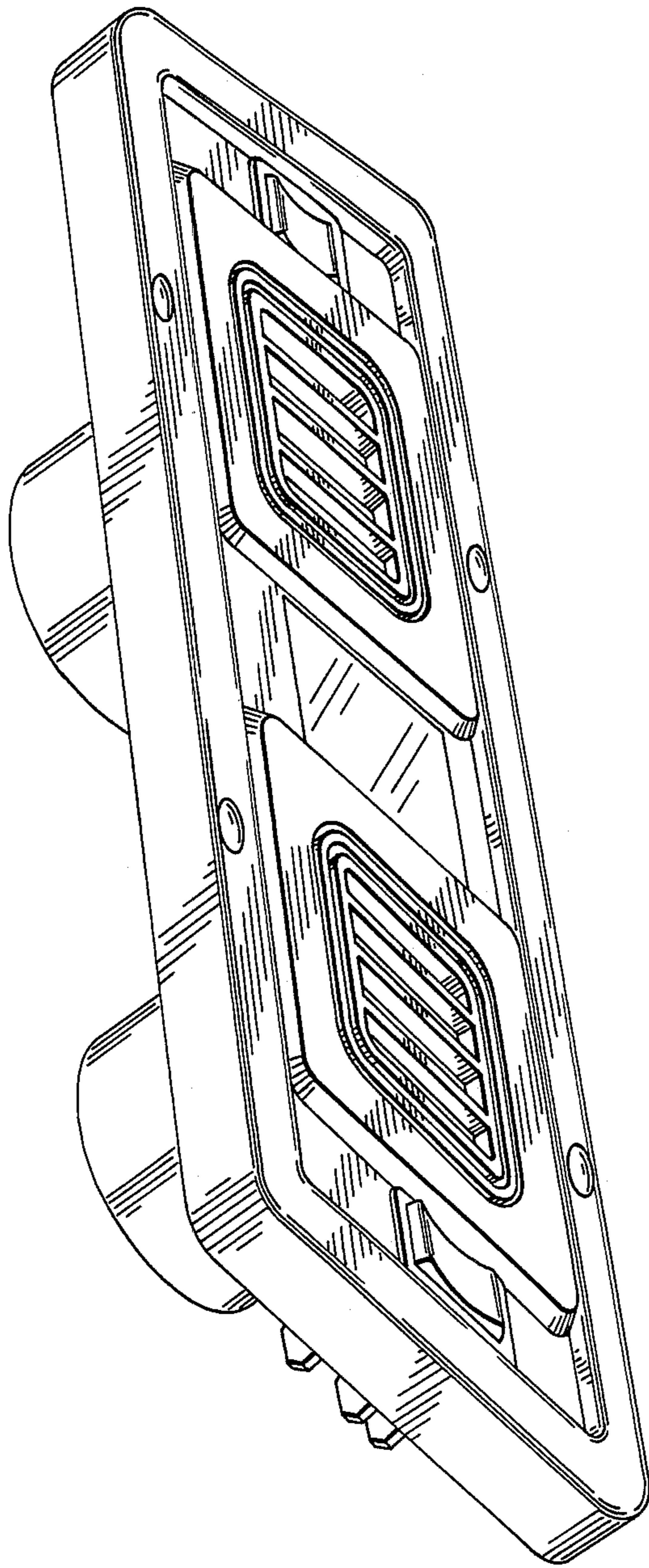

FIG. 5