

- [54] FIREPLACE MANTELPIECE
- [75] Inventor: Vance R. Smith, Brookfield, Vt.
- [73] Assignee: Vermont Castings, Inc., Randolph, Vt.
- [\*\*] Term: 14 Years
- [21] Appl. No.: 875,363
- [22] Filed: Jun. 12, 1986
- [52] U.S. Cl. .... D23/404
- [58] Field of Search ..... D23/314, 343-350, D23/403-406; 126/58, 60-66, 85 R, 126, 138-144, 152, 164-165, 190, 200, 198; 52/36

- [56] **References Cited**
- U.S. PATENT DOCUMENTS**
- D. 108,008 1/1938 Baum ..... D23/404
- D. 108,148 1/1938 Baum ..... D23/404
- D. 280,127 8/1985 Syme et al. .... D23/345

**OTHER PUBLICATIONS**

Squire Stoves brochure (Mar. 1985), Fireplace Mantel.

The Fireplace Mantel Shop catalogue (1979), p. 4, "The Kensington", model D-118.  
Bennet Ireland catalogue (1980), p. 28-Fireplace.

*Primary Examiner*—Wallace R. Burke  
*Assistant Examiner*—Brian N. Vinson  
*Attorney, Agent, or Firm*—Wolf, Greenfield & Sacks

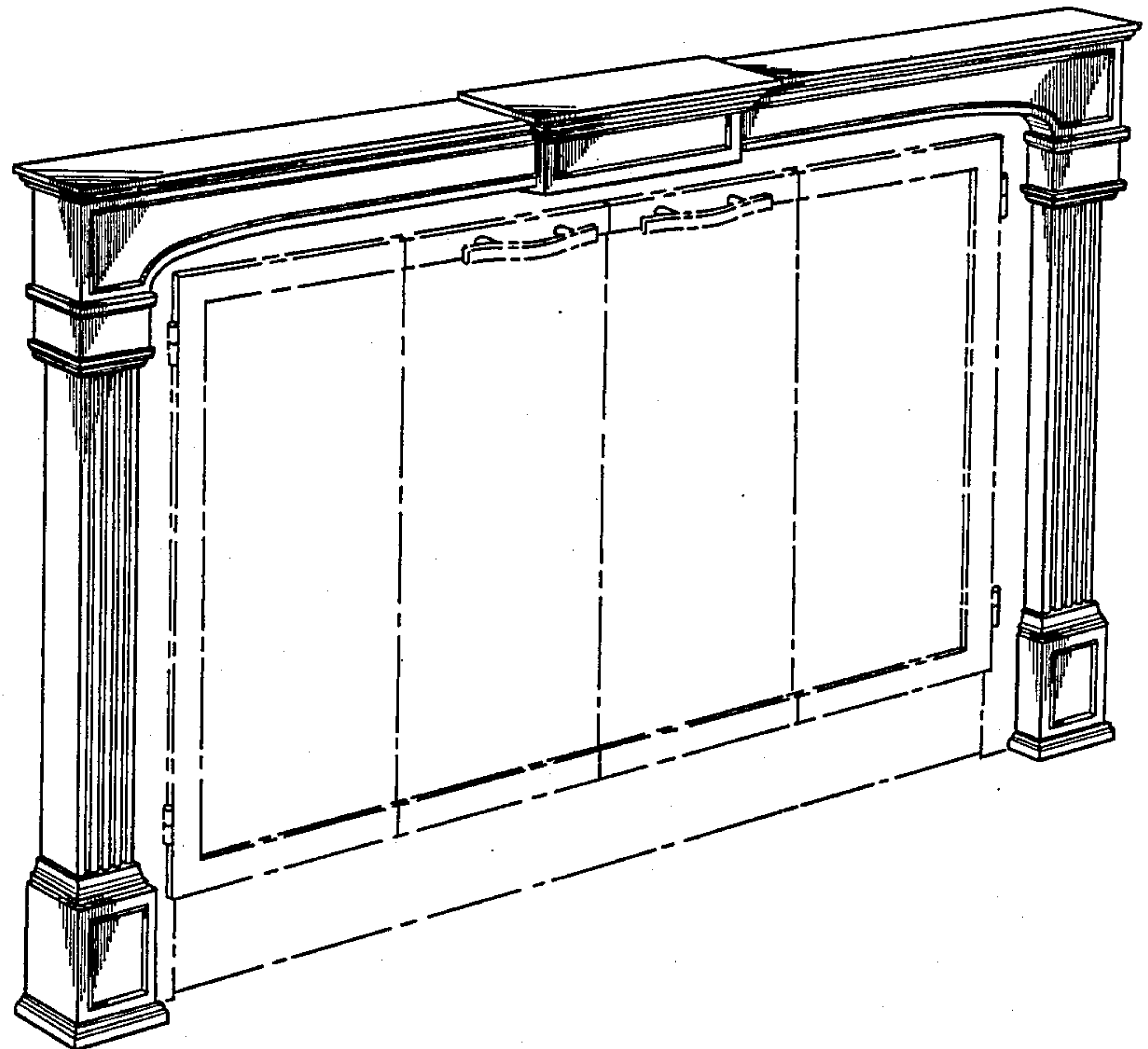
[57] **CLAIM**

The ornamental design for a fireplace mantelpiece, as shown and described.

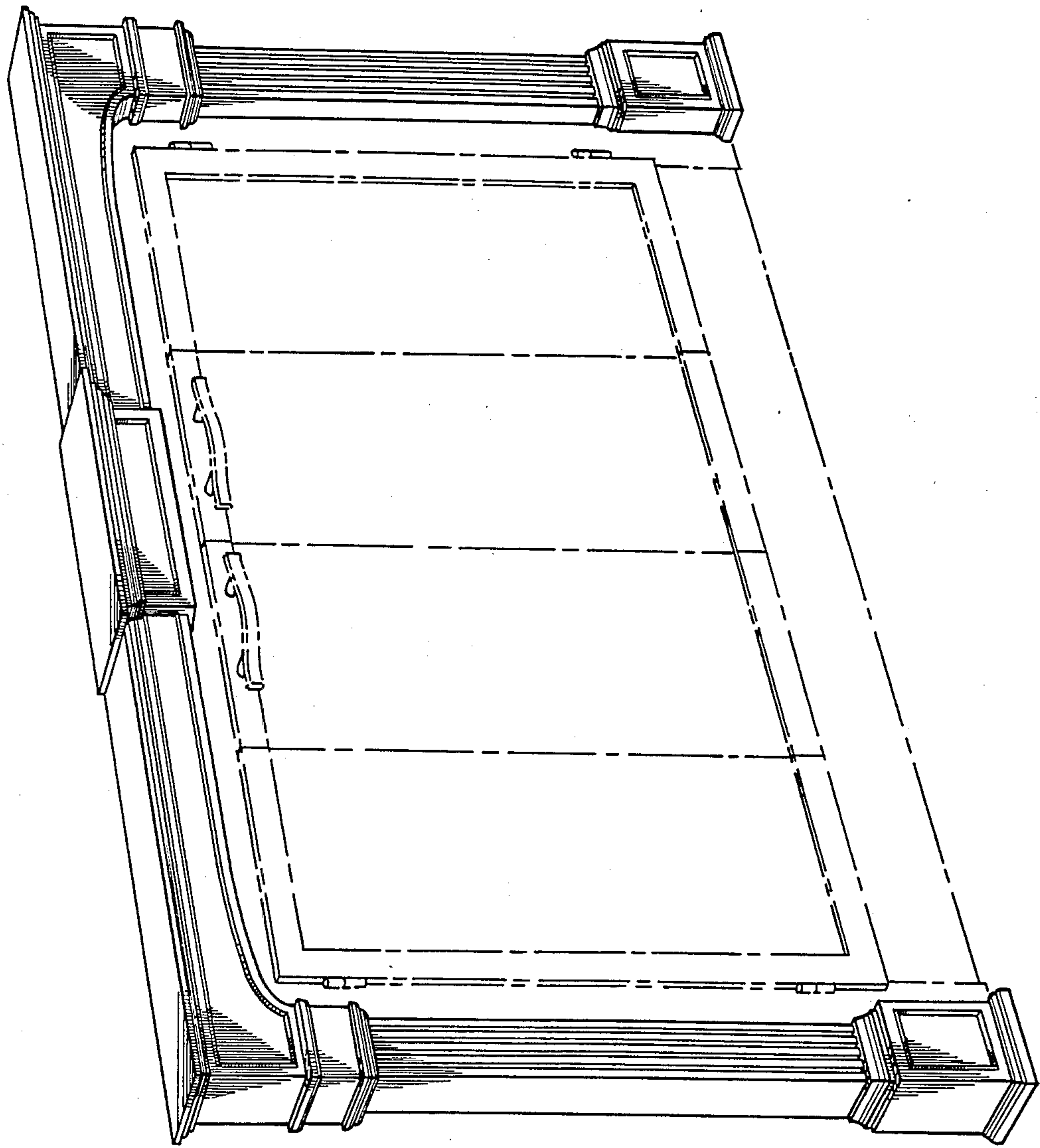
**DESCRIPTION**

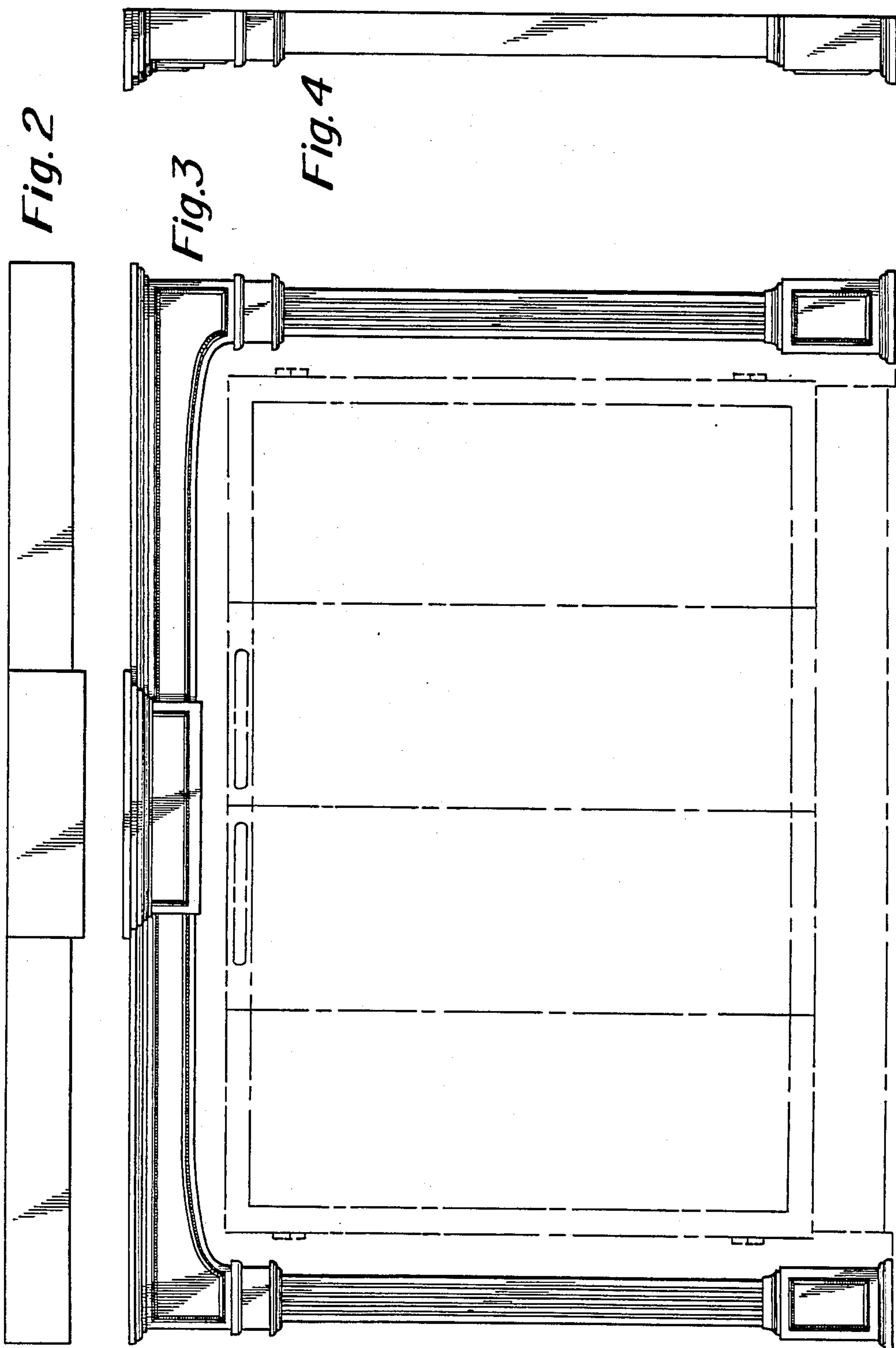
FIG. 1 is a perspective view of a fireplace mantelpiece showing my new design;  
FIG. 2 is a top plan view thereof;  
FIG. 3 is a front elevational view thereof;  
FIG. 4 is a right side elevational view thereof, the left side being a mirror image of that shown;  
FIG. 5 is a rear elevational view thereof; and  
FIG. 6 is a bottom plan view thereof.

The broken-line showing of the fire screen doors in FIGS. 1 and 3 is for illustrative purposes only and forms no part of the claimed design.

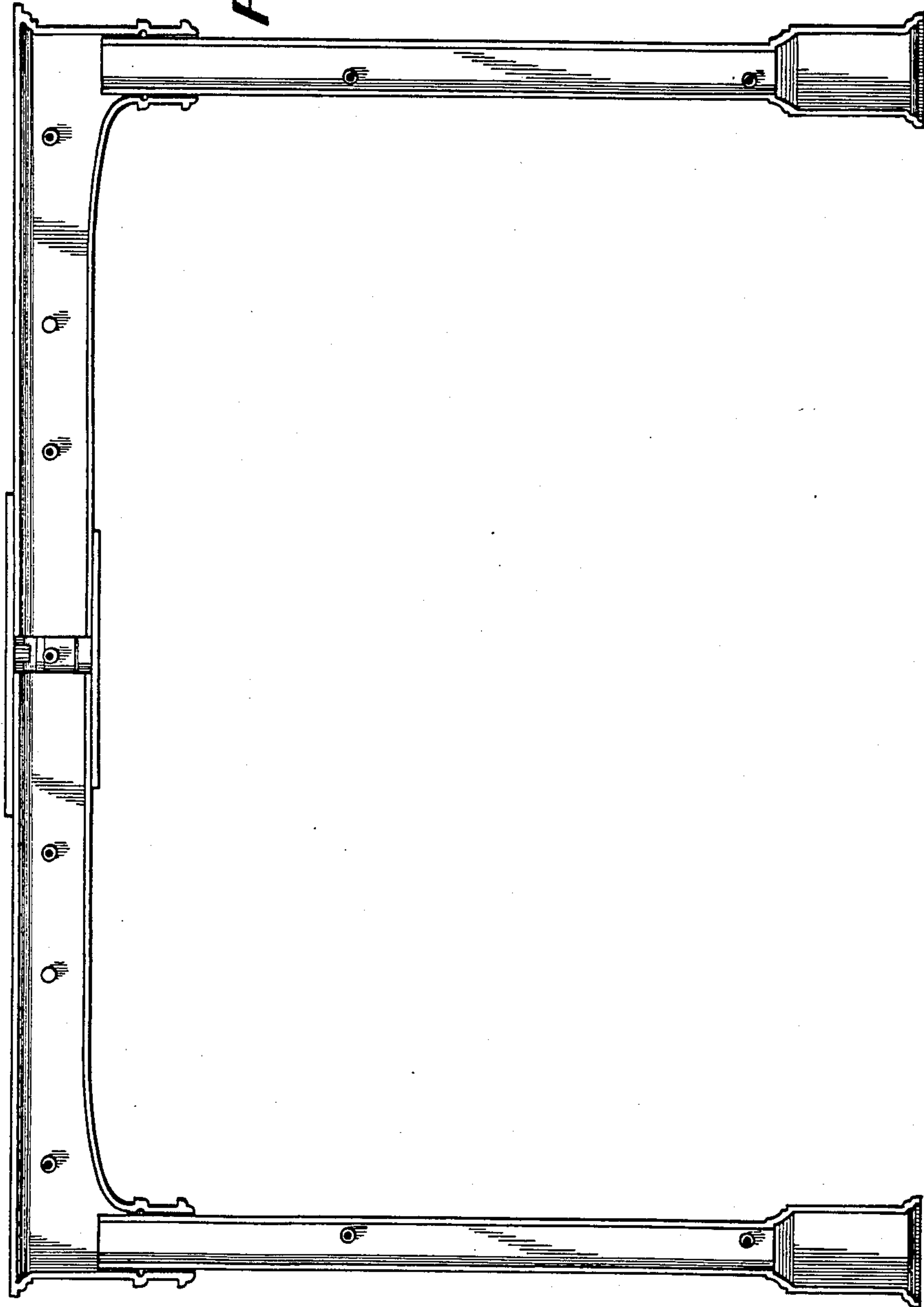


*Fig. 1*





*Fig. 5*



*Fig. 6*

