

[54] COMBINED GARMENT BAG AND LUGGAGE PIECE

[75] Inventors: William L. King, Denver, Colo.; Charles K. Weisbart, Mequon, Wis.

[73] Assignee: Samsonite Corporation, Denver, Colo.

[\*\*] Term: 14 Years

[21] Appl. No.: 834,069

[22] Filed: Feb. 19, 1986

[52] U.S. Cl. .... D3/71

[58] Field of Search ..... D3/71, 76, 77; 150/101, 150/104, 107, 108, 138

[56] References Cited

U.S. PATENT DOCUMENTS

D. 264,267	5/1982	Stark	.....	D3/71
D. 267,522	1/1983	Stark	.....	D3/71
D. 270,873	10/1983	Katz et al.	.....	D3/74
D. 270,970	10/1983	Katz et al.	.....	D3/74 X
4,257,463	3/1981	Monaco	.....	D3/71 X

Primary Examiner—Bruce W. Dunkins  
Assistant Examiner—Yvonne Brunot  
Attorney, Agent, or Firm—Gary M. Polumbus

[57] CLAIM

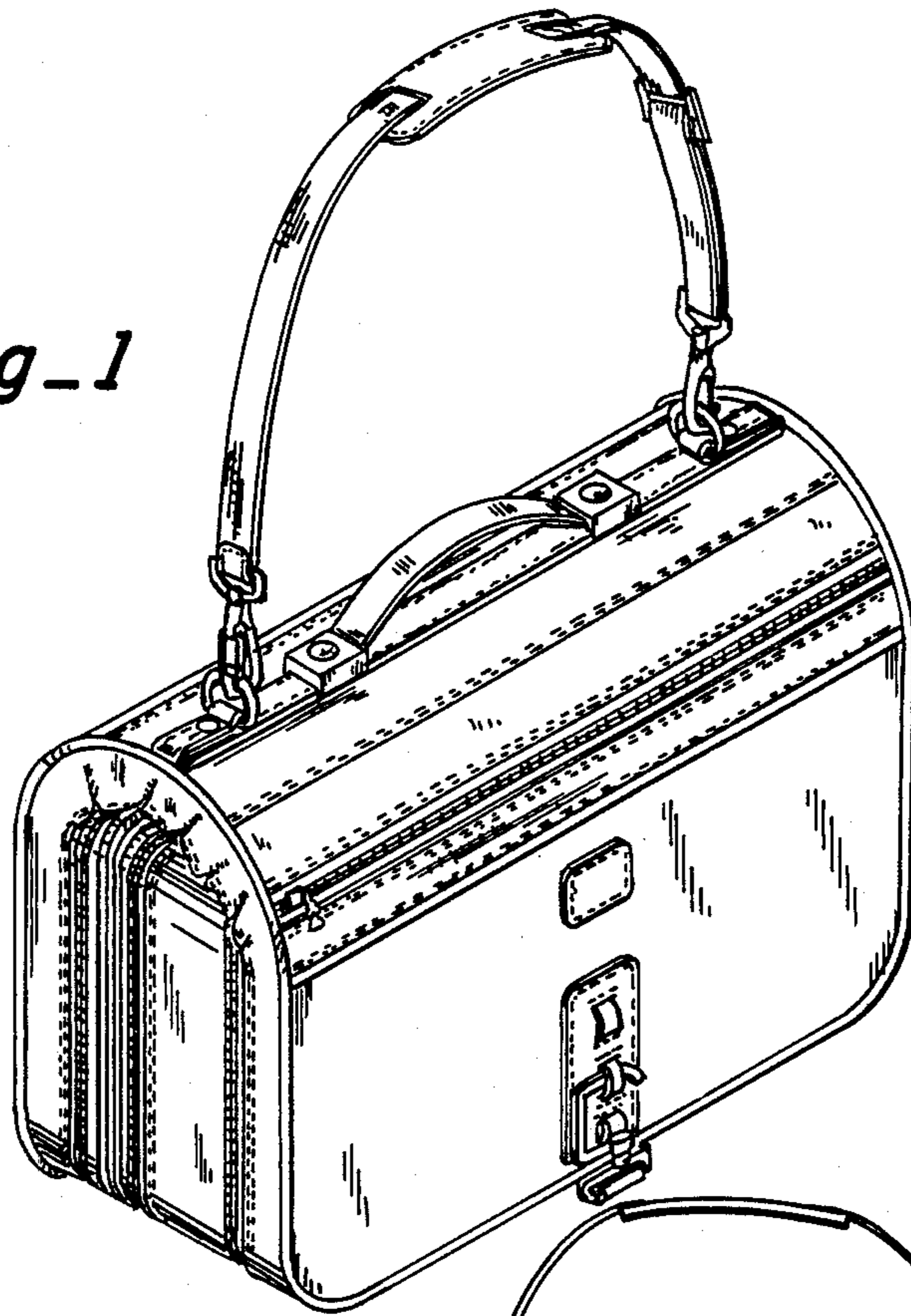
The ornamental design for a combined garment bag and luggage piece, as shown and described.

DESCRIPTION

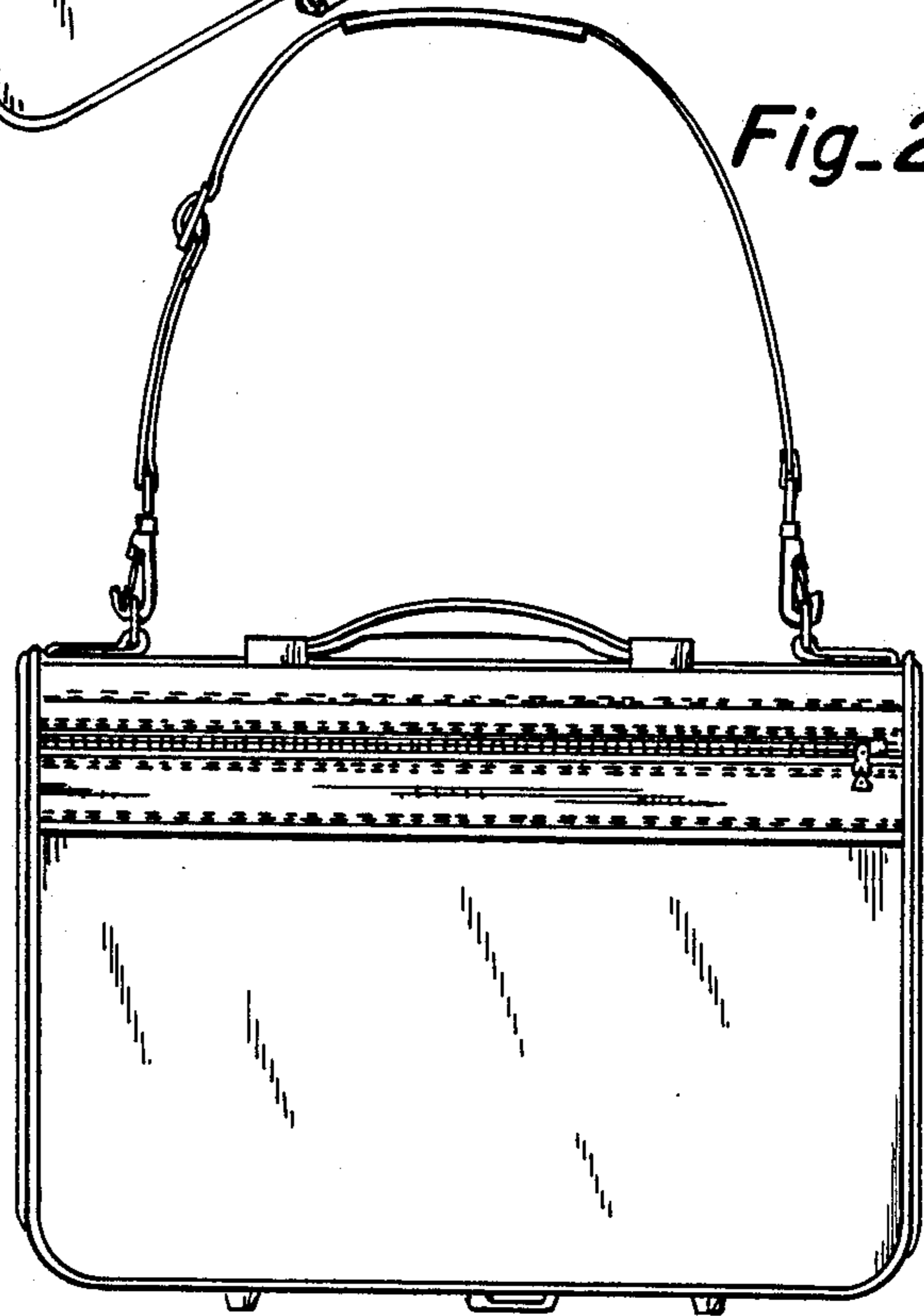
FIG. 1 is a perspective view of a combined garment bag and luggage piece embodying our new design. FIG. 2 is a rear side elevational view thereof. FIG. 3 is a left-end elevational view thereof. FIG. 4 is a front side elevational view thereof. FIG. 5 is a right-hand end elevational view thereof. FIG. 6 is a top plan view thereof. FIG. 7 is a bottom plan view thereof. FIG. 8 is a top front perspective view thereof illustrating the combined garment bag and luggage piece in an open configuration. FIG. 9 is a bottom rear perspective view thereof illustrating the combined garment bag and luggage piece in the open configuration. FIG. 10 is a perspective view of a combined garment bag and luggage piece showing a second embodiment of our design. FIG. 11 is a rear side elevational view thereof. FIG. 12 is a left-end elevational view thereof. FIG. 13 is a front side elevational view thereof. FIG. 14 is a right-hand end elevational view thereof. FIG. 15 is a top plan view thereof. FIG. 16 is a bottom plan view thereof. FIG. 17 is a top front perspective view illustrating the alternative design embodiment of the combined garment bag and luggage piece in an open configuration. FIG. 18 is a bottom rear perspective view illustrating the alternative design embodiment of the combined garment bag and luggage piece in the open configuration.



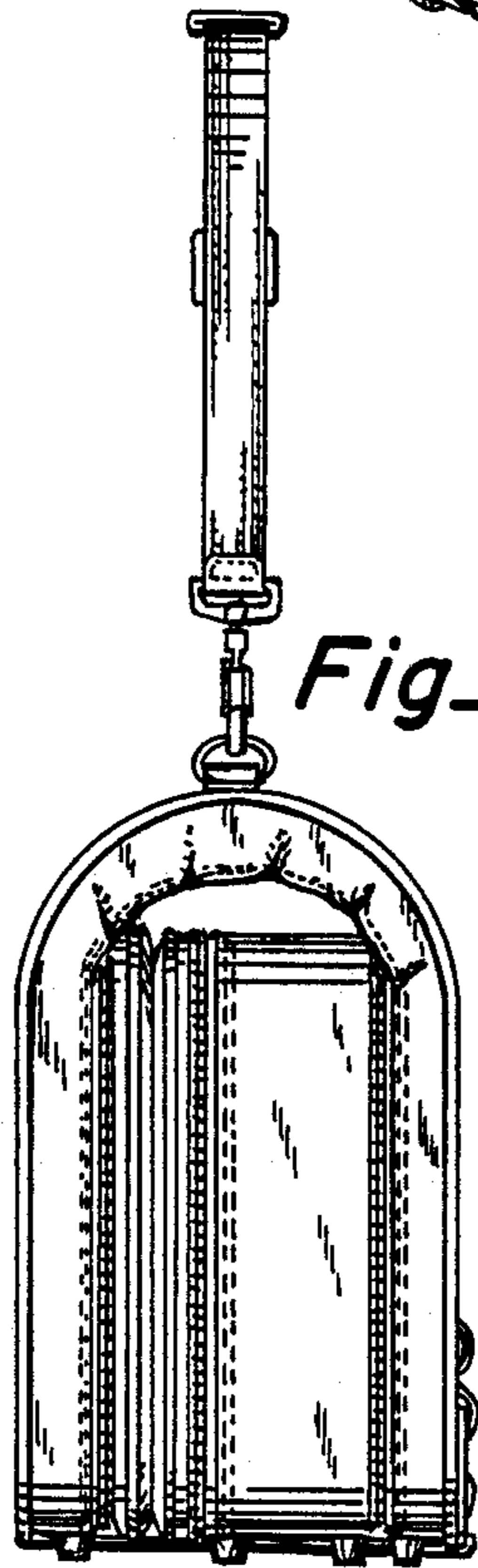
*Fig\_1*

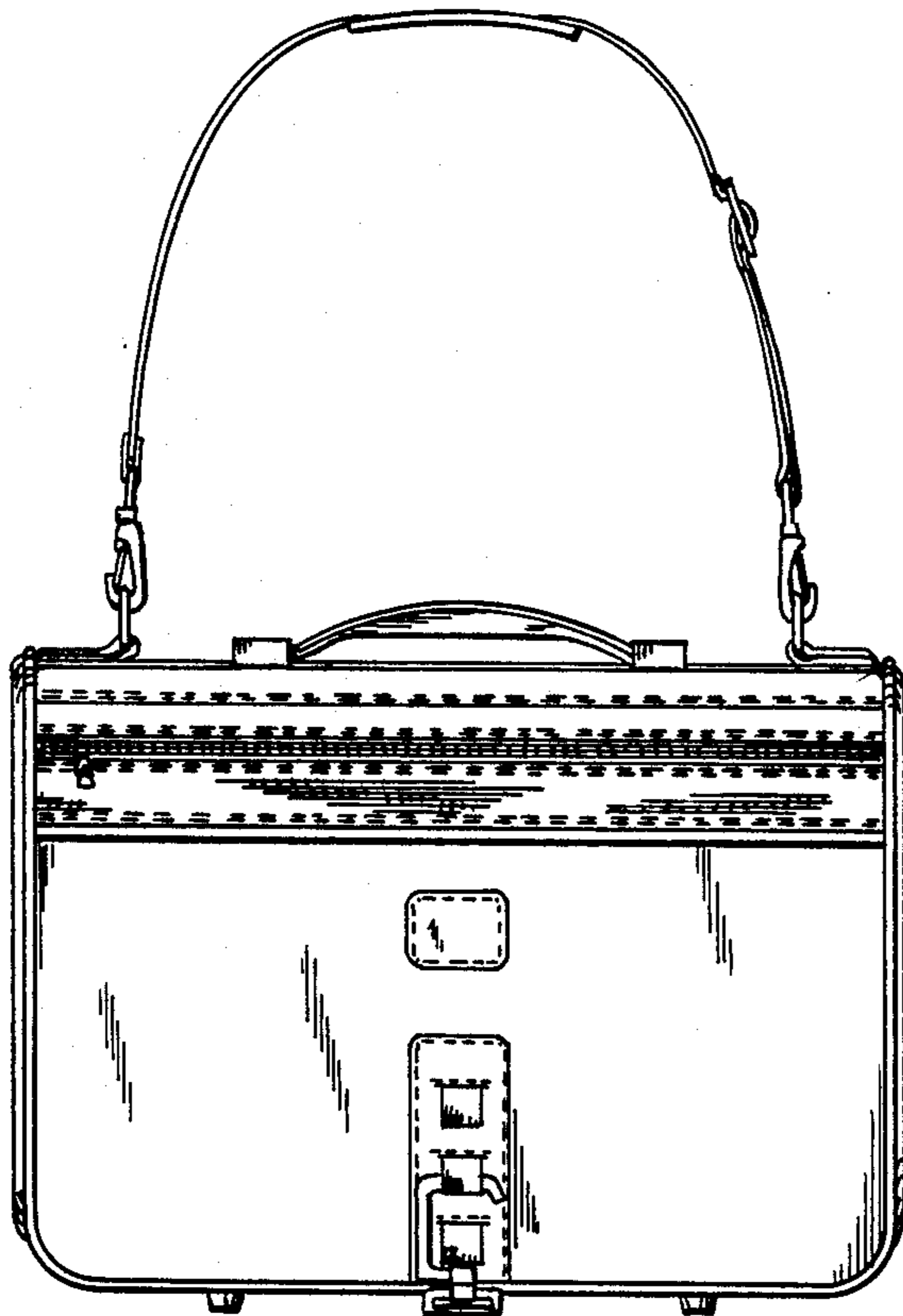


*Fig\_2*

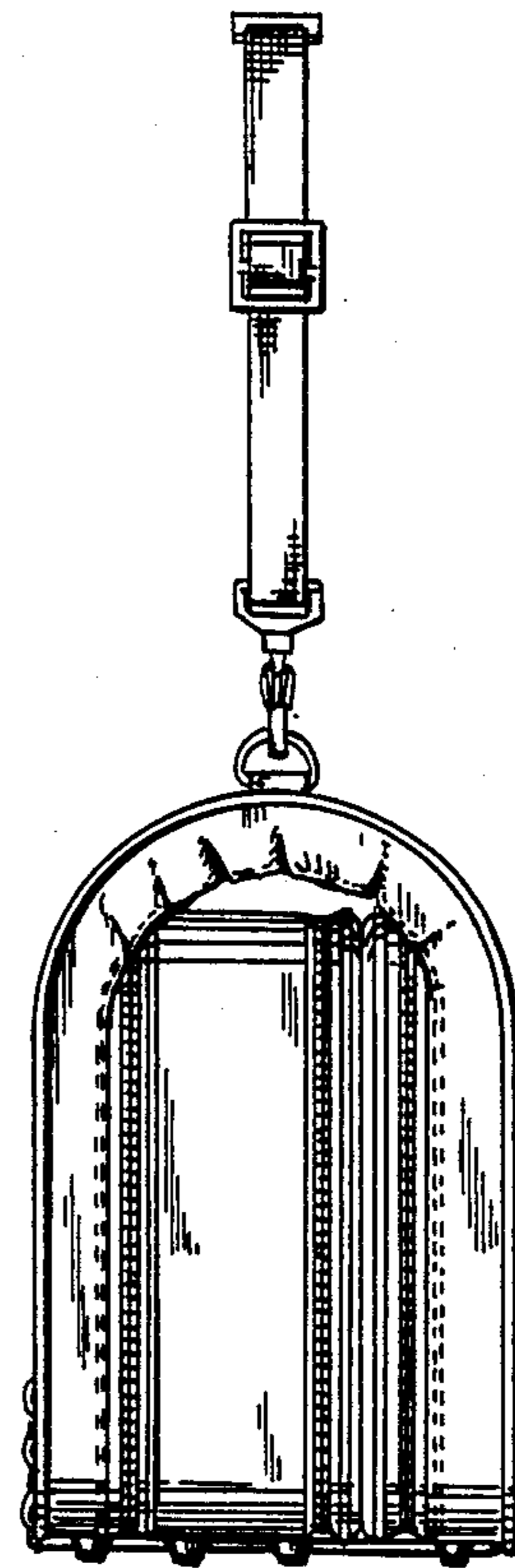


*Fig\_3*

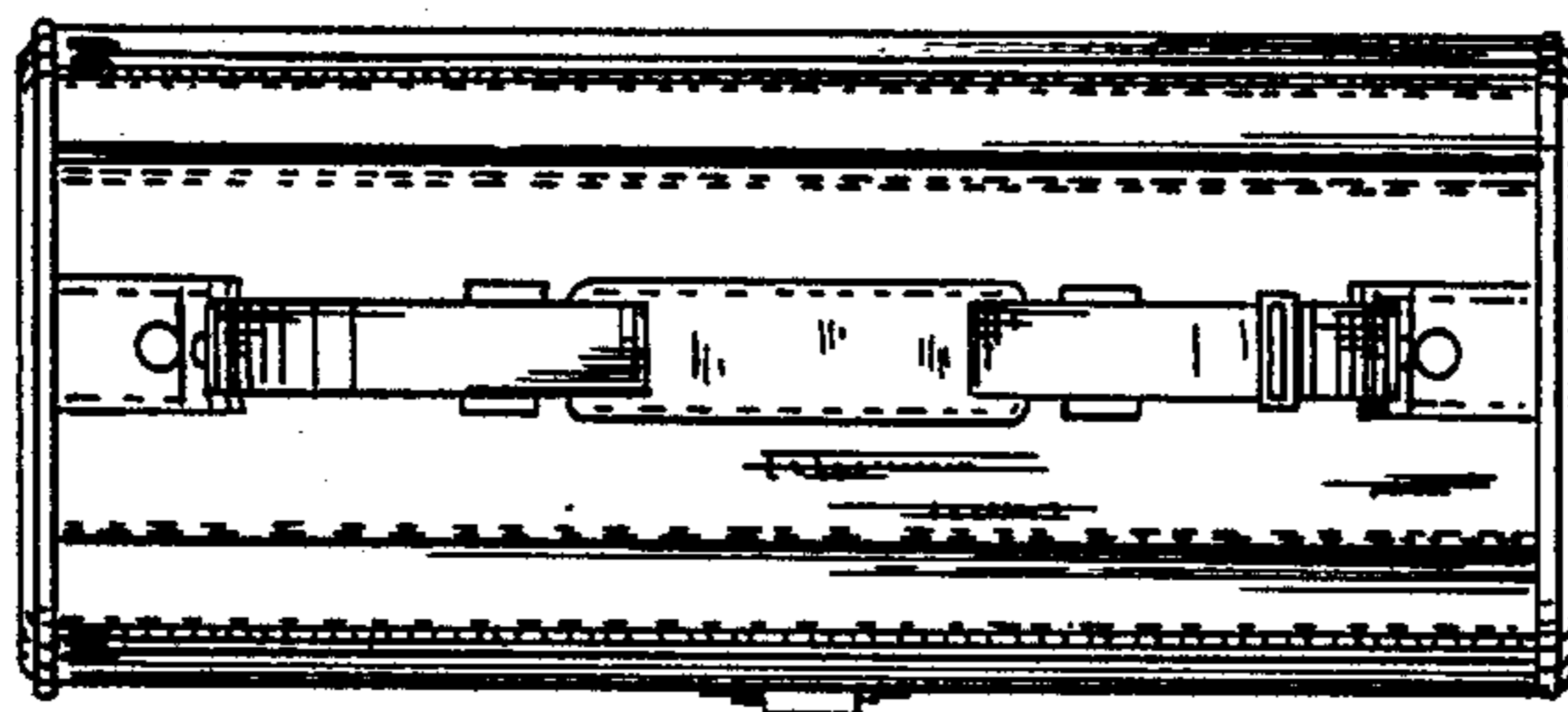




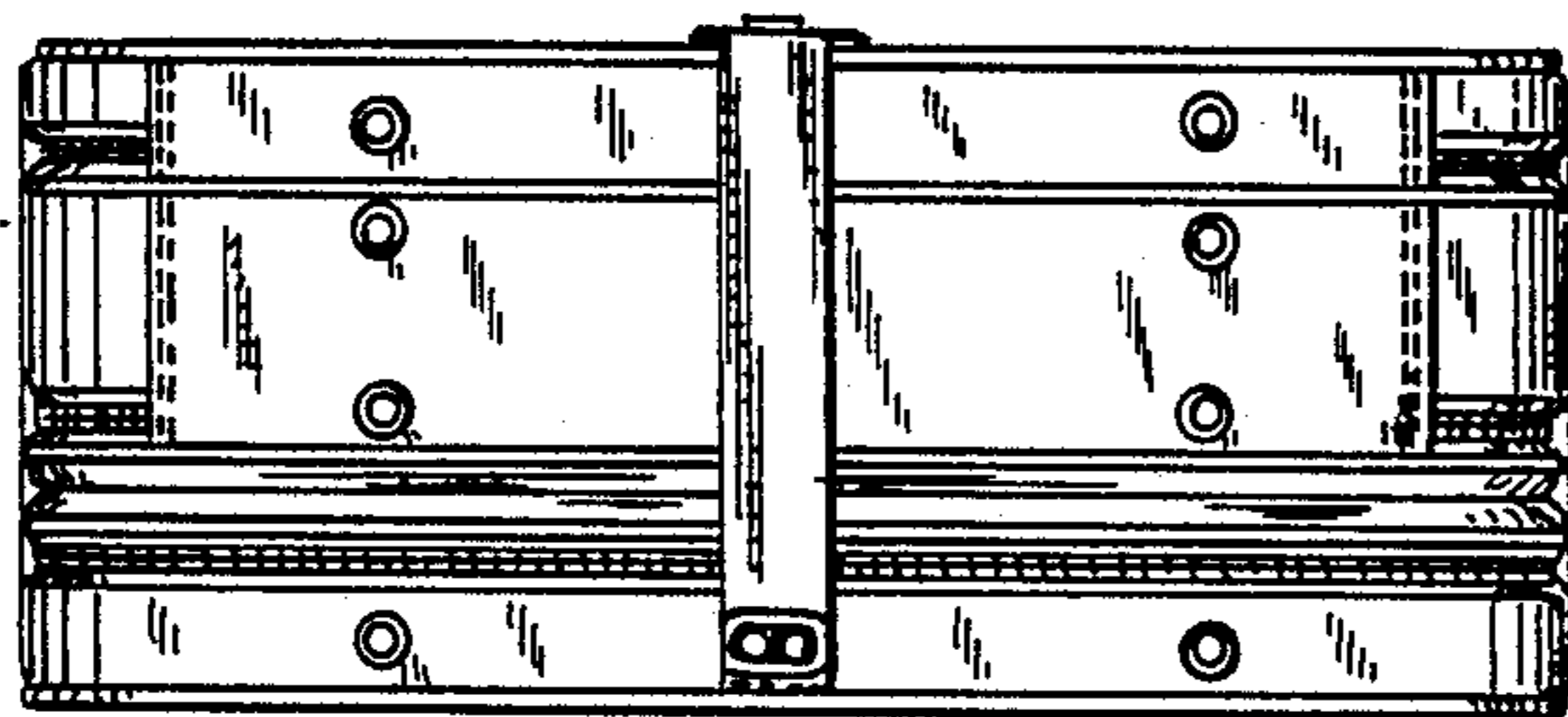
Fig\_4



Fig\_5

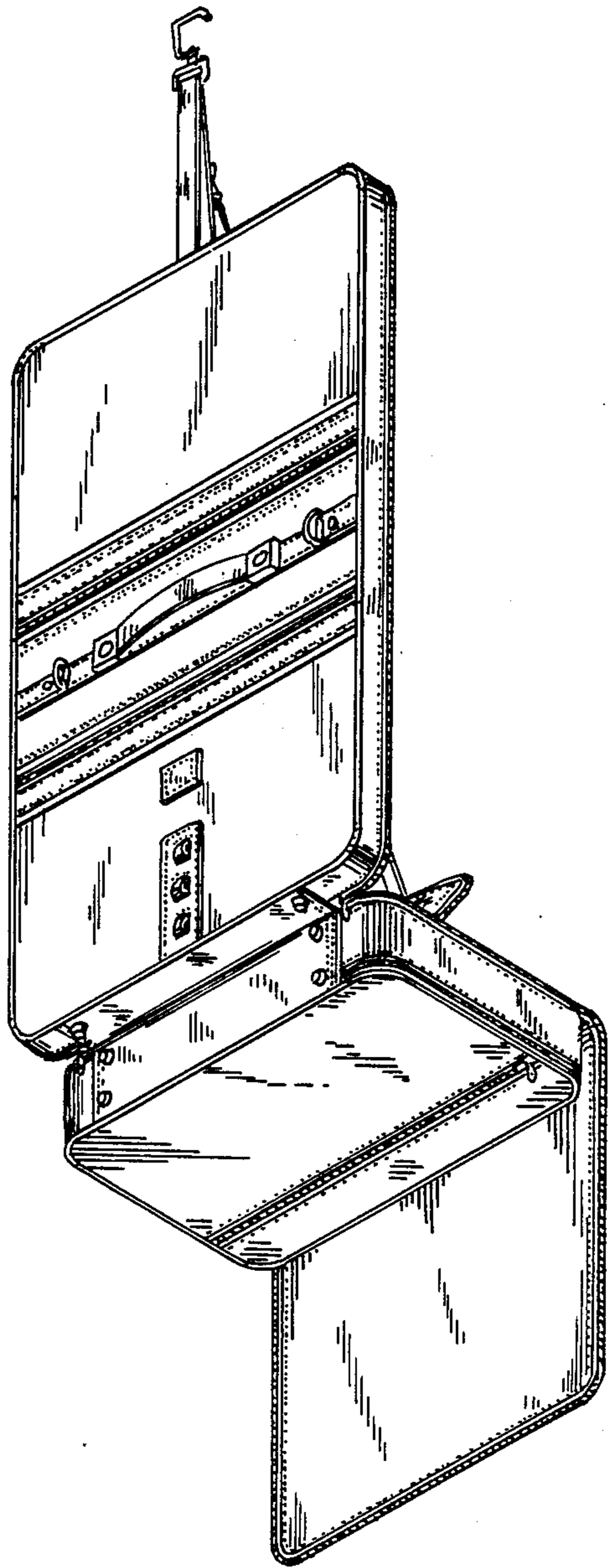
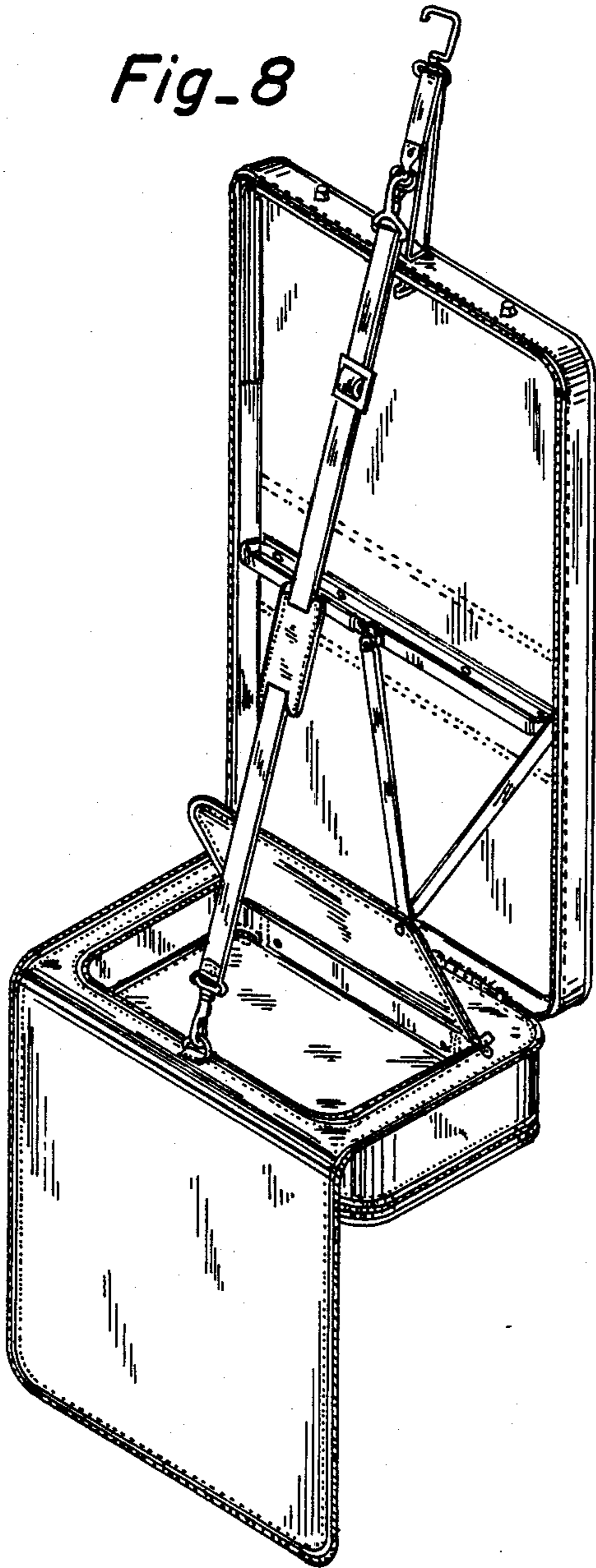


Fig\_6



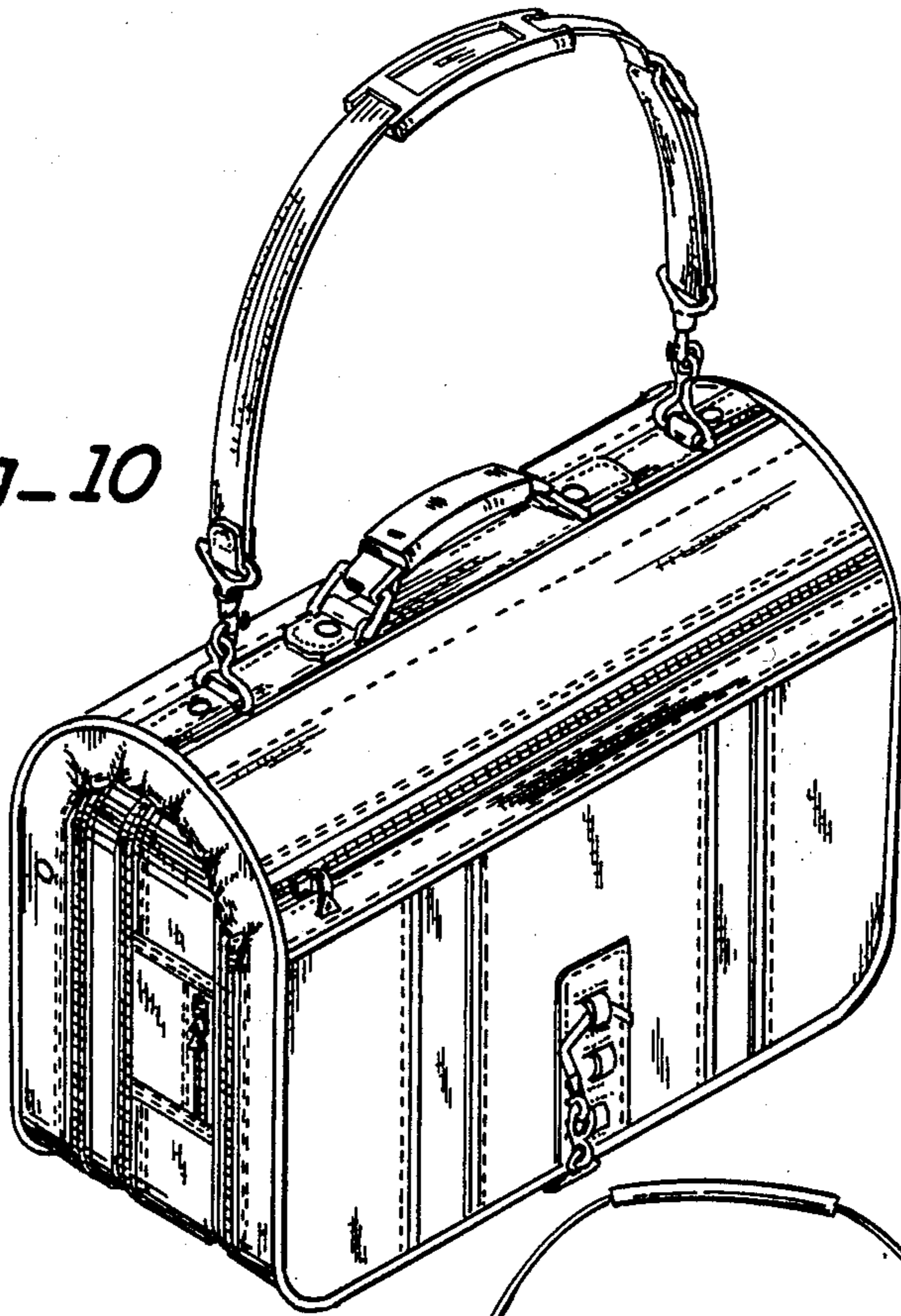
Fig\_7

*Fig-8*

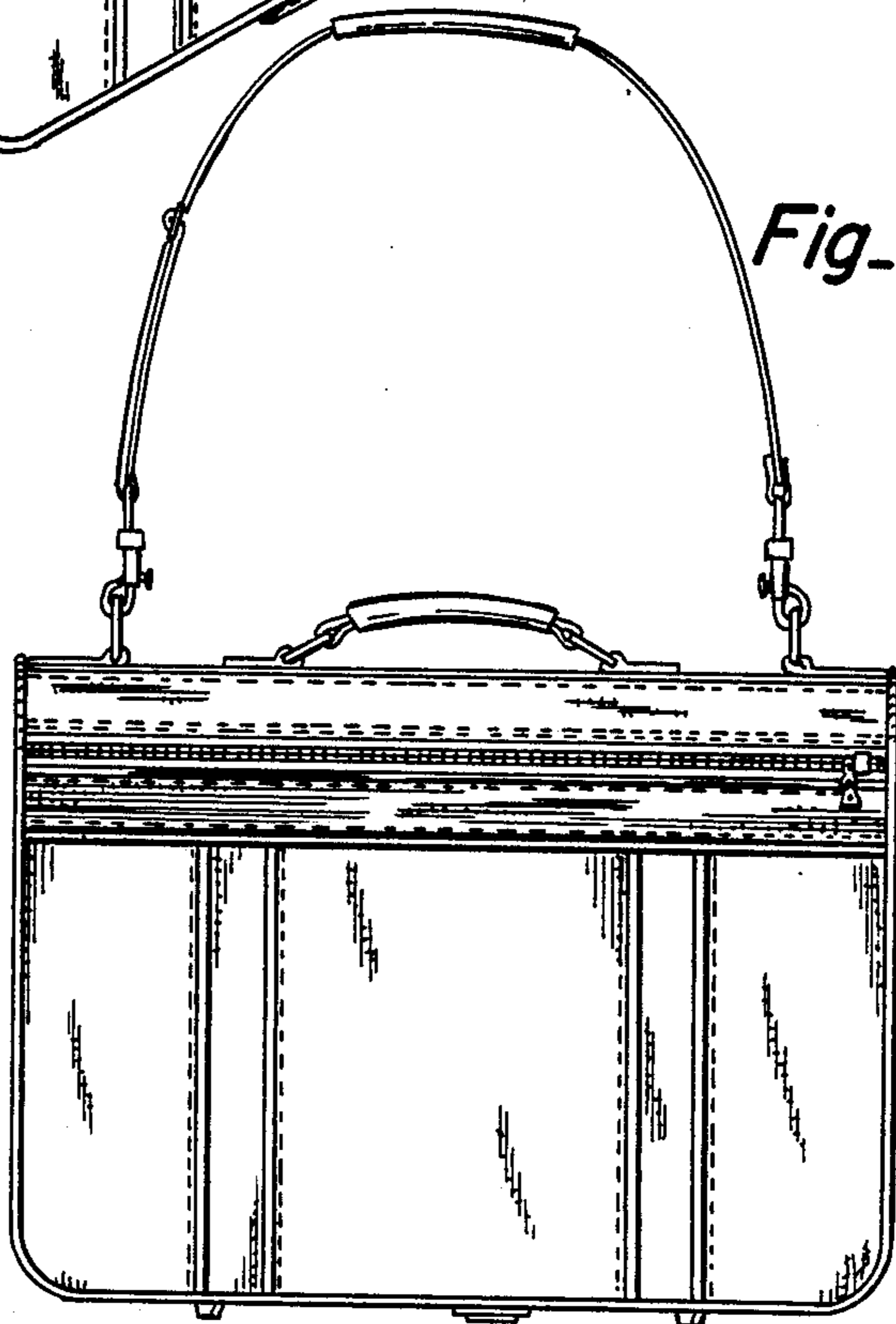


*Fig-9*

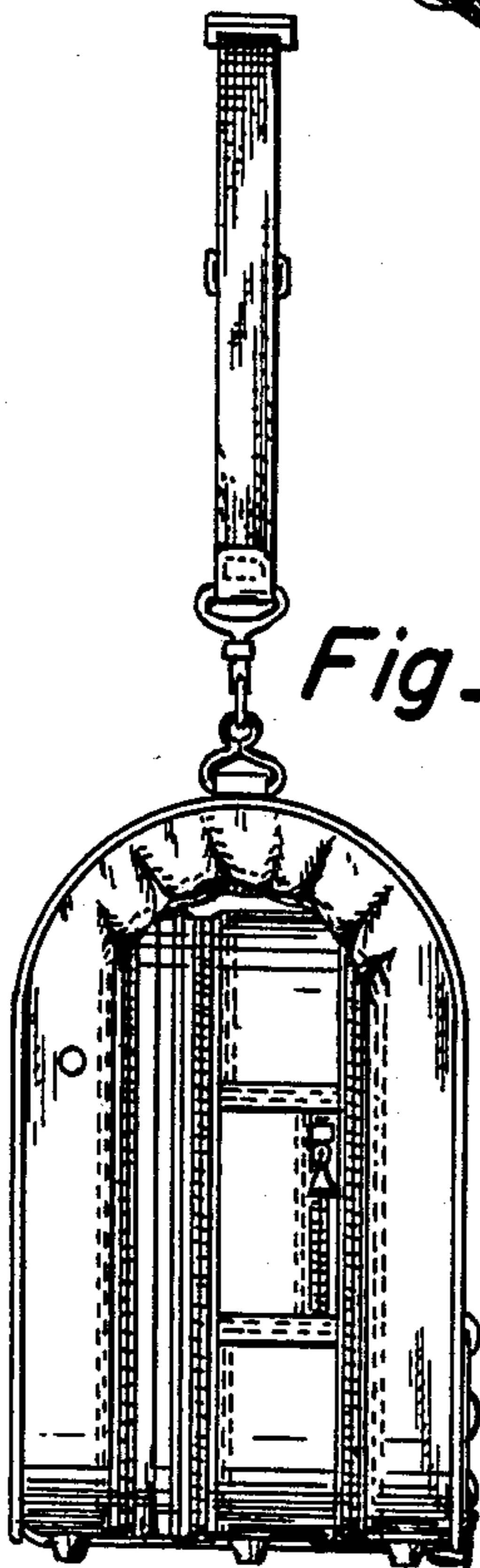
*Fig\_10*

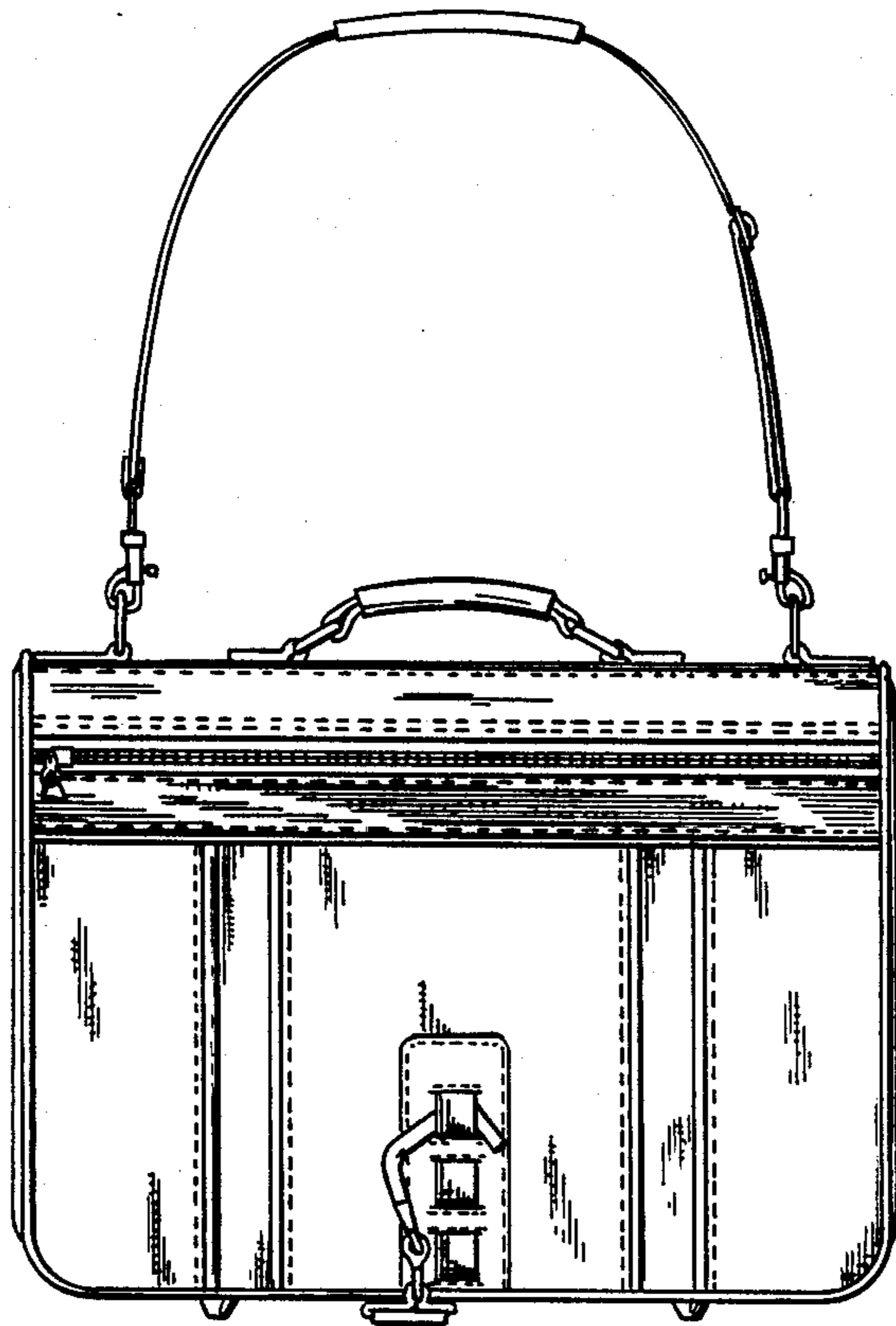


*Fig\_11*

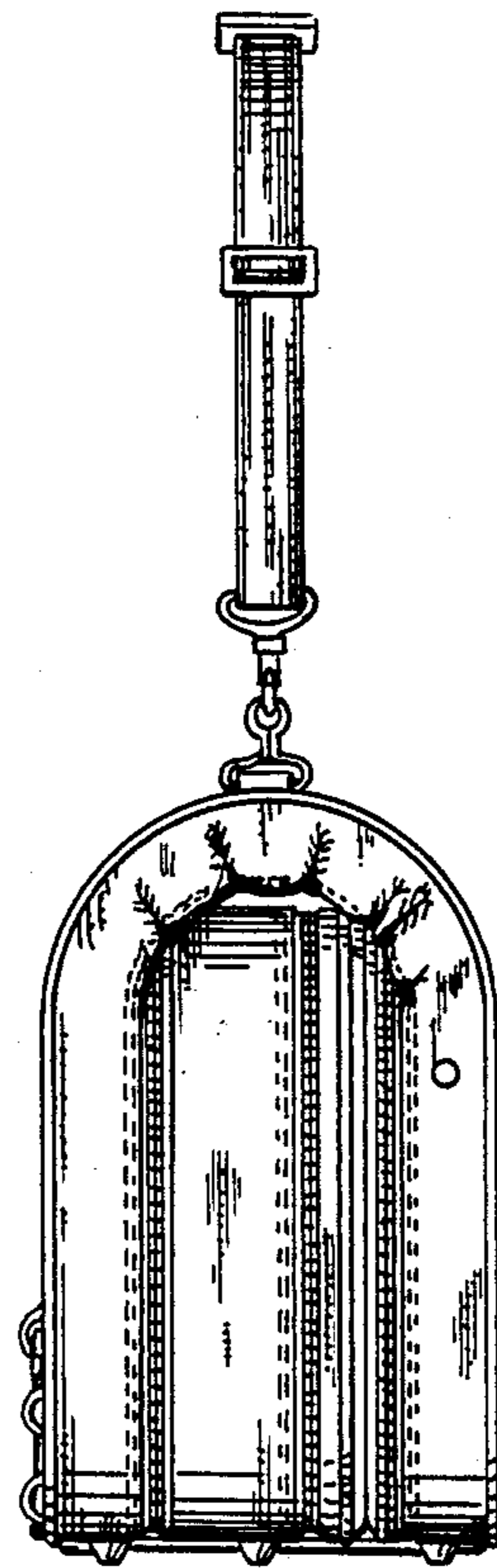


*Fig\_12*

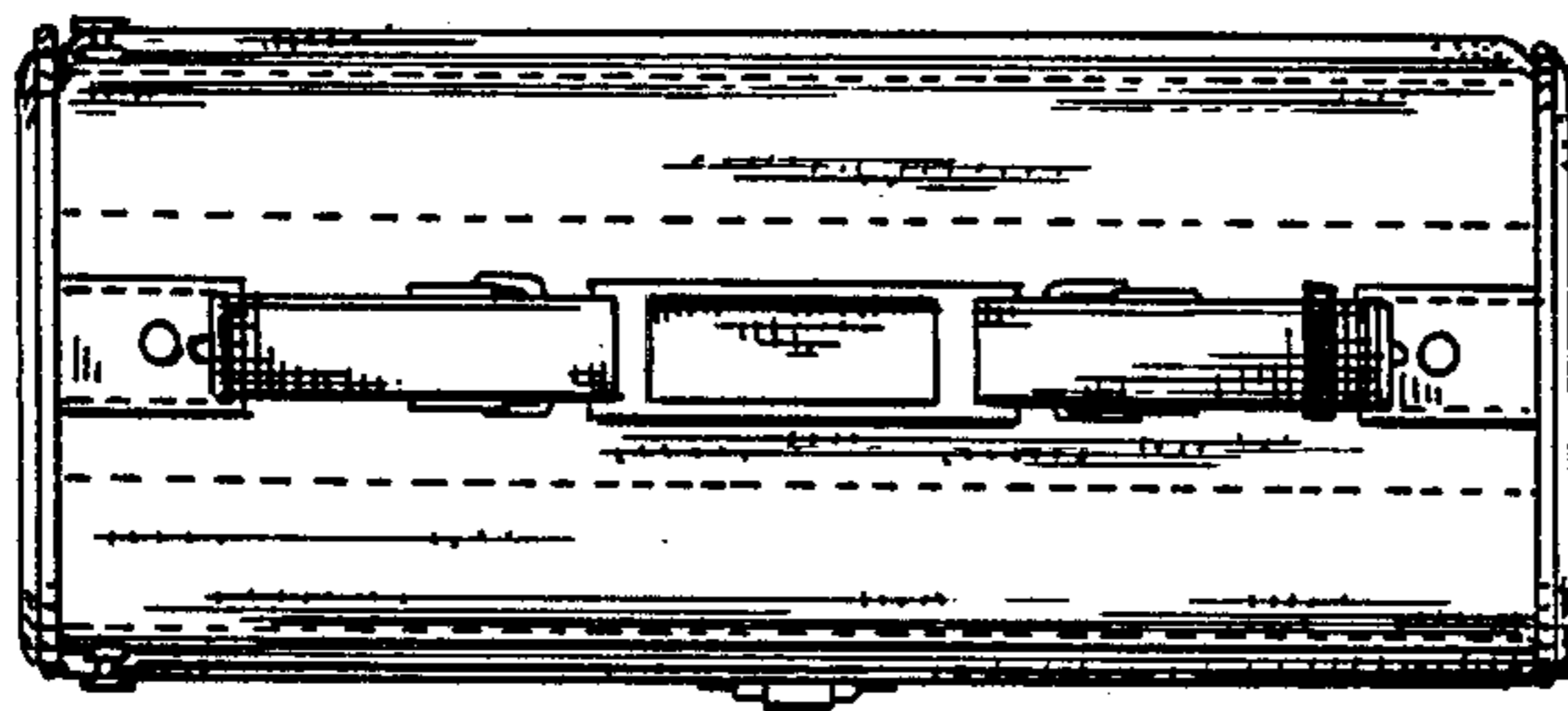




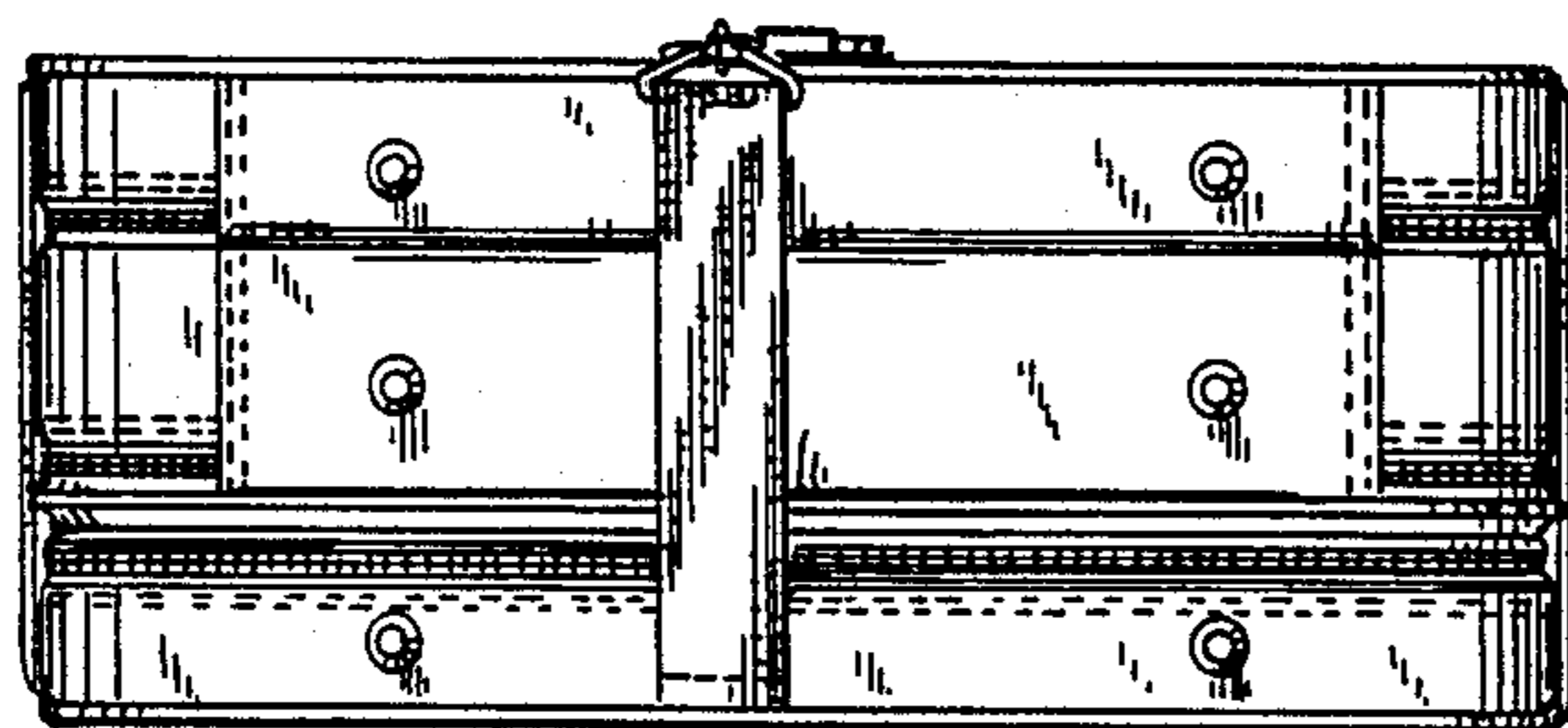
Fig\_13



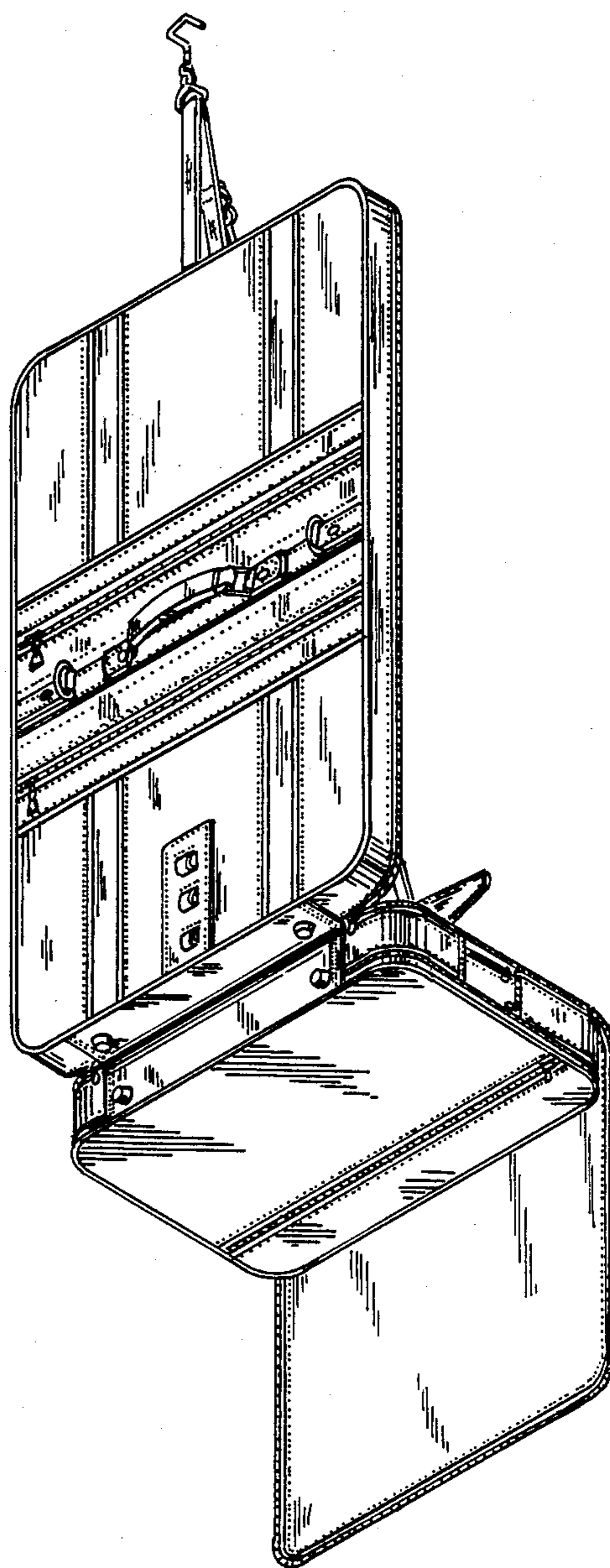
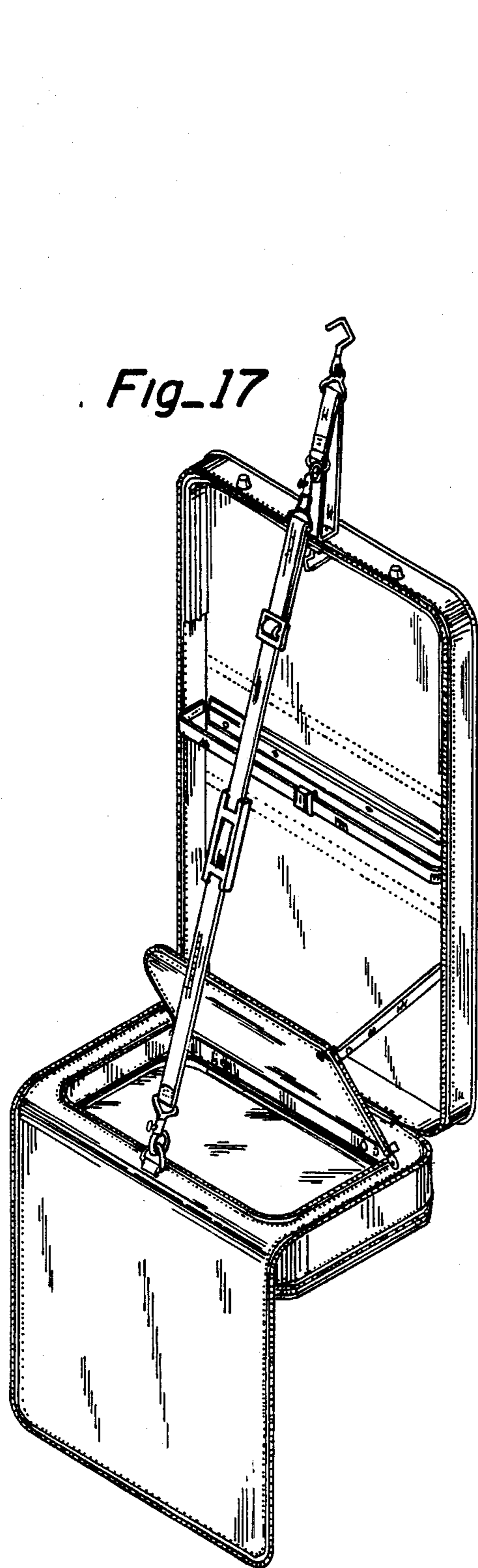
Fig\_14



Fig\_15



Fig\_16



*Fig\_18*