

[54] JACK

[75] Inventor: Richard T. Plummer, Atlanta, Ga.

[73] Assignee: Thunder Point Company, Atlanta, Ga.

[**] Term: 14 Years

[21] Appl. No.: 896,004

[22] Filed: Aug. 13, 1986

[52] U.S. Cl. D34/31

[58] Field of Search D34/28, 31, 32; 254/93 H, 122, 2 R, 94; 248/352

[56] References Cited

U.S. PATENT DOCUMENTS

3,747,951	7/1973	Brown	248/352
4,195,818	4/1980	Grimes	254/94
4,635,833	1/1987	Scarlata	D34/31
4,723,756	2/1988	Stumpf, Jr.	254/93 H
4,741,414	5/1988	Claassen	254/122

FOREIGN PATENT DOCUMENTS

1053638	9/1953	France	254/94
383789	1/1965	Switzerland	254/94

Primary Examiner—Wallace R. Burke
Assistant Examiner—Kay H. Chin
Attorney, Agent, or Firm—Thomas & Kennedy

[57] CLAIM

The ornamental design for a jack, as shown and described.

DESCRIPTION

FIG. 1 is a perspective view of a jack showing my new design, showing the jack mounted to a tractor in a lowered, operative position;
FIG. 2 is a rear elevational view thereof;
FIG. 3 is a front elevational view thereof;
FIG. 4 is a side elevational view thereof, the opposite side elevational view being a mirror image of that shown;
FIG. 5 is a top plan view thereof; and
FIG. 6 is a bottom plan view thereof.
FIG. 7 is a perspective view thereof, showing the jack mounted to a tractor in a raised, stowed position;
The broken lines shown in FIGS. 1 and 7 are for illustration purposes only and form no part of the claimed design.

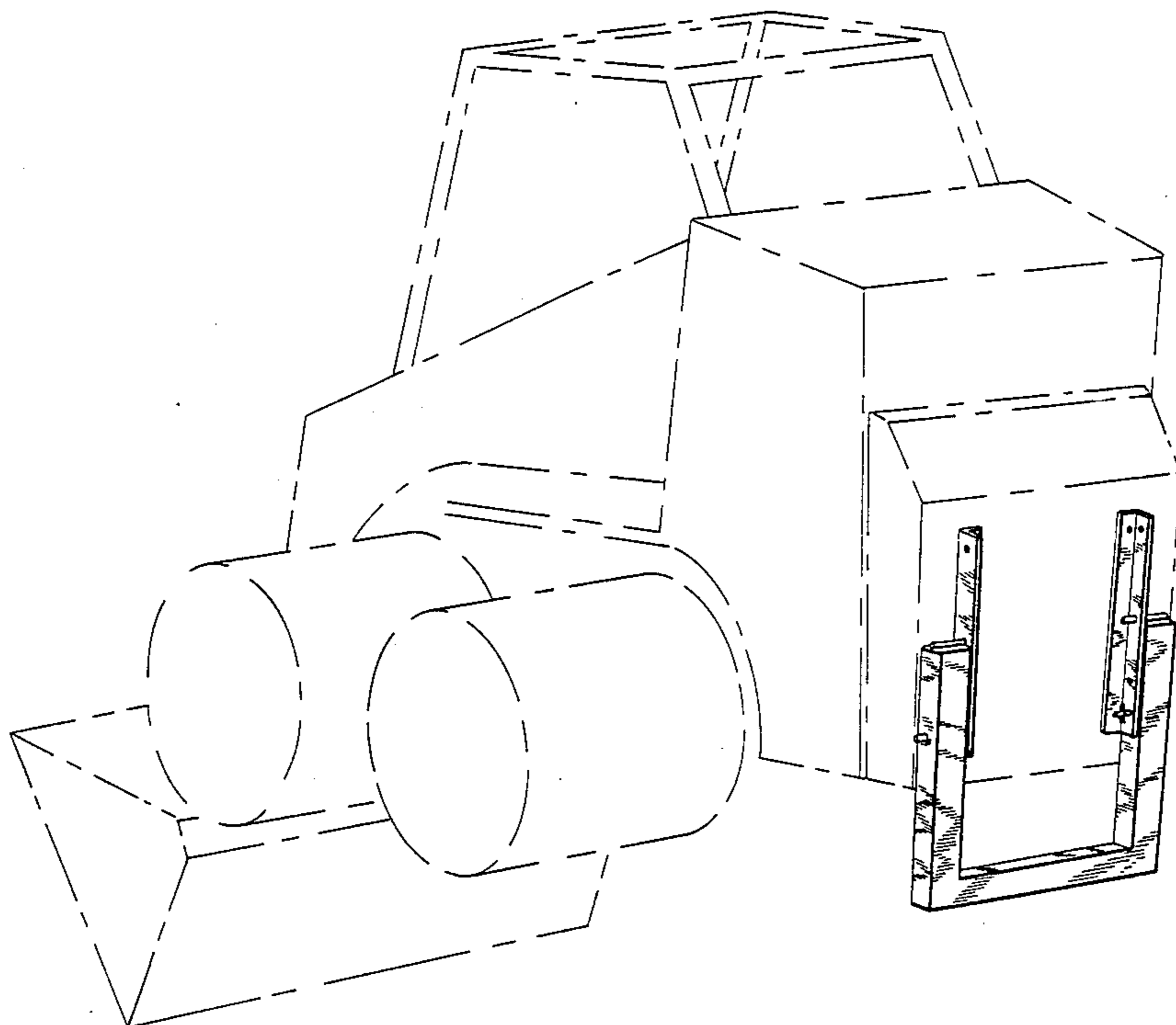

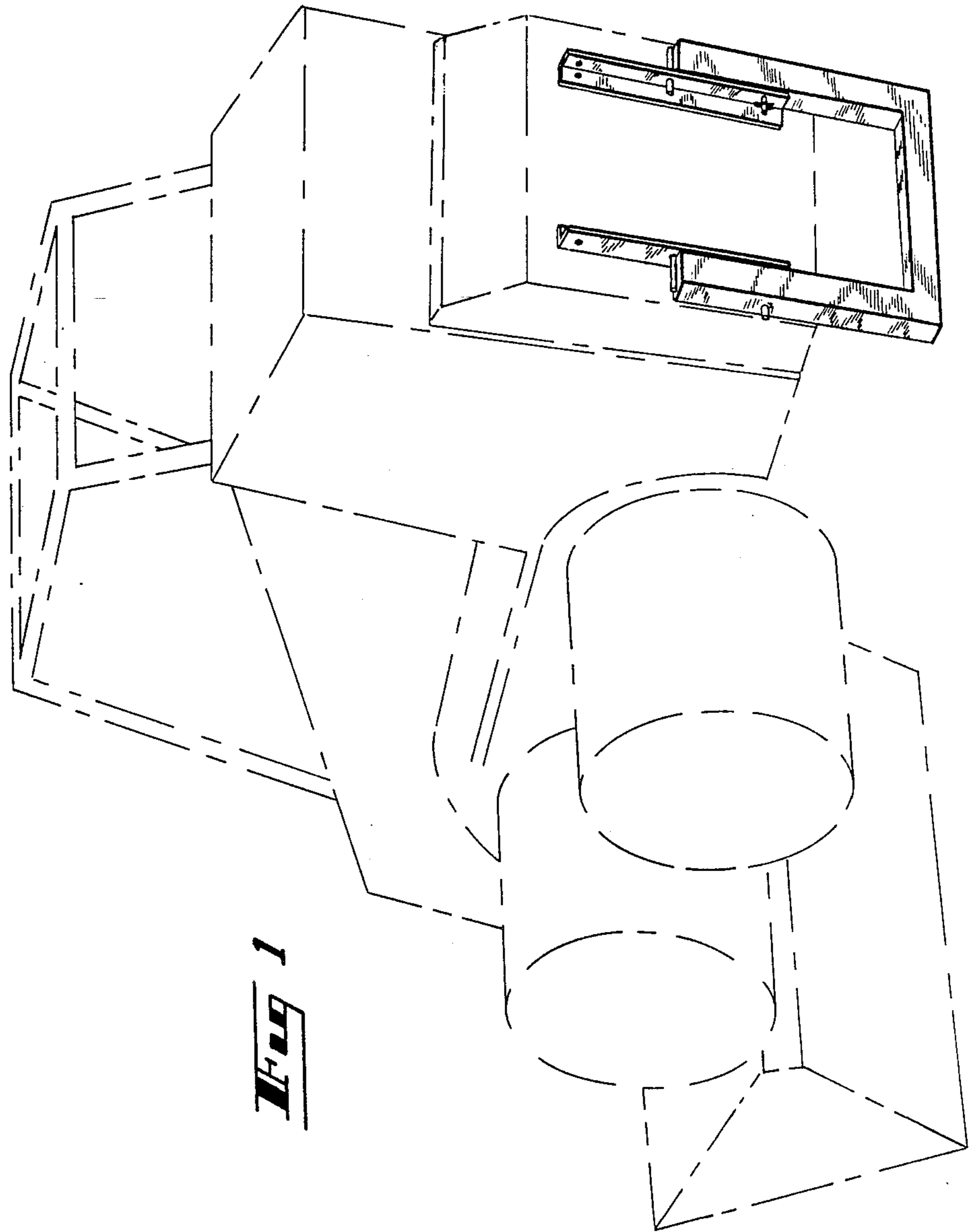

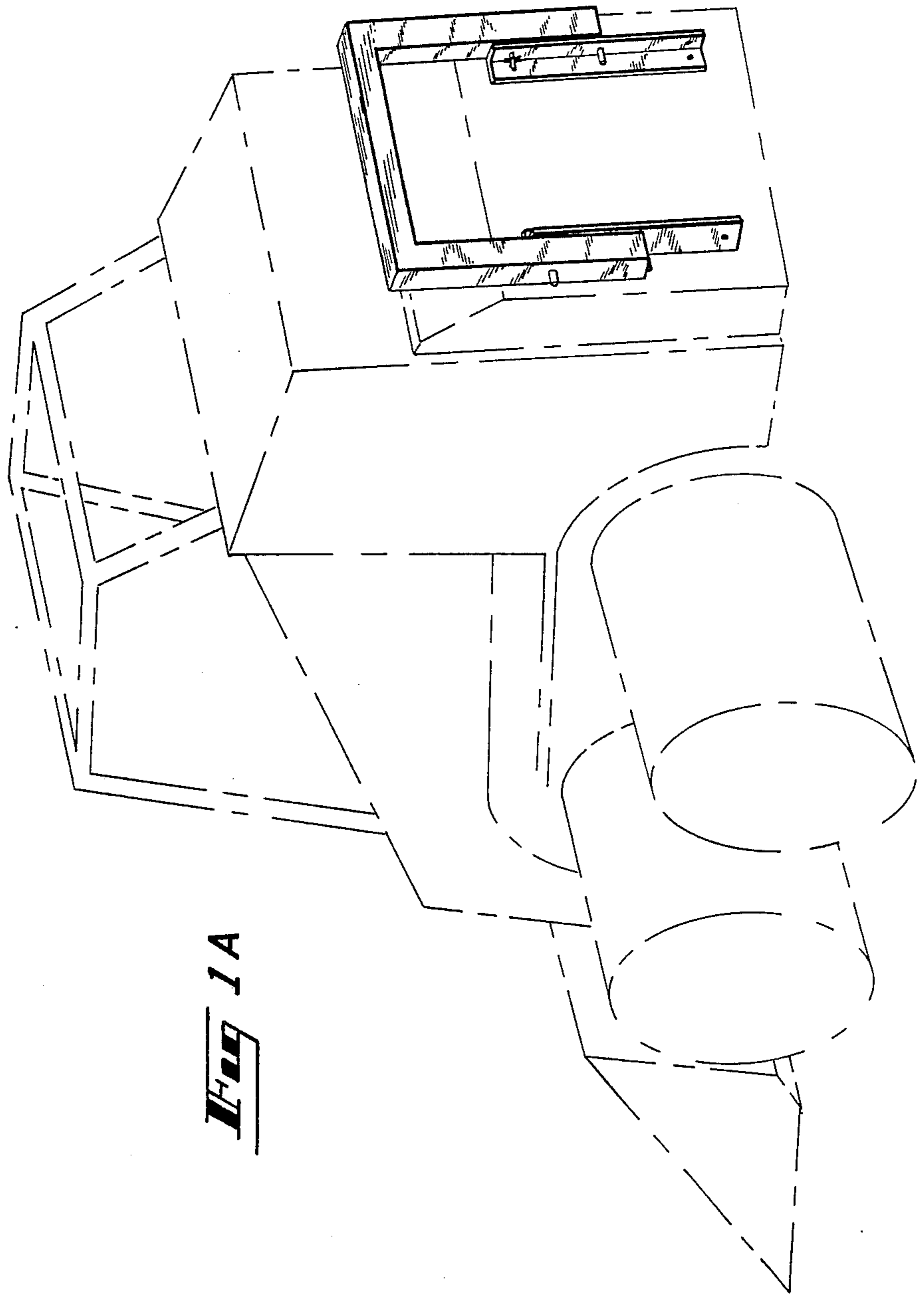

FIG 1A

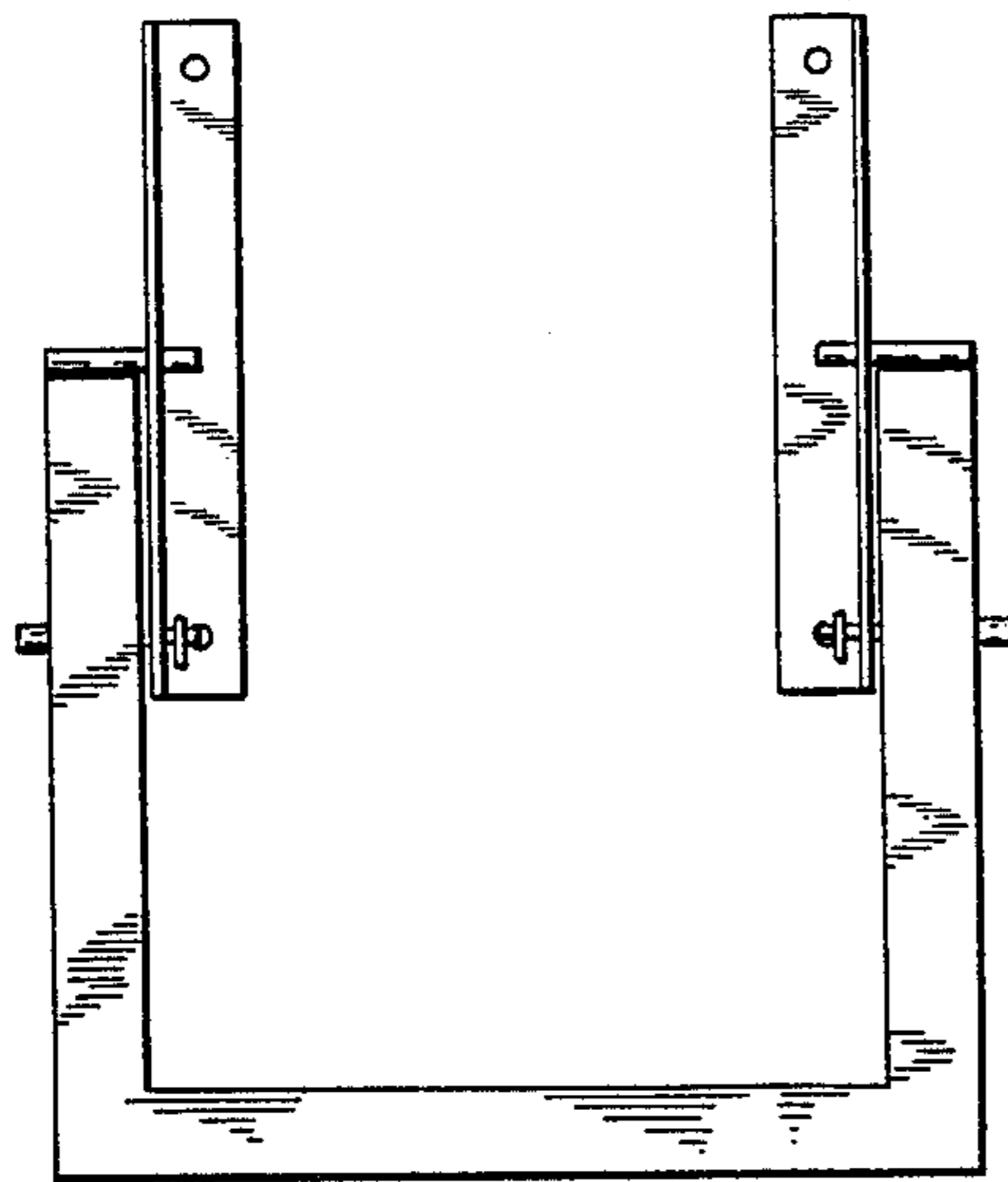

FIG 2

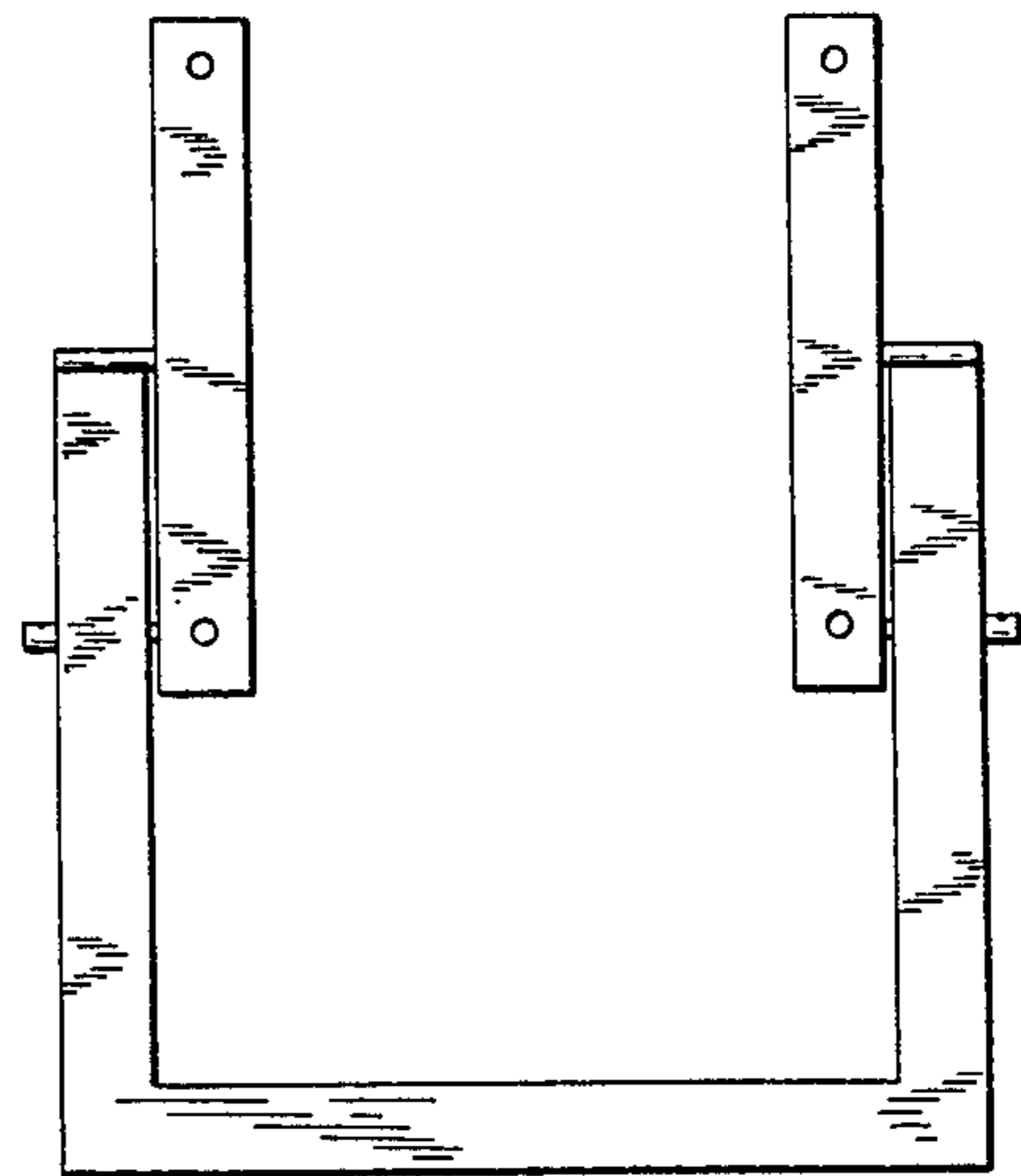

FIG 3



FIG 4

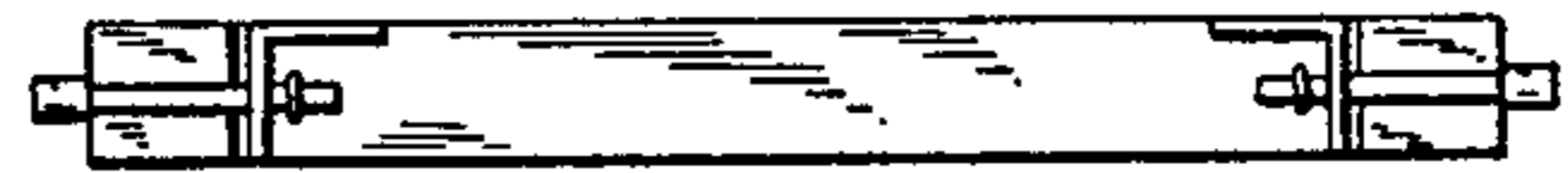

FIG 5

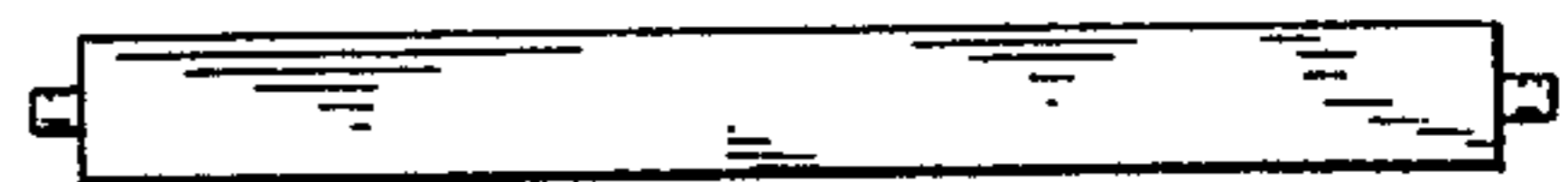

FIG 6