

# United States Patent [19]

Powers et al.

[11] Patent Number: **Des. 300,537**

[45] Date of Patent: **\*\* Apr. 4, 1989**

[54] **GUITAR HEAD**

D. 275,963 10/1984 Smith ..... D17/14 X

[75] Inventors: **Michael V. Powers; Hartley D. Peavey**, both of Meridian, Miss.

[73] Assignee: **Peavey Electronics Corporation**, Meridian, Miss.

[\*\*] Term: **14 Years**

[21] Appl. No.: **818,357**

[22] Filed: **Jan. 13, 1986**

[52] U.S. Cl. .... **D17/20**

[58] Field of Search ..... **D17/14, 15, 18, 19, D17/20, 21, 99; 84/304, 305, 306, 293**

[56] **References Cited**

### U.S. PATENT DOCUMENTS

D. 249,583 9/1978 Worthing et al. .... D17/20  
D. 255,461 6/1980 Todd, III ..... D17/20  
D. 269,524 6/1983 Burge ..... D17/14

### OTHER PUBLICATIONS

Purchaser's Guide to the Music Industries, ©1986, p. 297-bottom.

*Primary Examiner*—Bernard Ansher  
*Assistant Examiner*—Theodore M. Shooman  
*Attorney, Agent, or Firm*—Huff & Associates

[57] **CLAIM**

The ornamental design for a guitar head, as shown and described.

### DESCRIPTION

FIG. 1 is a front elevational view of a guitar head showing our new design;  
FIG. 2 is a left side elevational view thereof;  
FIG. 3 is a top plan view thereof, rotated 180 degrees from FIG. 1;  
FIG. 4 is a right side elevational view thereof; and  
FIG. 5 is a rear elevational view thereof.

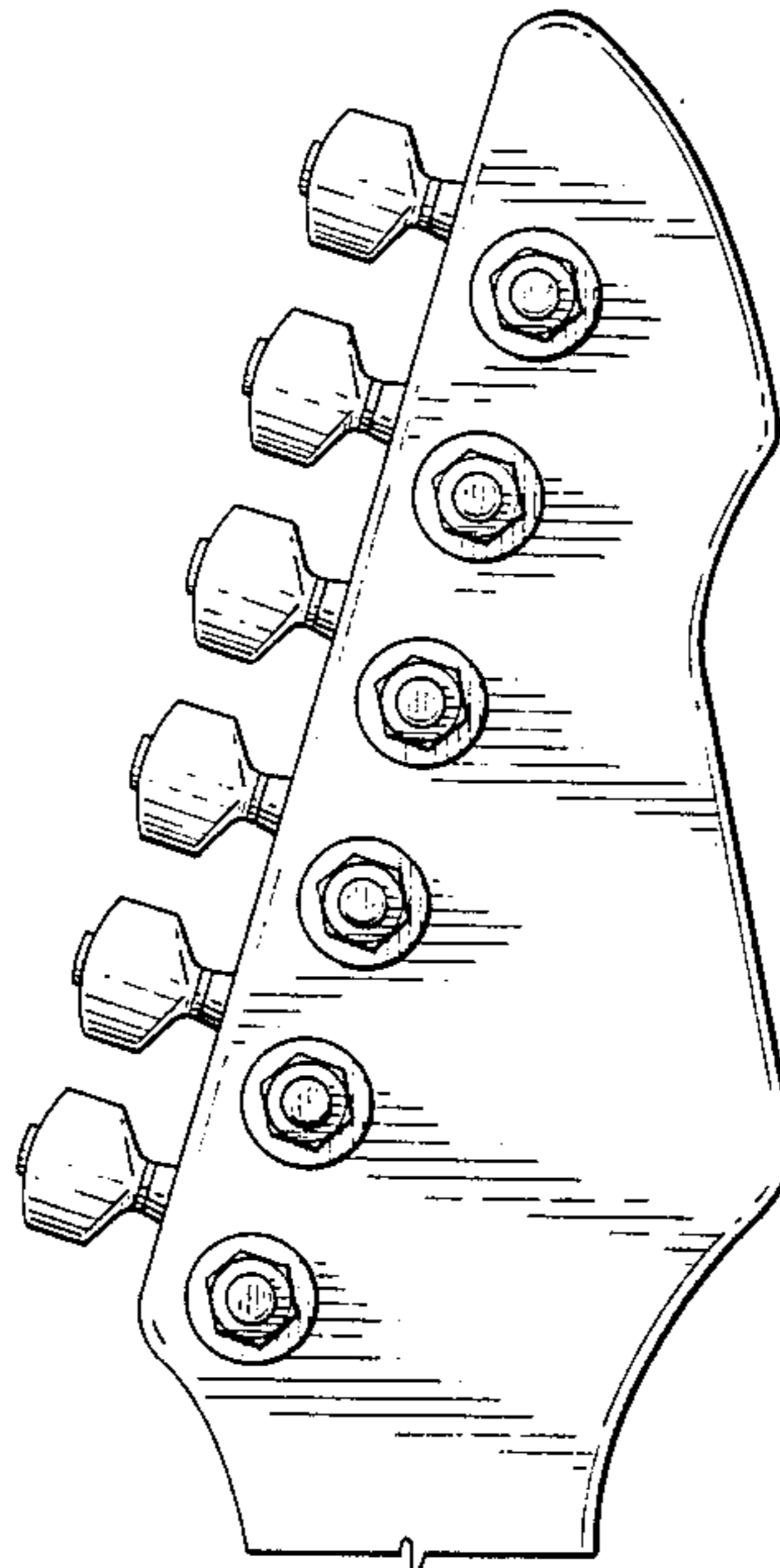

FIG. 1

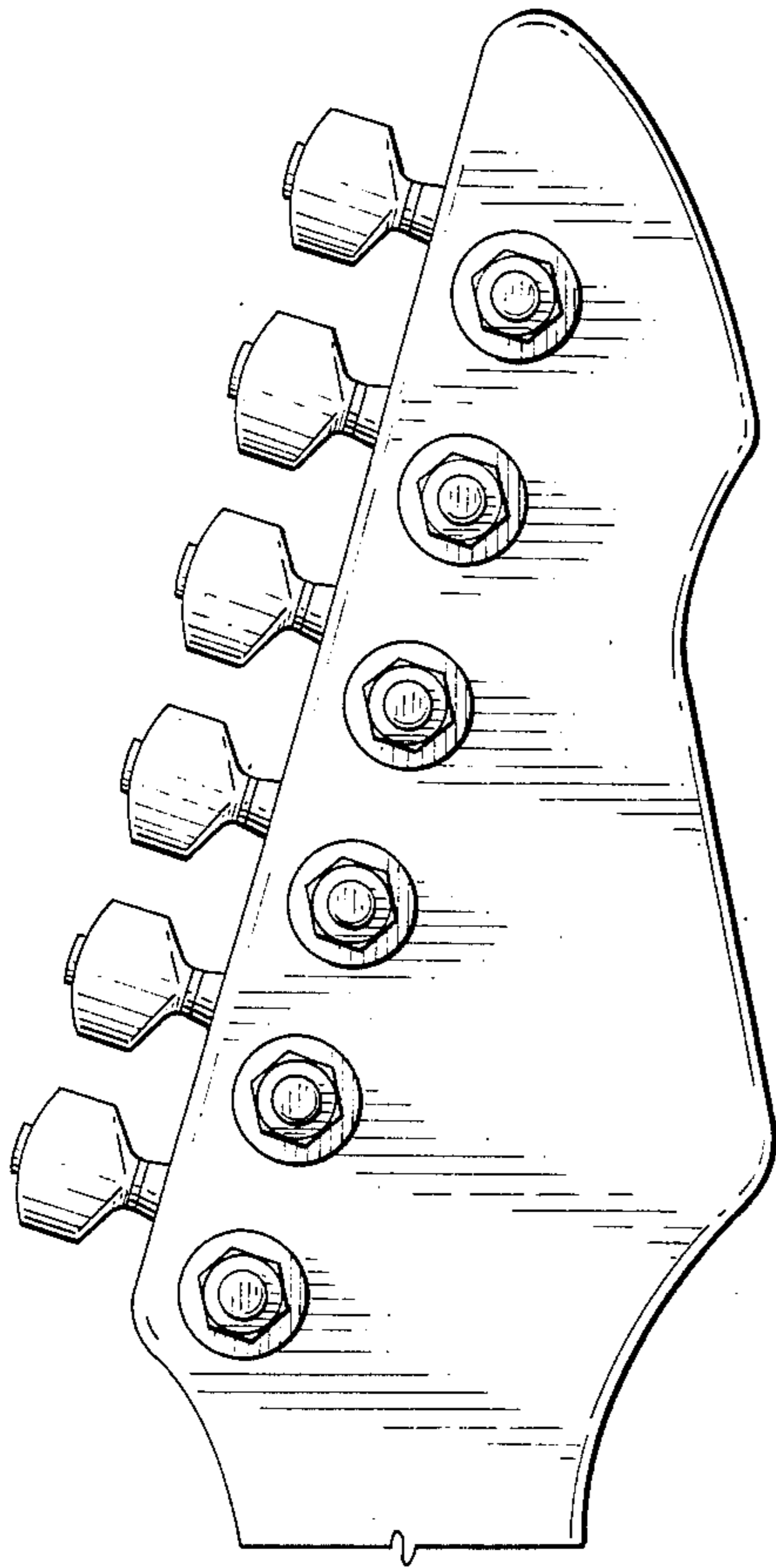

FIG. 2

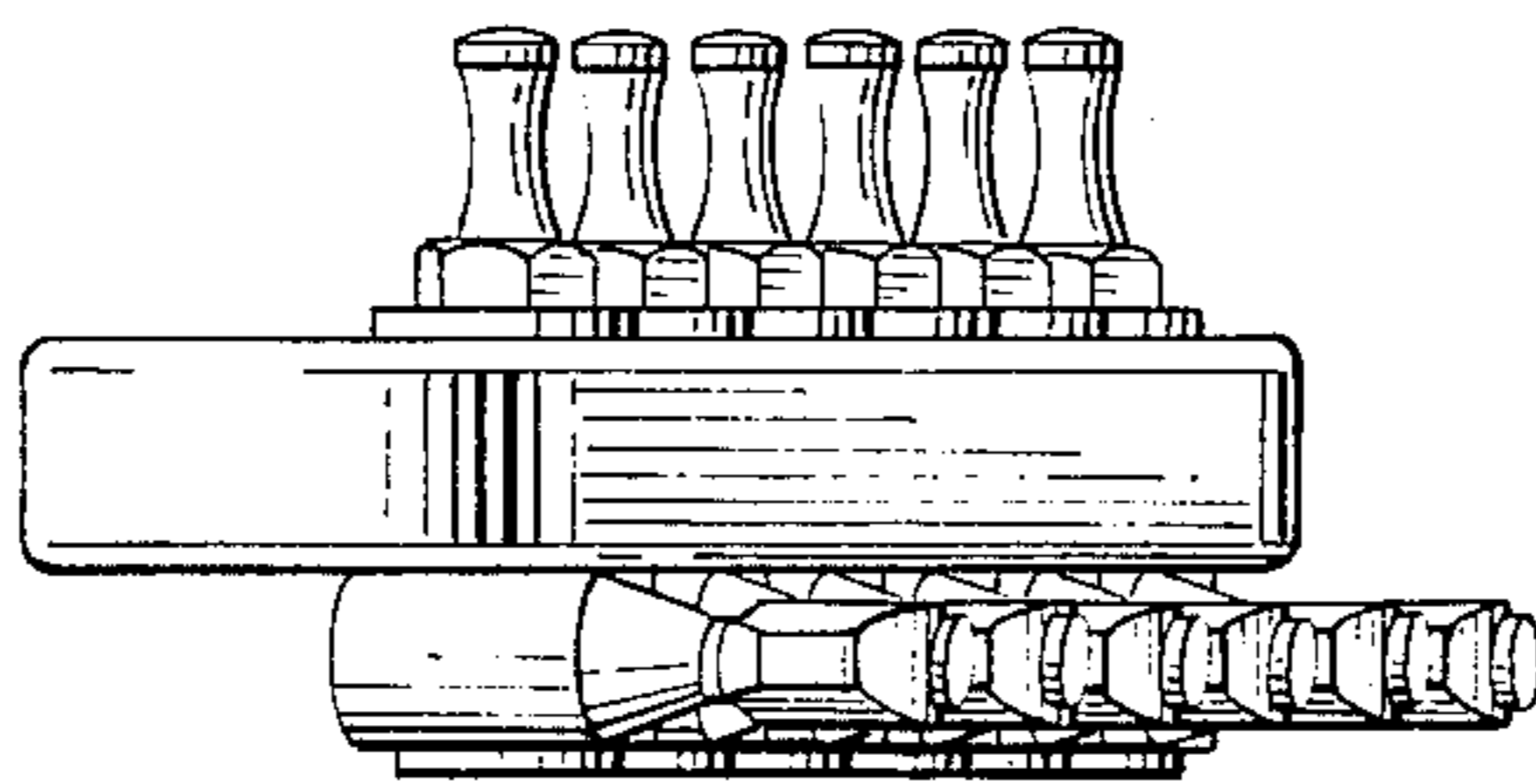
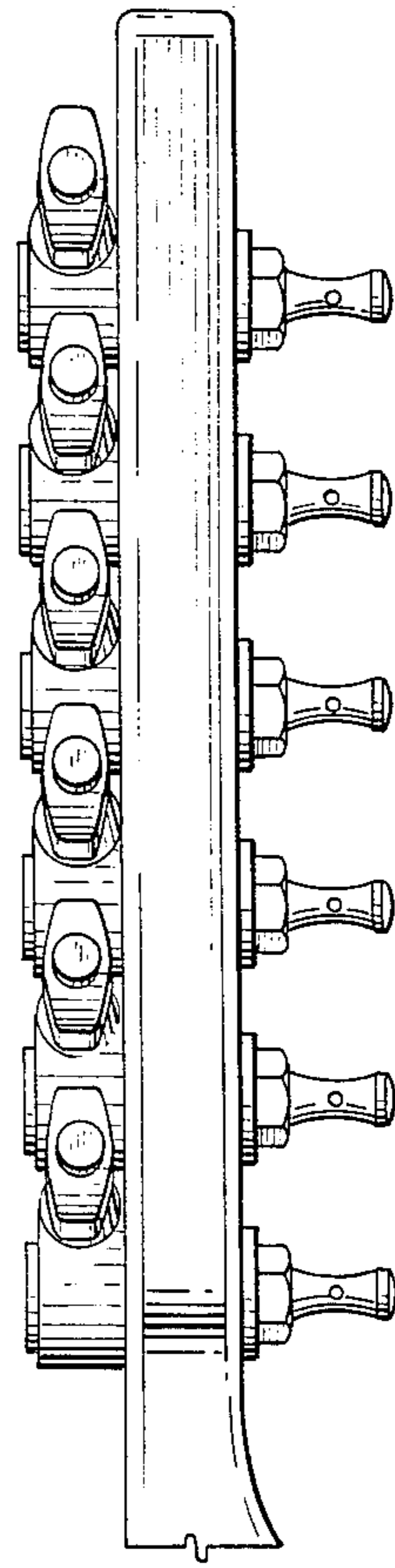

FIG. 3

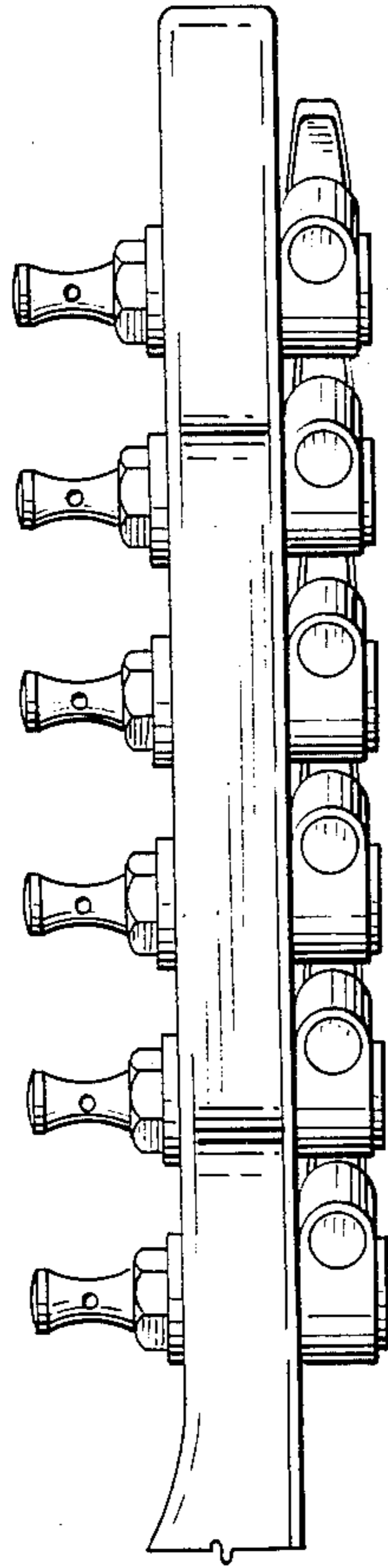

FIG. 4

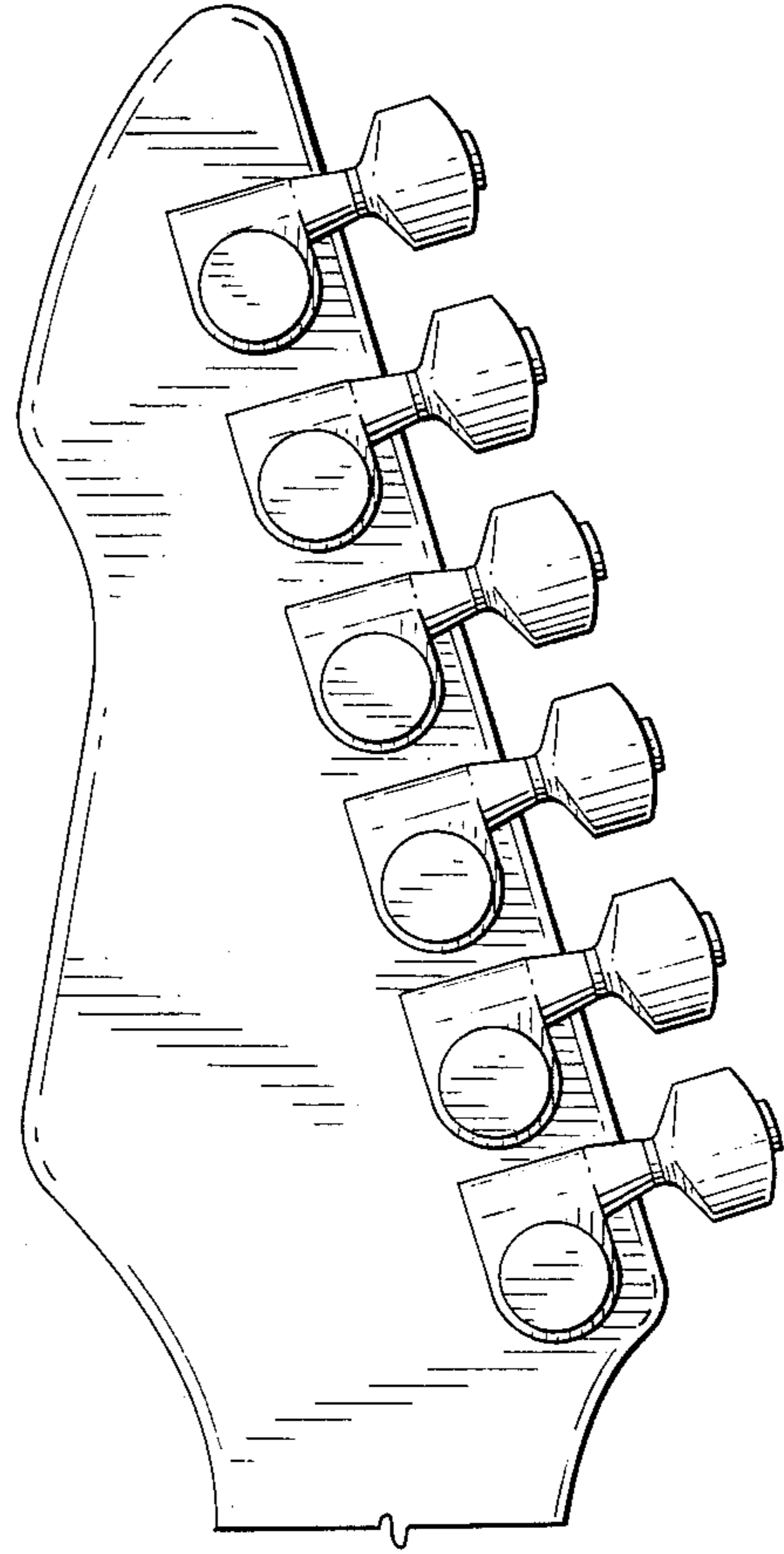

FIG. 5