

United States Patent [19]

Ito et al.

[11] Patent Number: **Des. 300,523**

[45] Date of Patent: **** Apr. 4, 1989**

[54] **MOTORCYCLE**

[75] Inventors: **Mamoru Ito; Fujio Nakamura**, both of Saitama, Japan

[73] Assignee: **Honda Giken Kogyo Kabushiki Kaisha**, Tokyo, Japan

[**] Term: **14 Years**

[21] Appl. No.: **927,413**

[22] Filed: **Nov. 4, 1986**

[30] **Foreign Application Priority Data**

May 19, 1986 [JP] Japan 61-18794
[52] U.S. Cl. **D12/110**
[58] Field of Search D12/110; 180/219, 220, 180/225, 229

[56] **References Cited**

U.S. PATENT DOCUMENTS

D. 286,520 11/1986 Kuwahata et al. D12/110
D. 289,988 5/1987 Ito D12/110

Primary Examiner—James M. Gandy
Attorney, Agent, or Firm—Lyon & Lyon

[57] **CLAIM**

The ornamental design for a motorcycle, as shown.

DESCRIPTION

FIG. 1 is a front elevation view of a motorcycle showing our new design;
FIG. 2 is a rear elevation view thereof;
FIG. 3 is an elevation view of the left side thereof;
FIG. 4 is an elevation view of the right side thereof;
FIG. 5 is a top plan view thereof; and
FIG. 6 is a perspective view thereof.

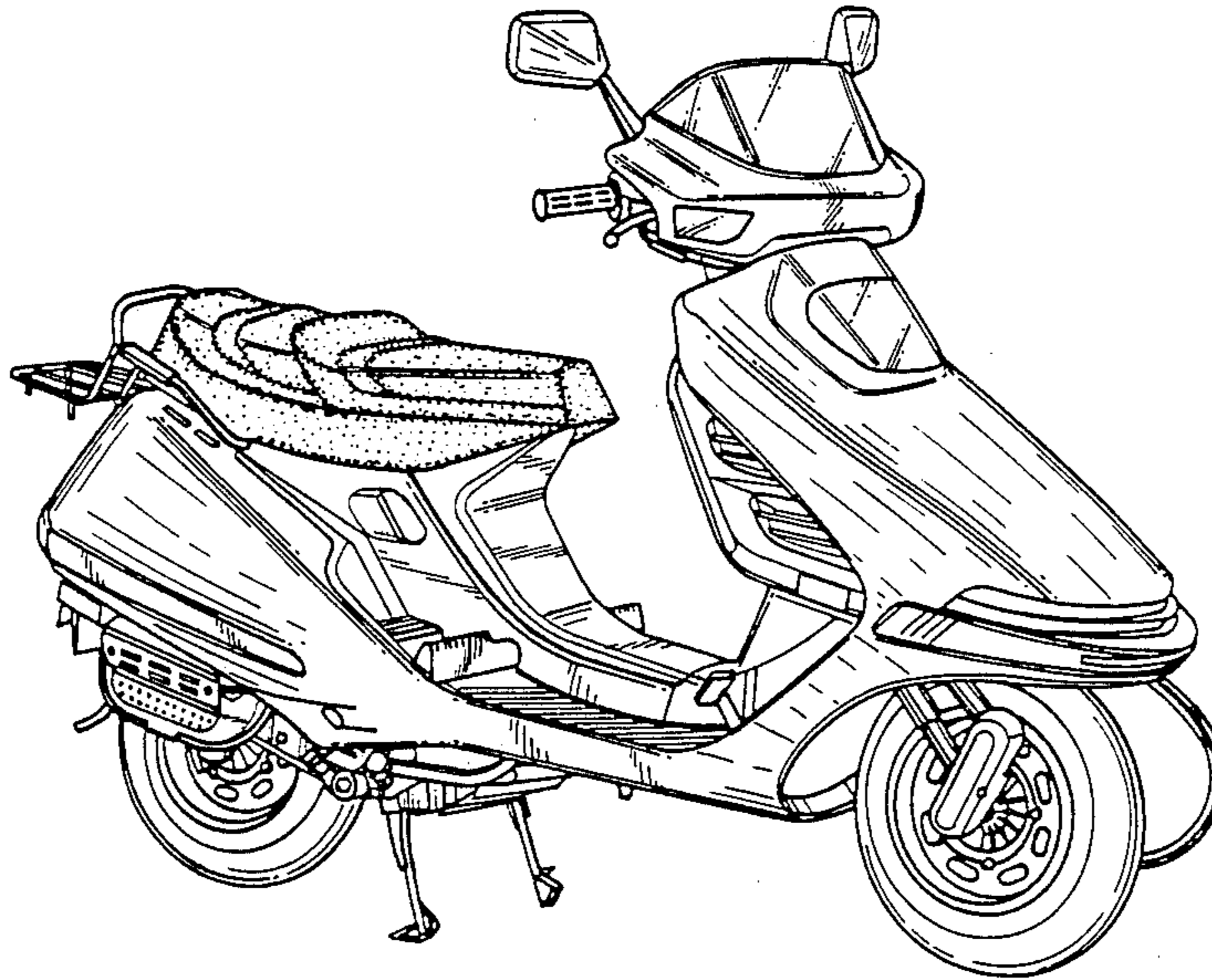

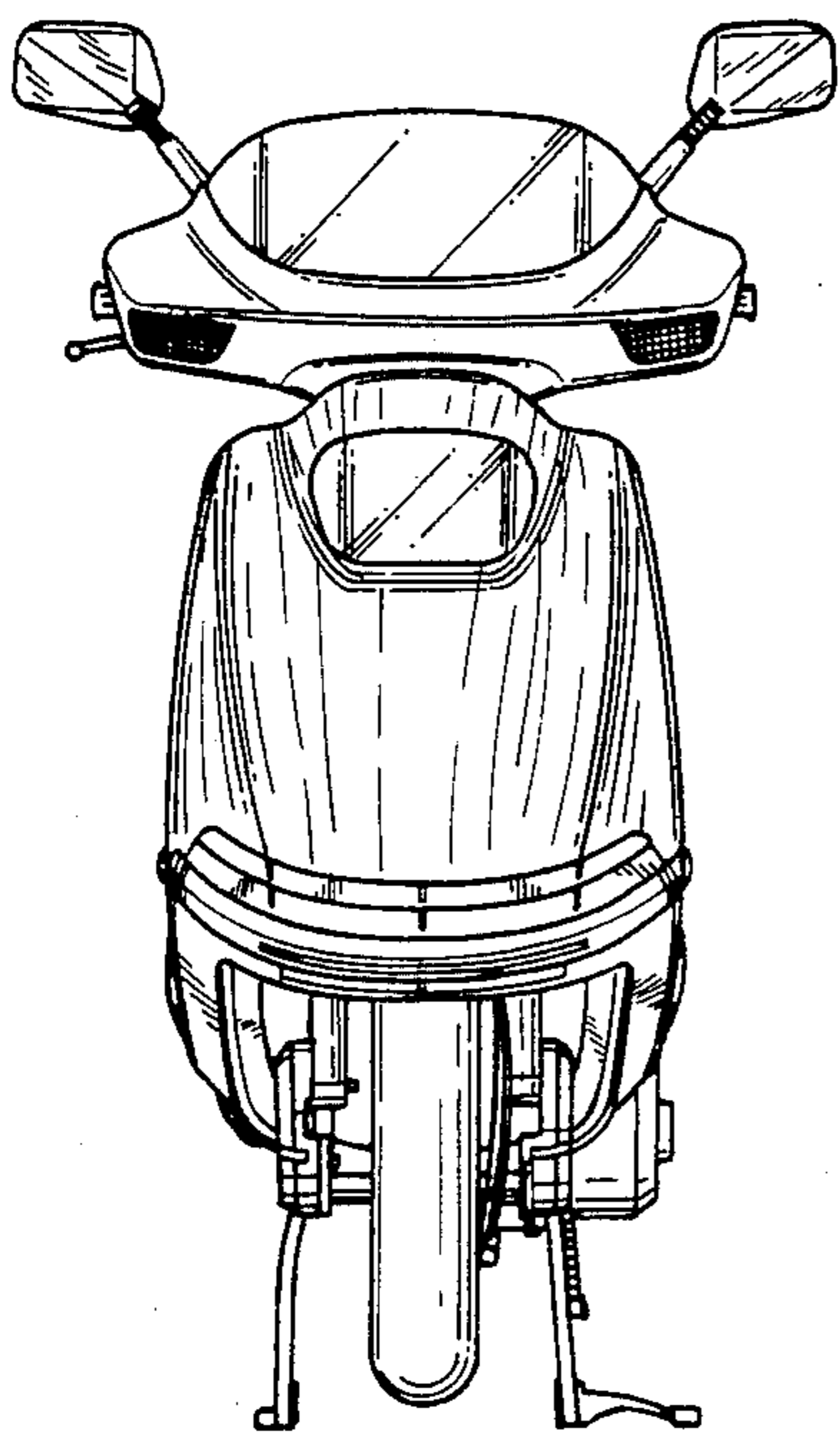

FIG. 1.

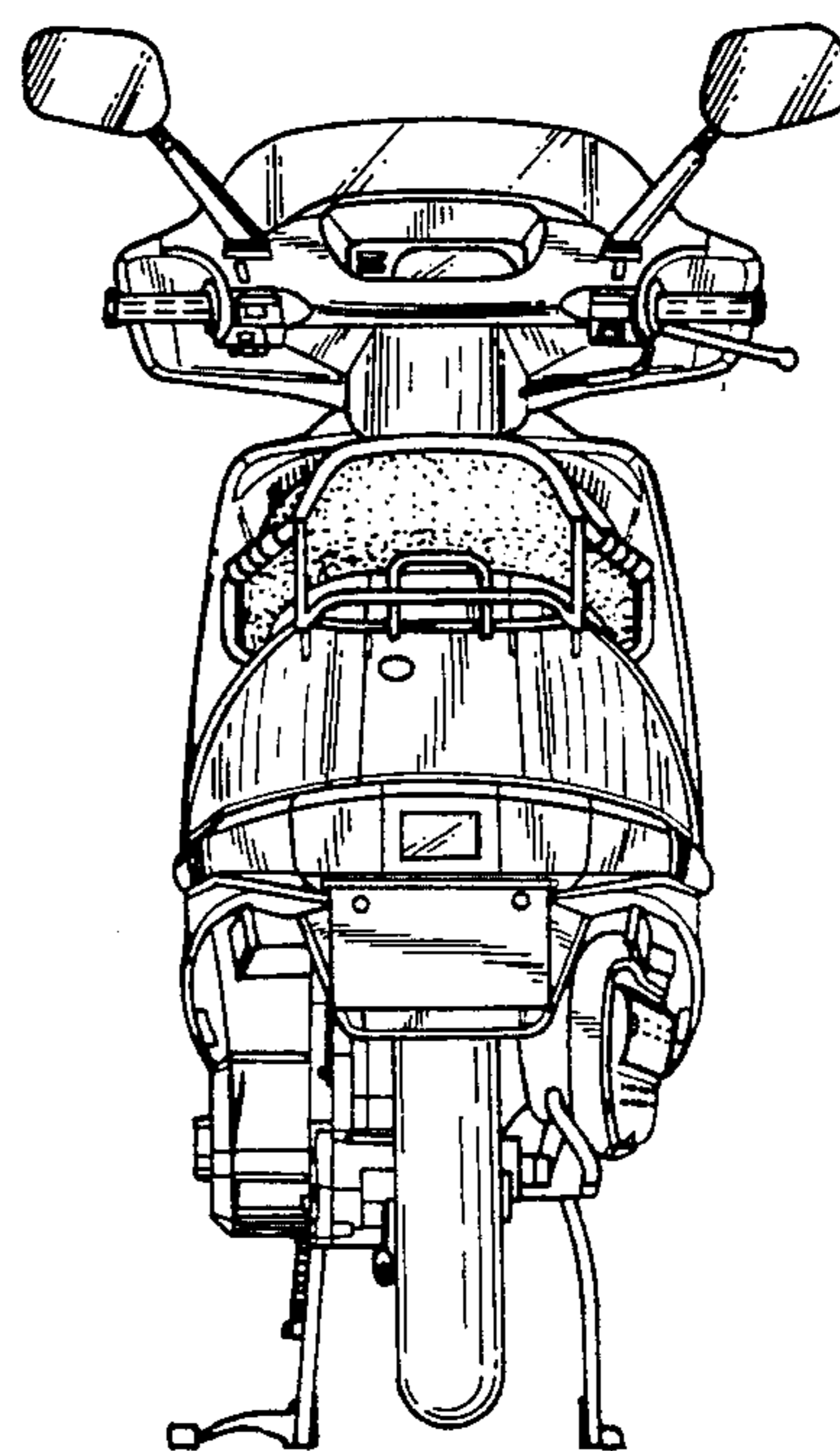

FIG. 2.

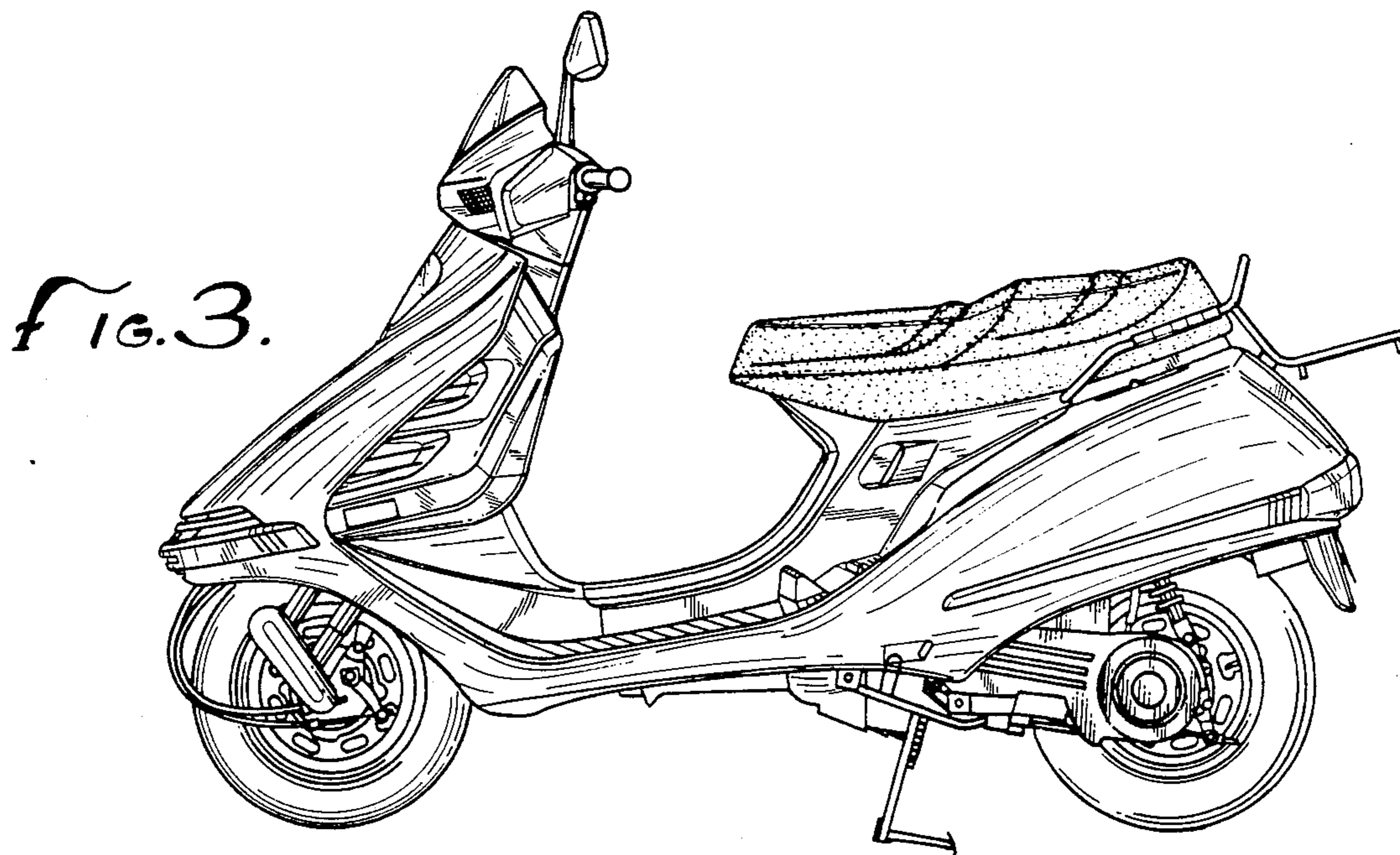

FIG. 3.

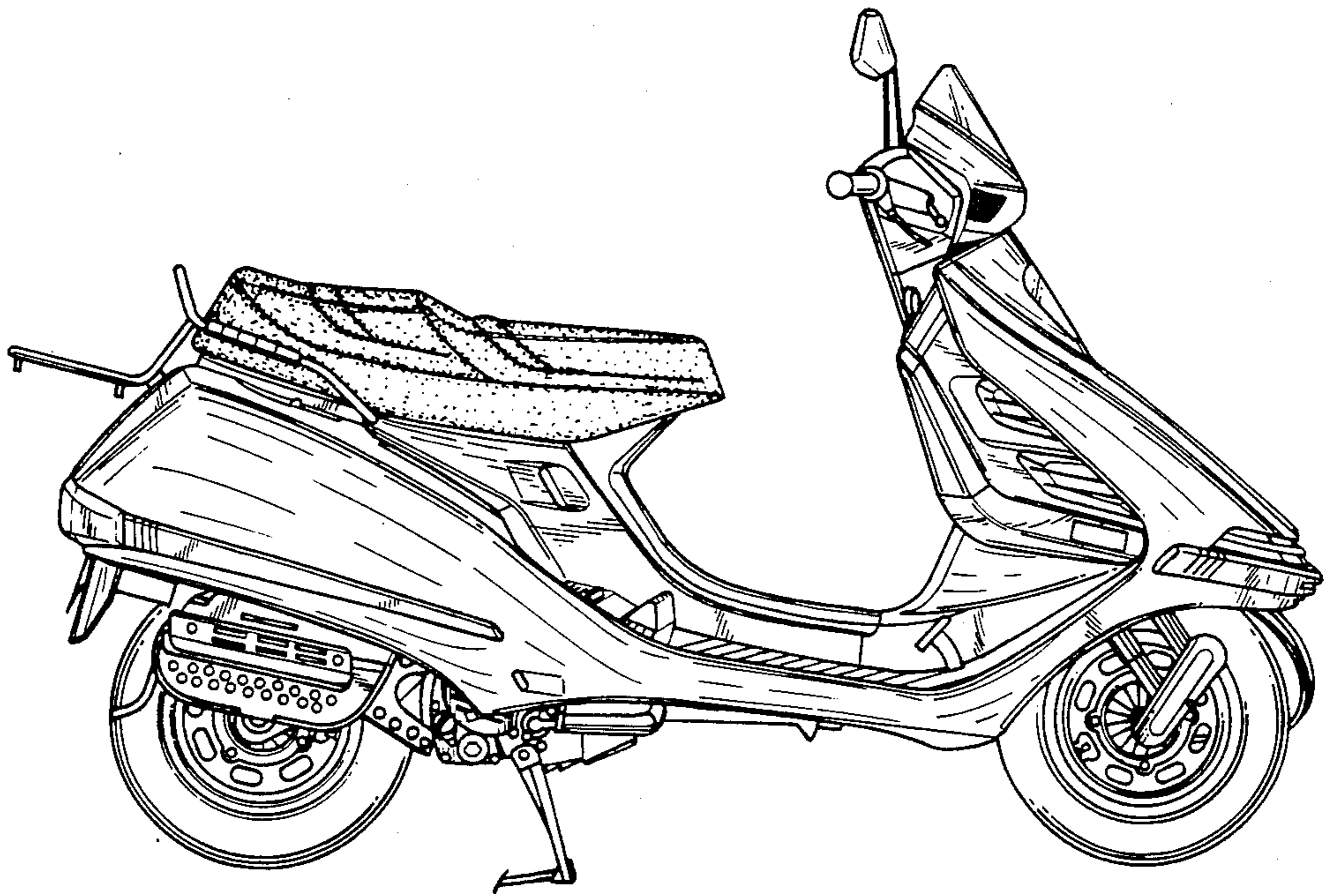

FIG. 4.

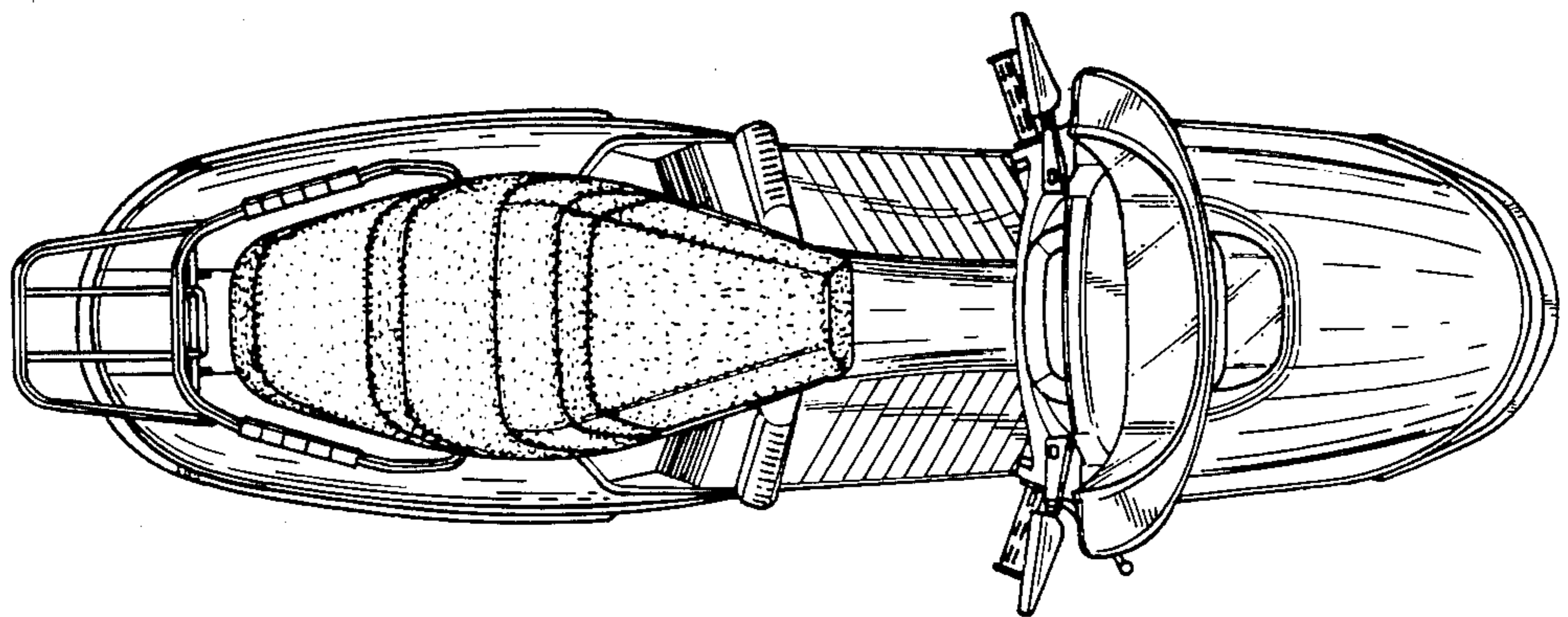

FIG. 5.

FIG. 6.

