

[54] FRONT FENDER FOR AN AUTOMOBILE

[75] Inventor: Takumi Ichikawa, Toyota, Japan

[73] Assignee: Toyota Jidosha Kabushiki Kaisha, Aichi, Japan

[\*\*] Term: 14 Years

[21] Appl. No.: 867,376

[22] Filed: May 27, 1986

[52] U.S. Cl. .... D12/184

[58] Field of Search ..... D12/184; 280/152 R

D. 294,818 3/1988 Kawatsu et al. .... D12/184

OTHER PUBLICATIONS

Road & Track, 1/85, p. 107, Front Fender of B.M.W. automobile, top of page.

Primary Examiner—James M. Gandy  
Attorney, Agent, or Firm—Parkhurst, Oliff & Berridge

[57] CLAIM

The ornamental design for a front fender for an automobile, as shown and described.

DESCRIPTION

FIG. 1 is a front perspective view of a front fender for an automobile;

FIG. 2 is a left side elevation view of the front fender;

FIG. 3 is a right side elevation view of the front fender;

FIG. 4 is a top plan view of the front fender;

FIG. 5 is a bottom plan view of the front fender;

FIG. 6 is a rear elevation view of the front fender; and

FIG. 7 is a front elevation view of the front fender.

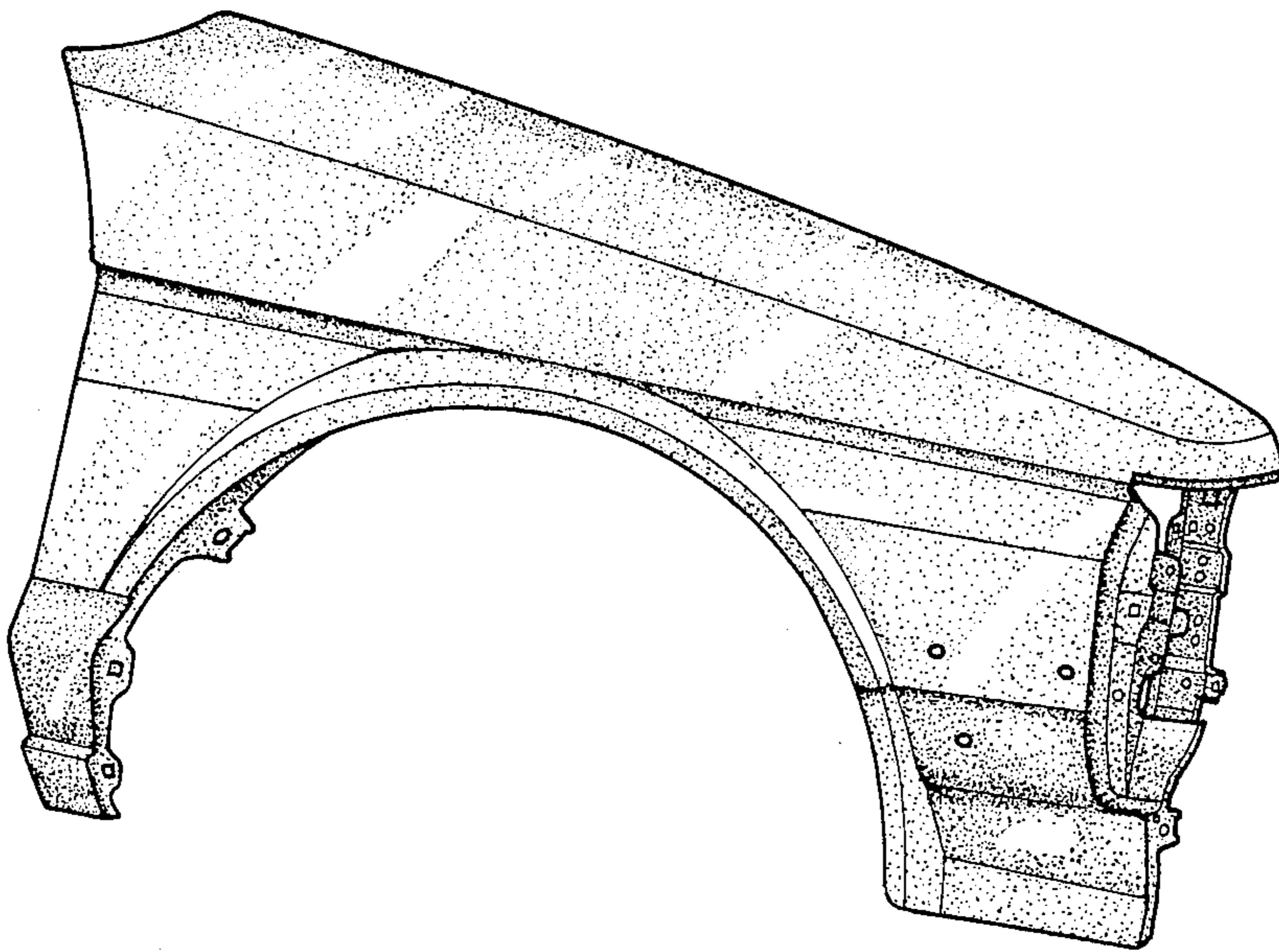

[56] References Cited  
U.S. PATENT DOCUMENTS

D. 240,914	8/1976	Wilsgaard	.....	D12/184
D. 246,708	12/1977	Tixier	.....	D12/184
D. 276,332	11/1984	Wilsgaard	.....	D12/184
D. 287,844	1/1987	Matsumoto et al.	.....	D12/184
D. 287,845	1/1987	Matsumoto et al.	.....	D12/184
D. 288,195	2/1987	Envall et al.	.....	D12/184

Fig. 1

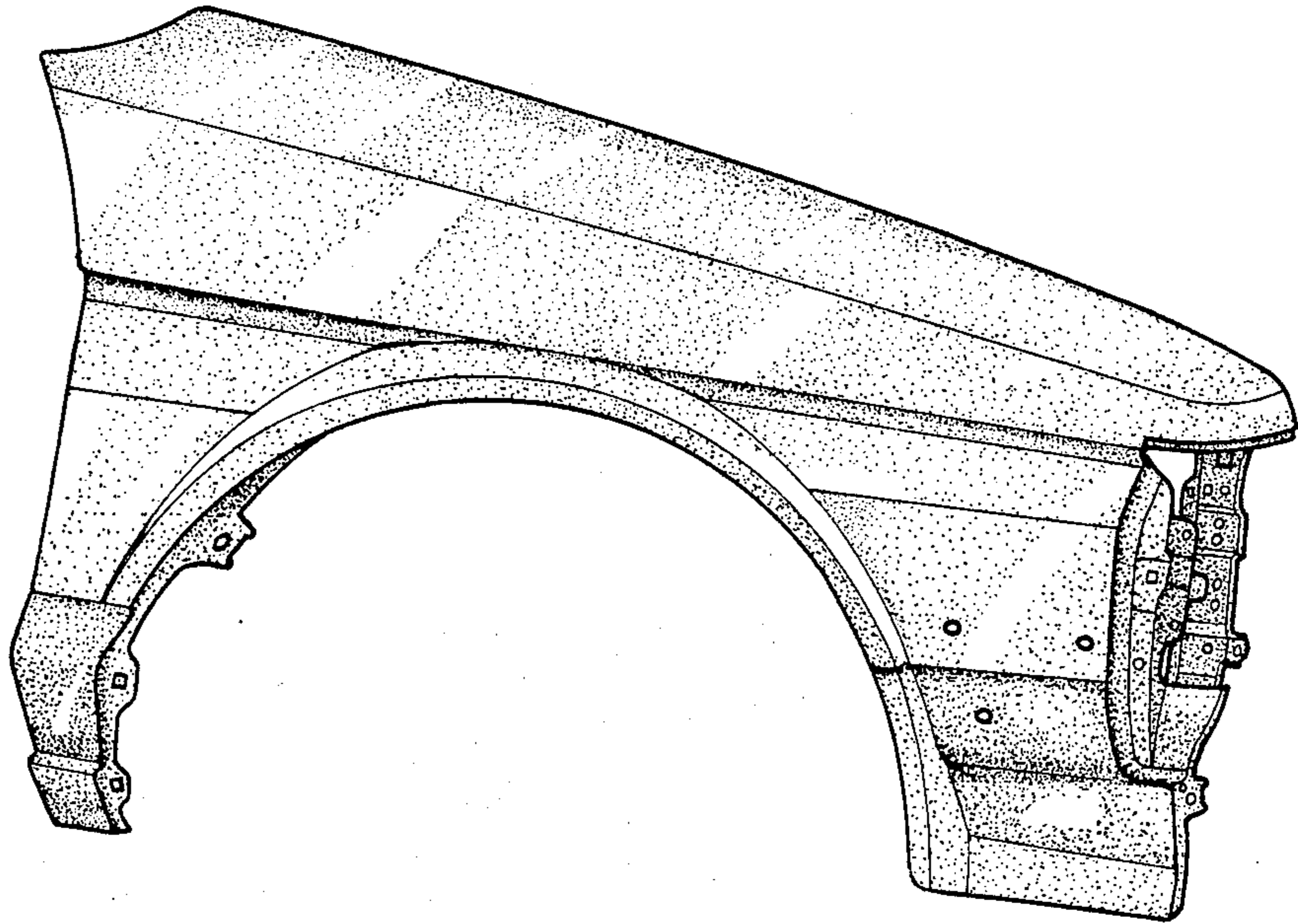

Fig. 2

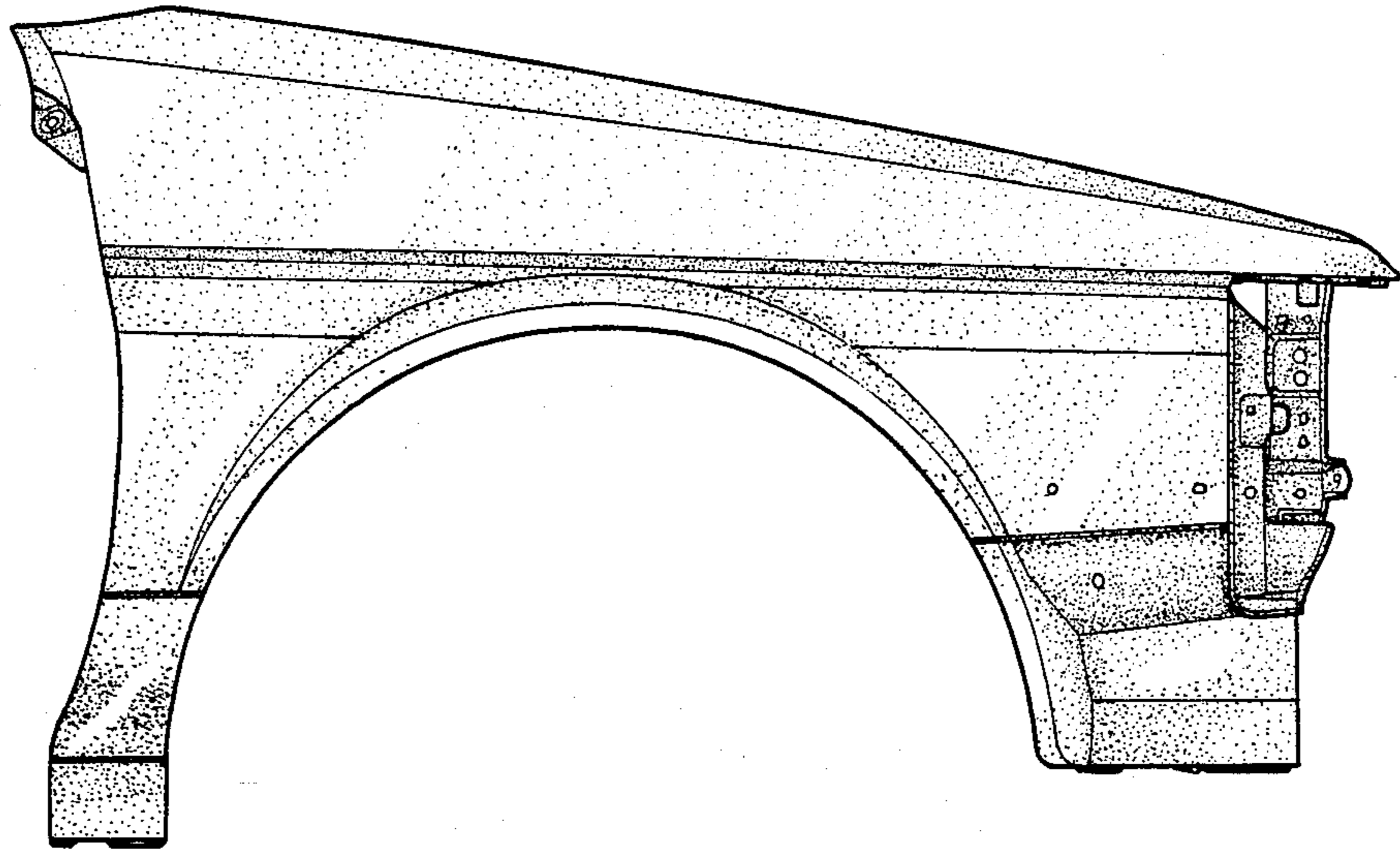

Fig. 3

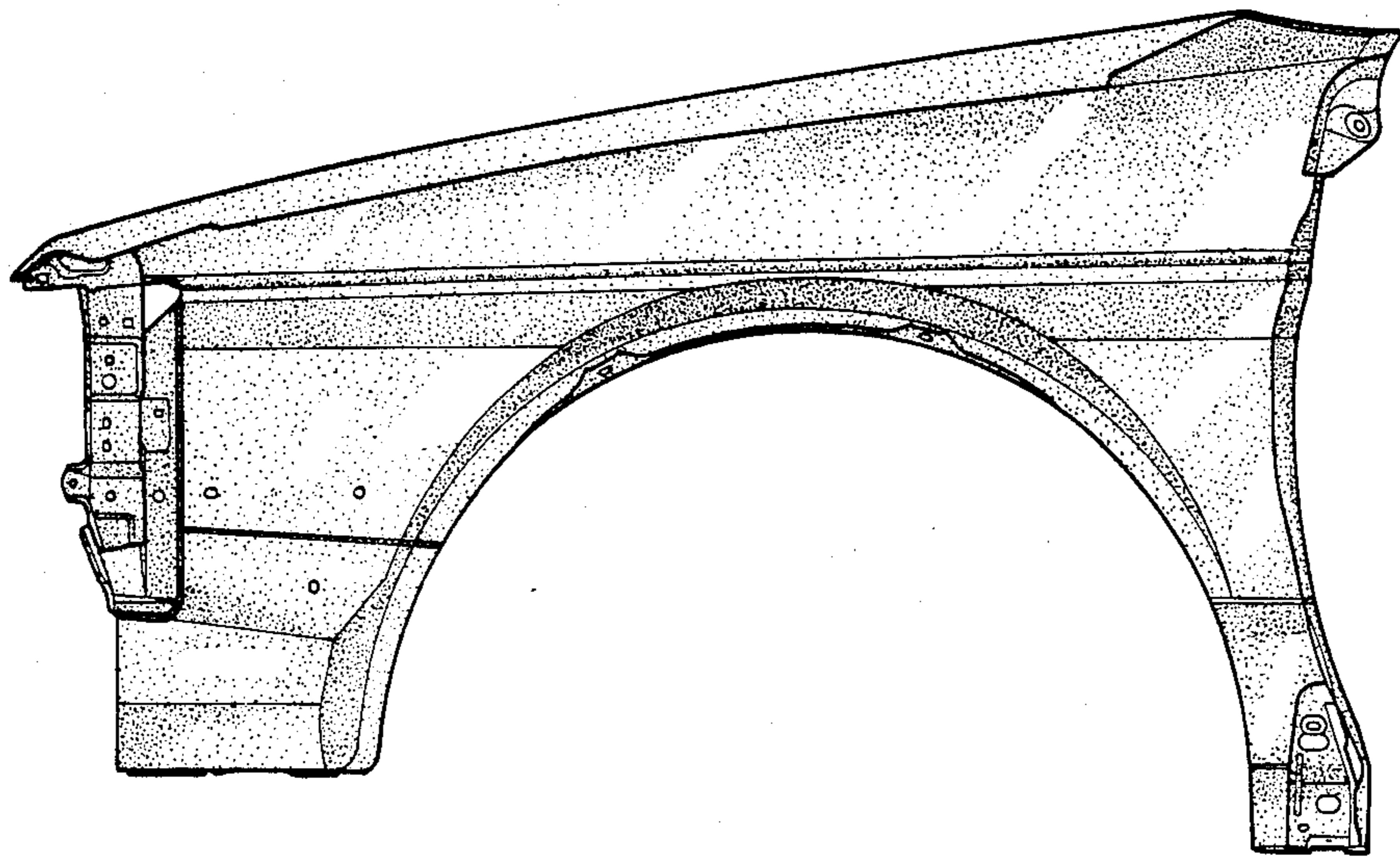

Fig. 4

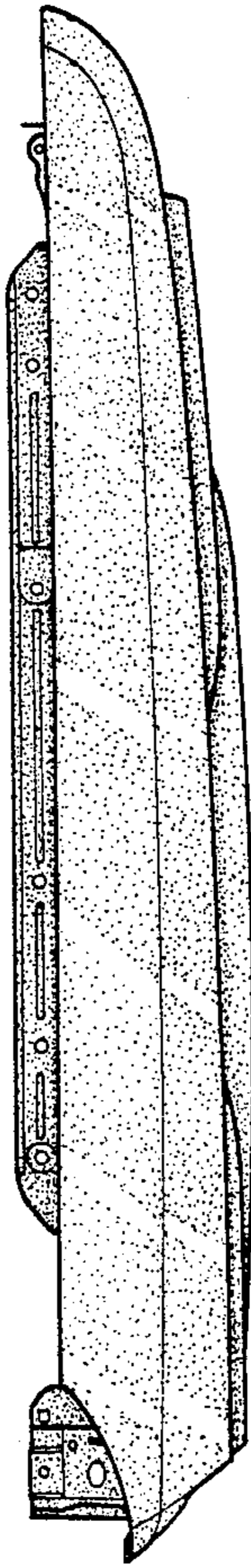

Fig. 5

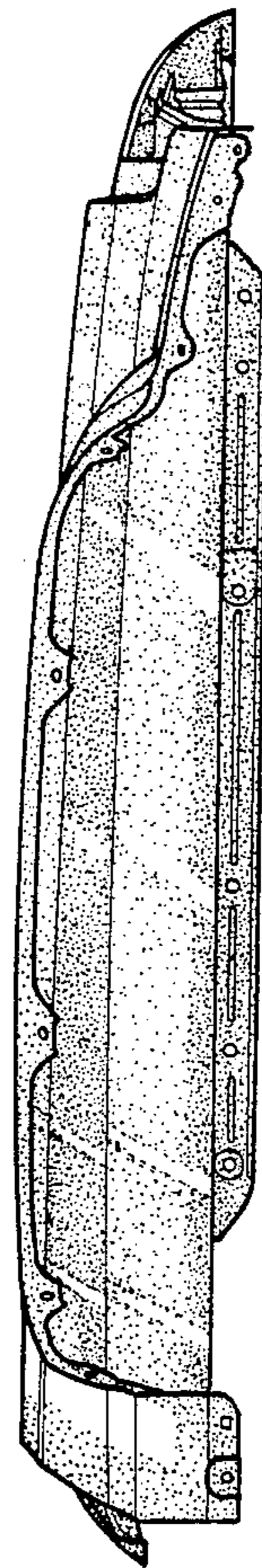

Fig. 7

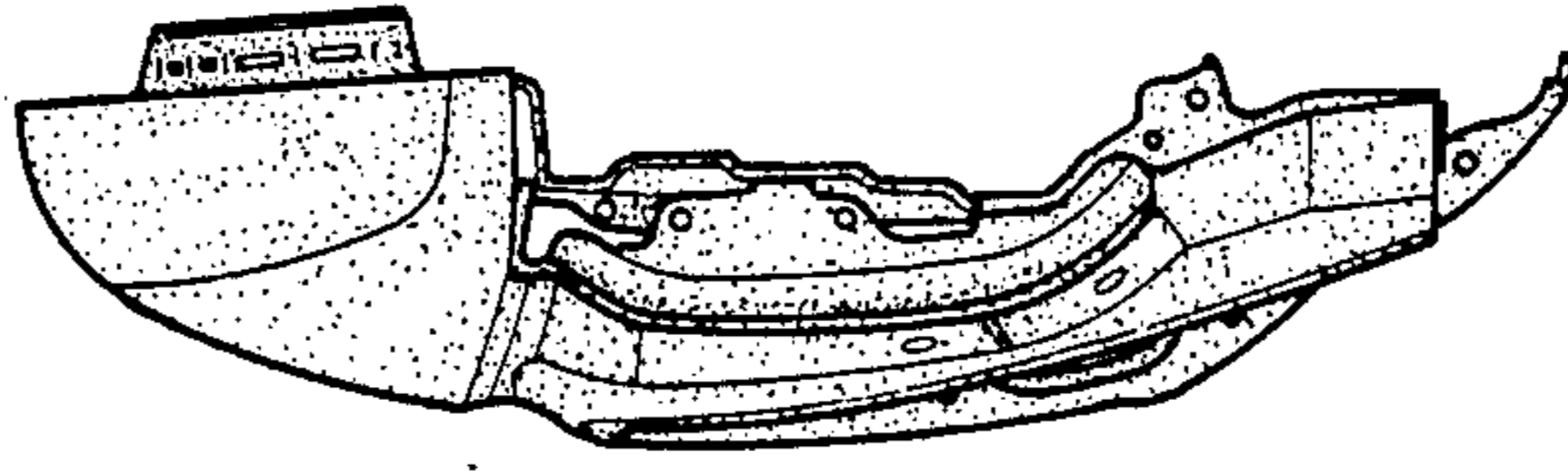

Fig. 6

