

[54] SHELL FOR A COMBINED DUMMY FUEL TANK AND SIDE COVER UNIT FOR A MOTORCYCLE

[75] Inventors: Toshiyuki Yamada, Saitama; Makoto Kitagawa, Tokyo; Toshio Kurihara, Saitama, all of Japan

[73] Assignee: Honda Giken Kogyo Kabushiki Kaisha, Tokyo, Japan

[\*\*] Term: 14 Years

[21] Appl. No.: 113,807

[22] Filed: Oct. 26, 1987

Related U.S. Application Data

[62] Division of Ser. No. 780,561, Sep. 26, 1985.

[30] Foreign Application Priority Data

Apr. 30, 1985 [JP] Japan ..... 60-17805  
[52] U.S. Cl. .... D12/114; D12/155  
[58] Field of Search ..... D12/114, 117, 155

[56] References Cited

U.S. PATENT DOCUMENTS

D. 286,519 11/1986 Komuro et al. .... D12/110

OTHER PUBLICATIONS

Cycle World, 6/84, p. 4, Dummy Fuel Tank & Side Cover of Honda Gold Wine Aspencade, center left side of page.

Cycle World, 12/84, p. 31, Dummy Fuel Tank & Side Cover of Honda Gold Wine Aspencade, center & top right side of page.

Primary Examiner—James M. Gandy  
Attorney, Agent, or Firm—Lyon & Lyon

[57] CLAIM

The ornamental design for a shell for a combined dummy fuel tank and side cover unit for a motorcycle, as shown and described.

DESCRIPTION

FIG. 1 is a top plan view of a shell for a combined dummy fuel tank and side cover unit for a motorcycle showing our new design;

FIG. 2 is a side elevation view illustrating the left side thereof and;

FIG. 3 is a side elevation view illustrating the right side thereof.

The broken line showing of a motorcycle is for illustrative purposes only and forms no part of the claimed design.

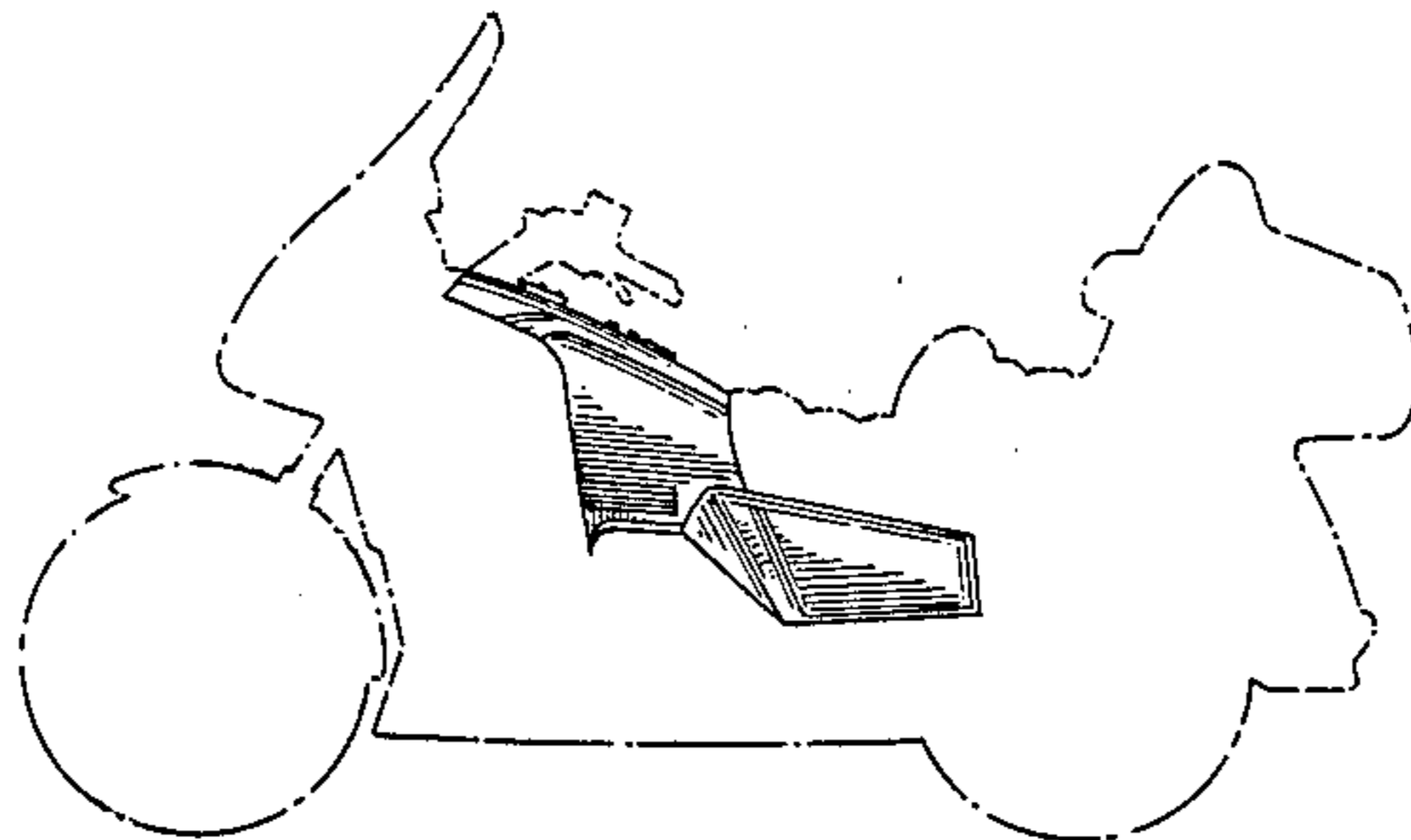
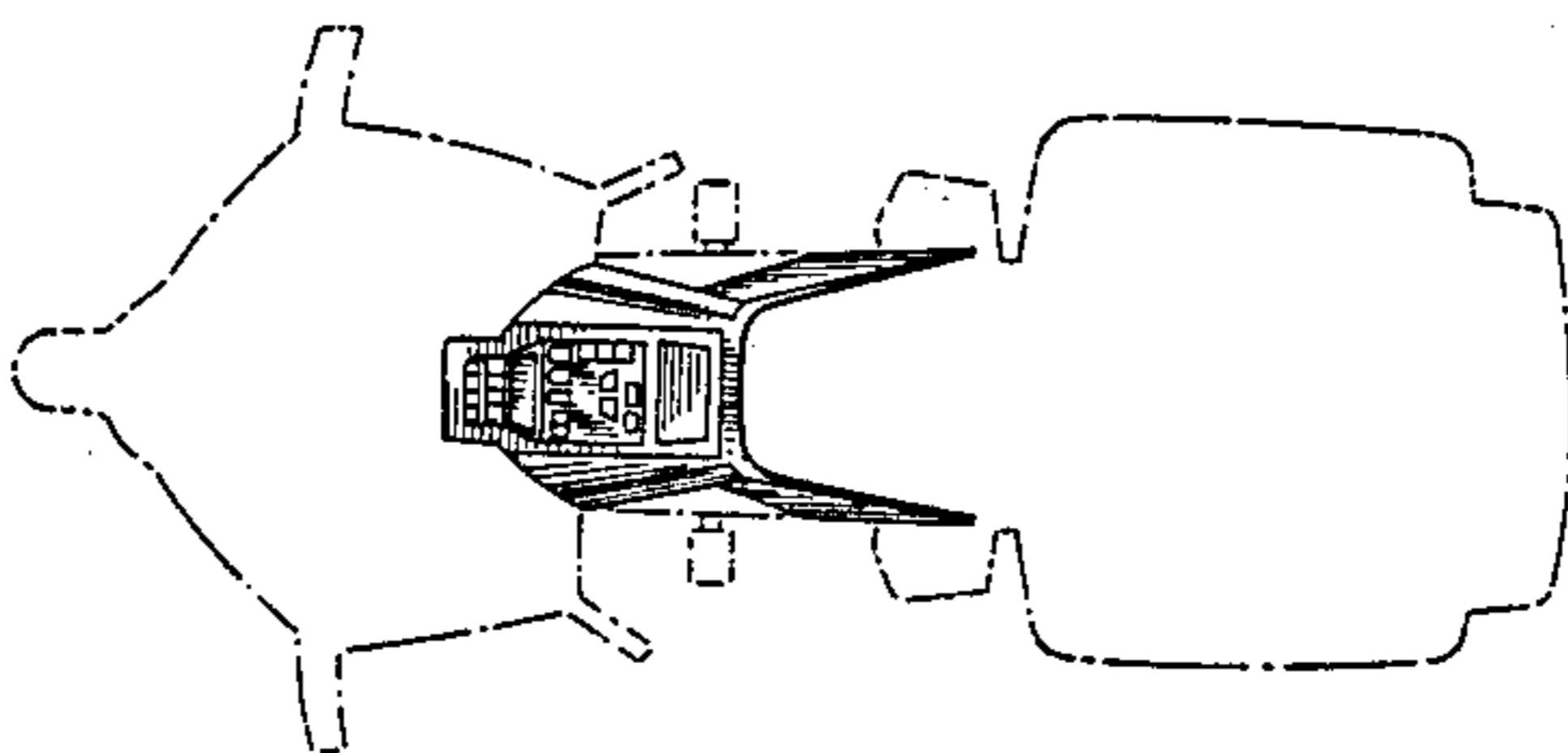

**FIG. 1**

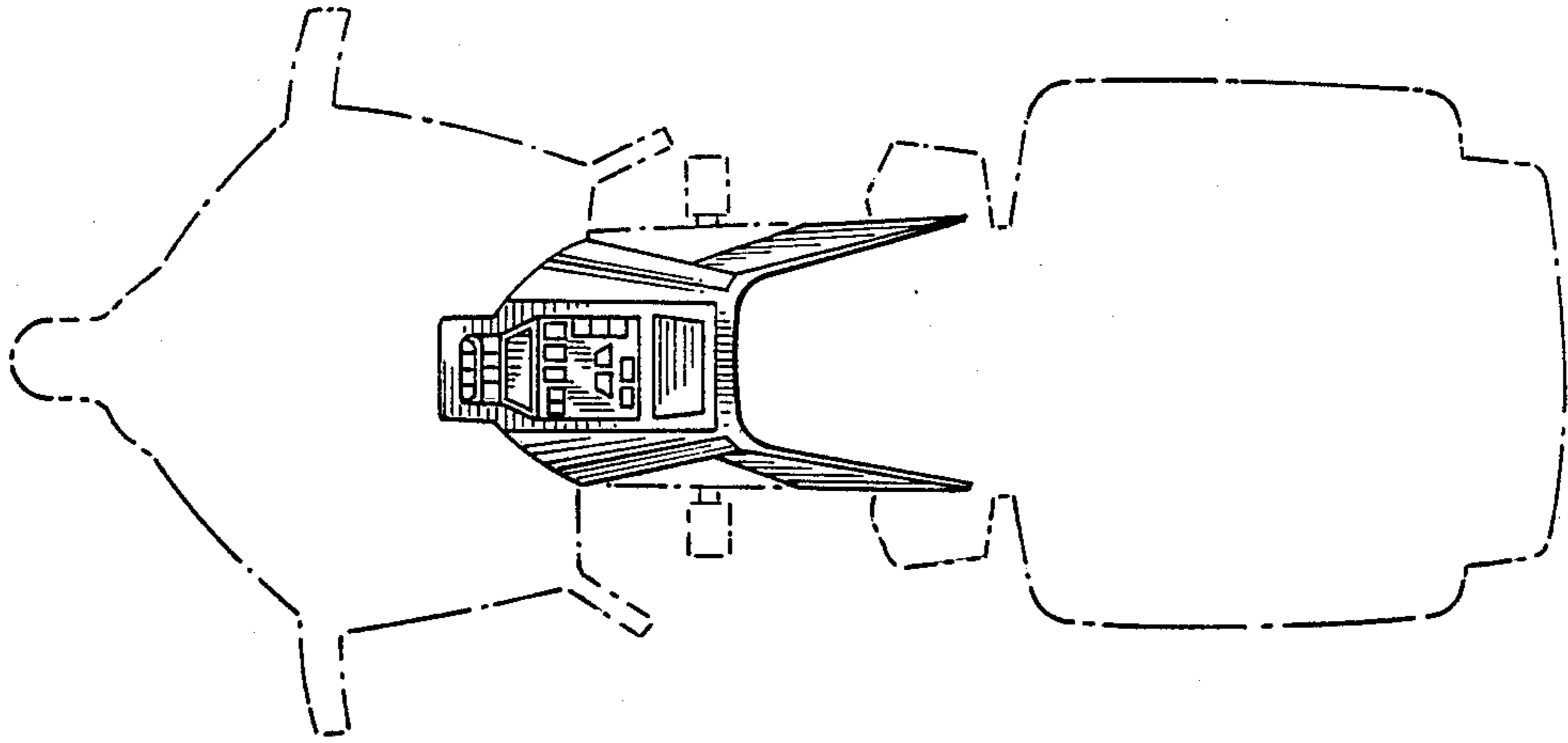

**FIG. 2**

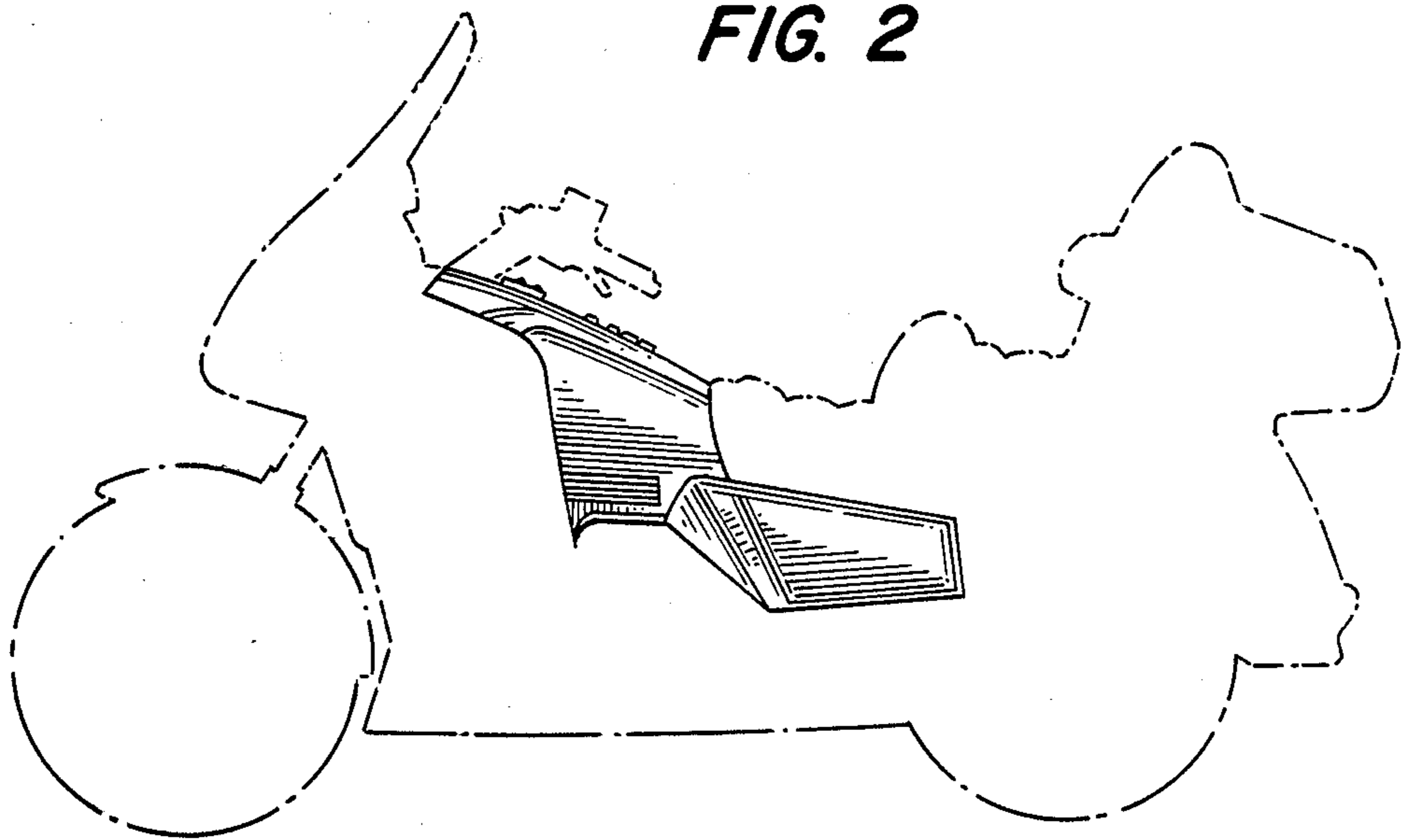

**FIG. 3**

