

[54] TRAILER SIMULATING THE PHYSICAL IMPACT OF A HEAD-ON VEHICULAR COLLISION

[76] Inventor: F. C. Britten, 17000 Hull St. Rd., Chesterfield, Va. 23832

[**] Term: 14 Years

[21] Appl. No.: 841,120

[22] Filed: Mar. 3, 1986

[52] U.S. Cl. D12/101

[58] Field of Search D12/101; 434/62, 67; 280/63

[56] References Cited

U.S. PATENT DOCUMENTS

1,240,629	9/1917	Torr	434/67
4,580,985	4/1986	Redenbaugh	434/62

Primary Examiner—James M. Gandy
Attorney, Agent, or Firm—Norman B. Rainer

[57] CLAIM

The ornamental design for a trailer simulating the physical impact of a head-on vehicular collision, as shown and described.

DESCRIPTION

FIG. 1 is a side elevation view of a trailer simulating the physical impact of a head-on vehicular collision showing my new design, it being understood that the opposite side is a mirror image thereof;
FIG. 2 is a rear elevation view thereof, taken from the right-side of FIG. 1;
FIG. 3 is a front elevation view thereof, taken from the left side of FIG. 1; and
FIG. 4 is a top plan view thereof.

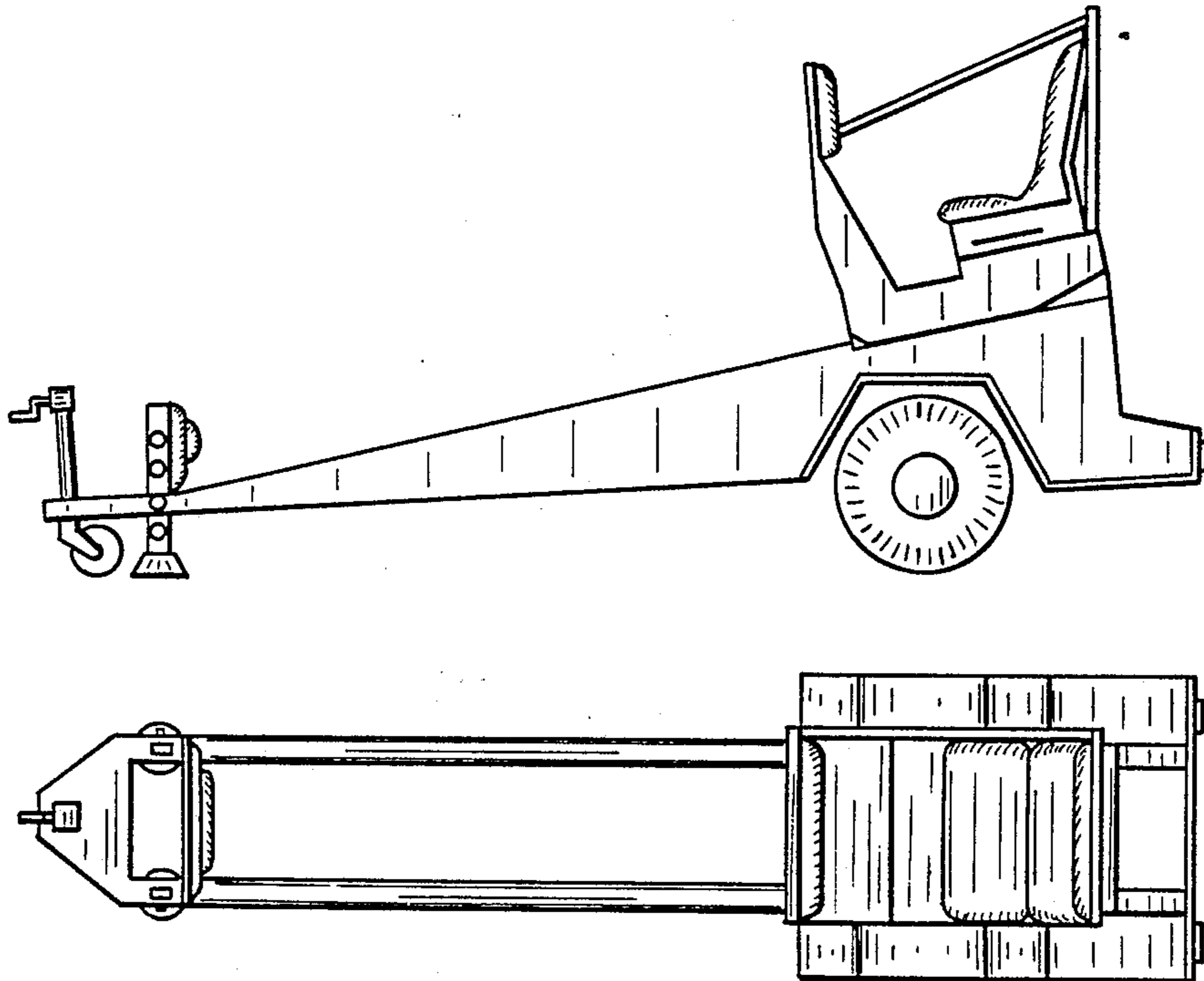

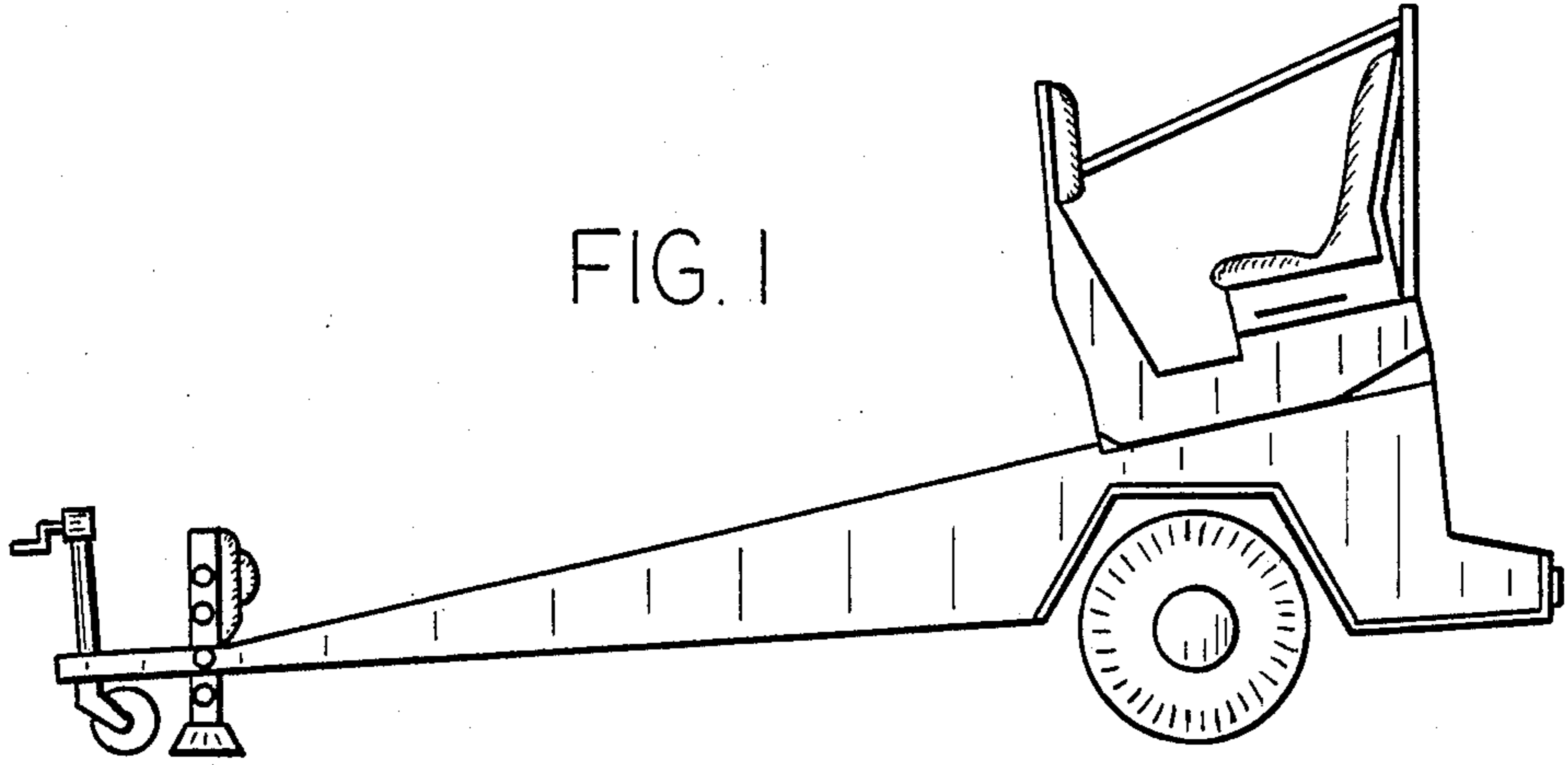

FIG. 1

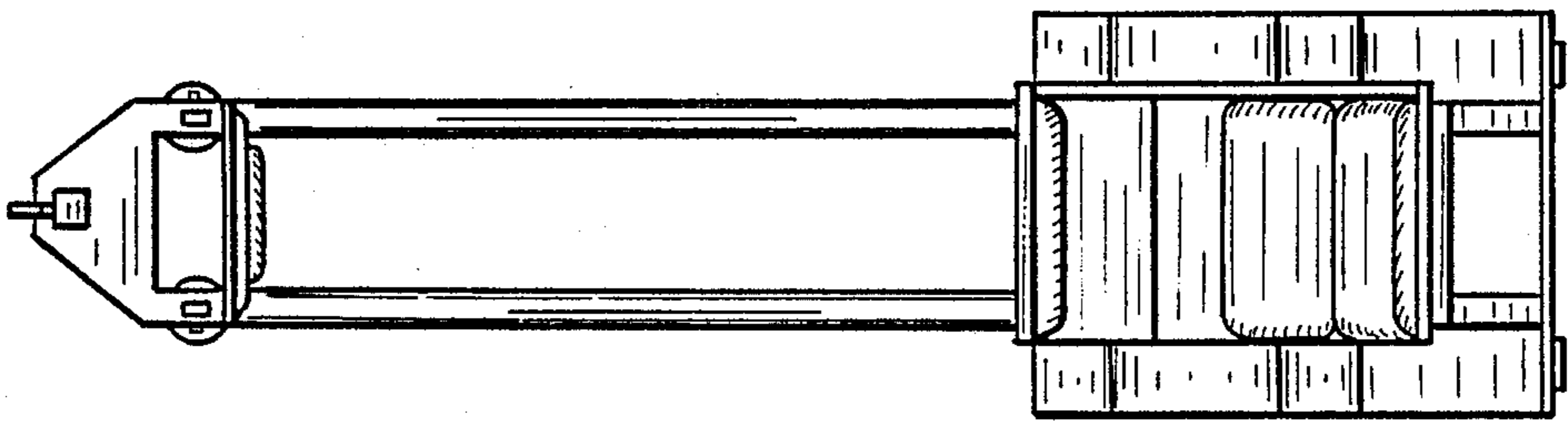

FIG. 4

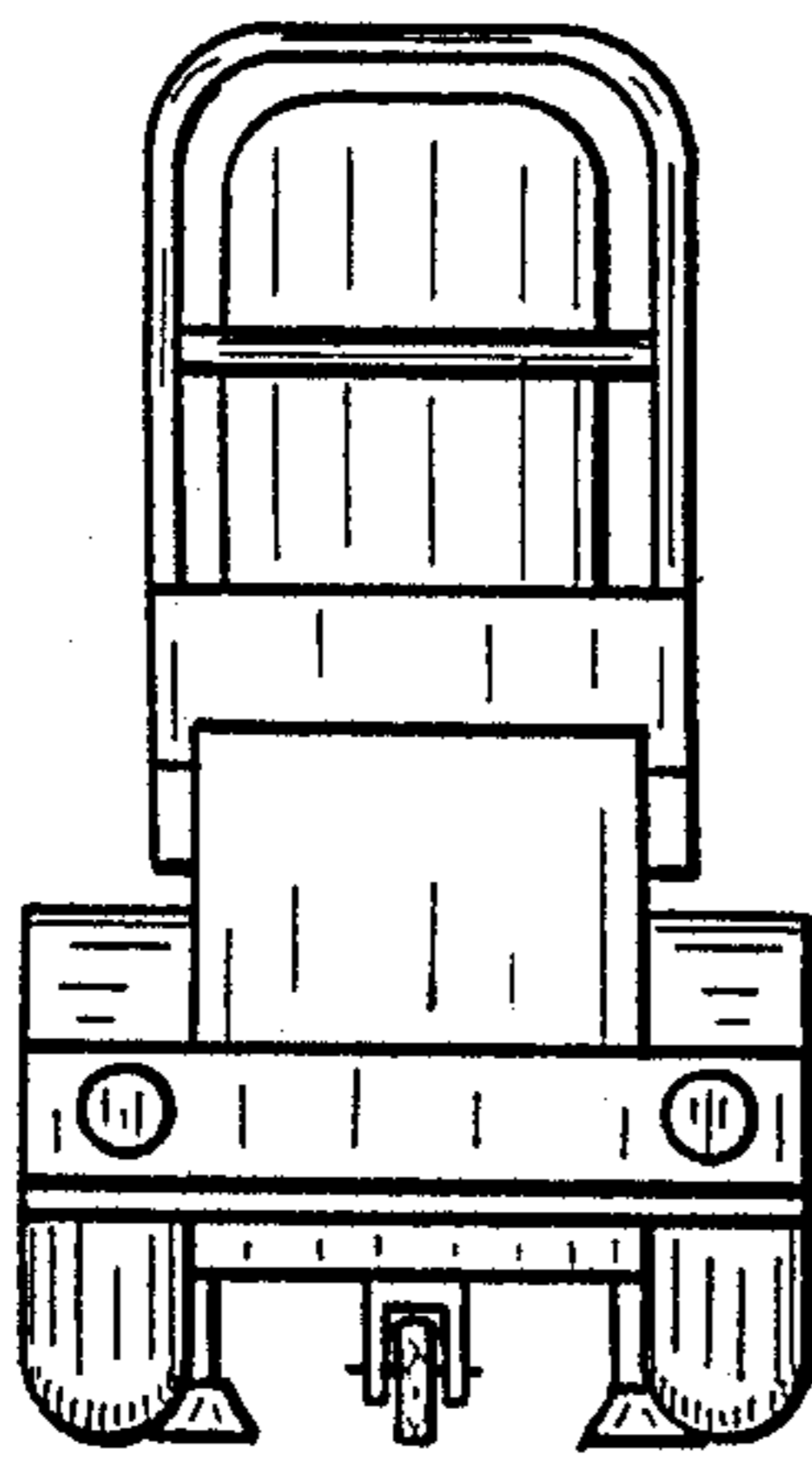

FIG. 2

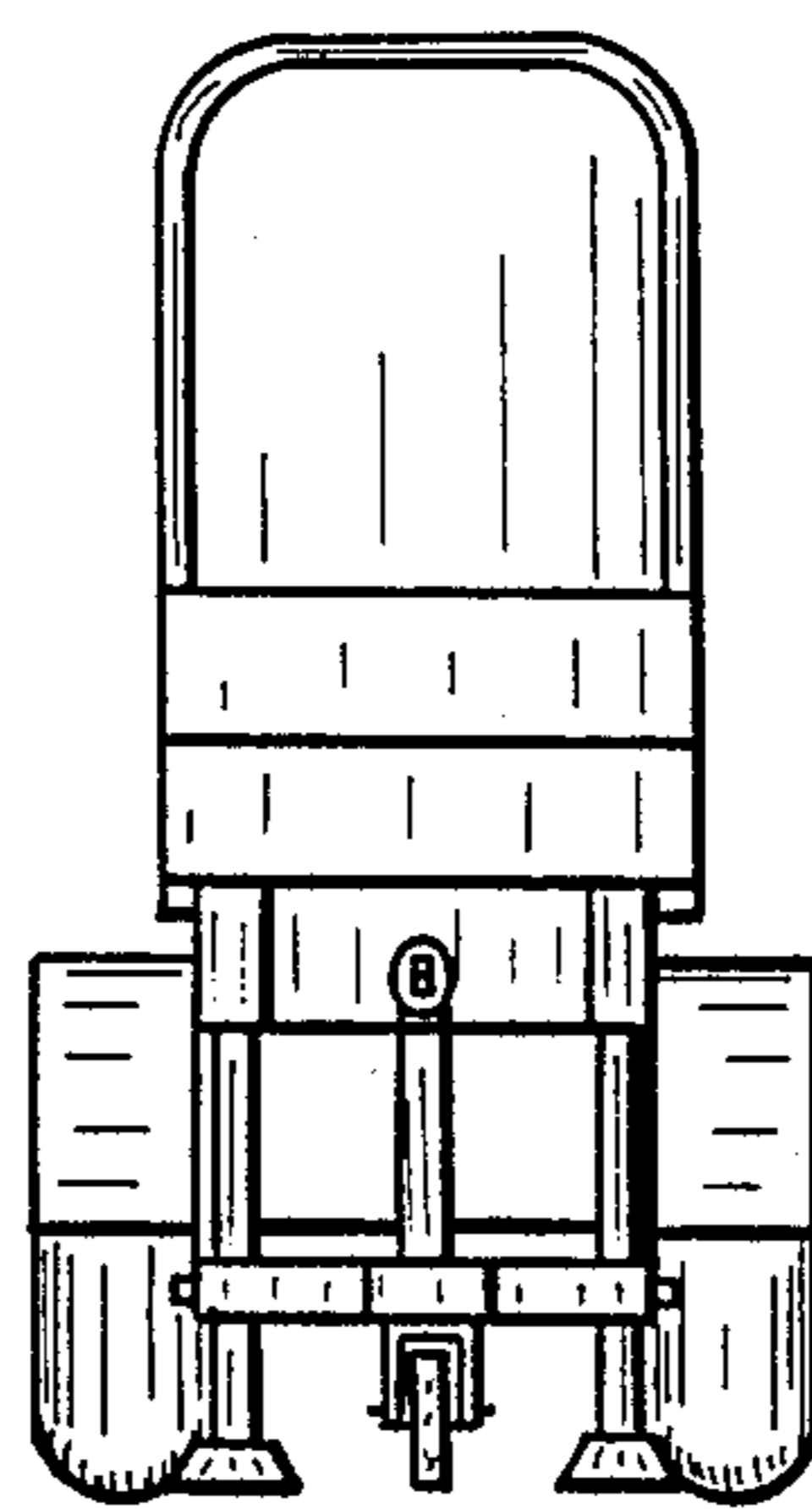

FIG. 3