

[54] **BABY CARRIAGE**

[75] Inventor: **Kenzou Kassai**, Osaka, Japan
 [73] Assignee: **Aprica Kassai Kabushikikaisha**,
 Osaka, Japan
 [**] Term: **14 Years**
 [21] Appl. No.: **942,864**
 [22] Filed: **Dec. 17, 1986**

[30] **Foreign Application Priority Data**

Jun. 18, 1986 [JP] Japan 61-23727
 Sep. 25, 1986 [JP] Japan 61-38015
 Dec. 1, 1986 [JP] Japan 61-47505
 [52] U.S. Cl. **D12/129**
 [58] Field of Search D12/129, 128, 130;
 280/642, 643, 644, 42, 647, 648, 649, 650;
 297/458, 459, 460, DIG. 4

[56] **References Cited**

U.S. PATENT DOCUMENTS

D. 266,236 9/1982 Nakao et al. D12/129
 D. 288,544 3/1987 Nakao et al. D12/129
 D. 293,661 1/1988 Nakao et al. D12/129
 D. 293,662 1/1988 Nakao D12/129
 D. 296,313 6/1988 Kujawski D12/129
 4,597,116 7/1986 Kassai D12/129
 4,660,850 4/1987 Nakao et al. 280/650

Primary Examiner—Wallace R. Burke
Assistant Examiner—Kay H. Chin
Attorney, Agent, or Firm—W. G. Fasse; D. H. Kane, Jr.

[57] **CLAIM**

The ornamental design for a baby carriage, as shown and described.

DESCRIPTION

FIG. 1 is a front elevational view of a baby carriage showing my new design;
 FIG. 2 is a rear elevational view of FIG. 1;
 FIG. 3 is a top plan view of FIG. 1;
 FIG. 4 is a bottom plan view of FIG. 1;
 FIG. 5 is a left side elevational view of FIG. 1;
 FIG. 6 is a right side elevational view of FIG. 1;
 FIG. 7 is a front perspective view of FIG. 1;
 FIG. 8 is a front perspective view of FIG. 1 in a folded condition;
 FIG. 9 is a front perspective view of FIG. 1 wherein a backrest portion is brought in an inclined condition;
 FIG. 10 is a front perspective view of FIG. 1 wherein a backrest portion is brought in an inclined condition and a push rod is rotated to a front position;
 FIG. 11 is a front elevational view of a second embodiment of the baby carriage;
 FIG. 12 is a rear elevational view of FIG. 11;
 FIG. 13 is a top plan view of FIG. 11;
 FIG. 14 is a bottom plan view of FIG. 11;
 FIG. 15 is a left side elevational view of FIG. 11;
 FIG. 16 is a right side elevational view of FIG. 11;
 FIG. 17 is a front perspective view of FIG. 11;
 FIG. 18 is a front perspective view of FIG. 11 in a folded condition;
 FIG. 19 is a front elevational view of a third embodiment of the baby carriage;
 FIG. 20 is a rear elevational view of FIG. 19;
 FIG. 21 is a top plan view of FIG. 19;
 FIG. 22 is a bottom plan view of FIG. 19;
 FIG. 23 is a left side elevational view of FIG. 19;
 FIG. 24 is a right side elevational view of FIG. 19;
 FIG. 25 is a front perspective view of FIG. 19; and
 FIG. 26 is a front perspective view of FIG. 19 in a folded condition.

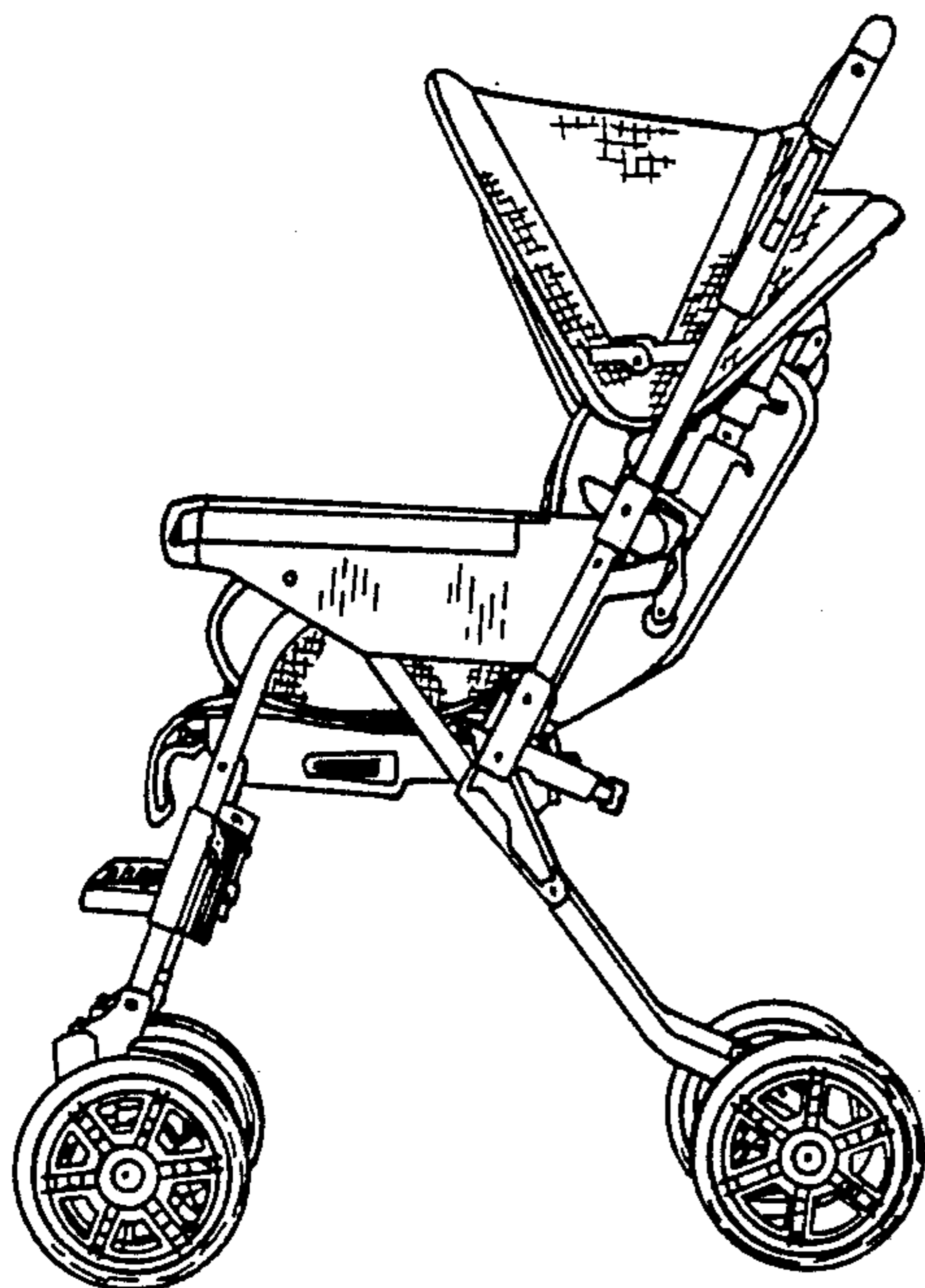

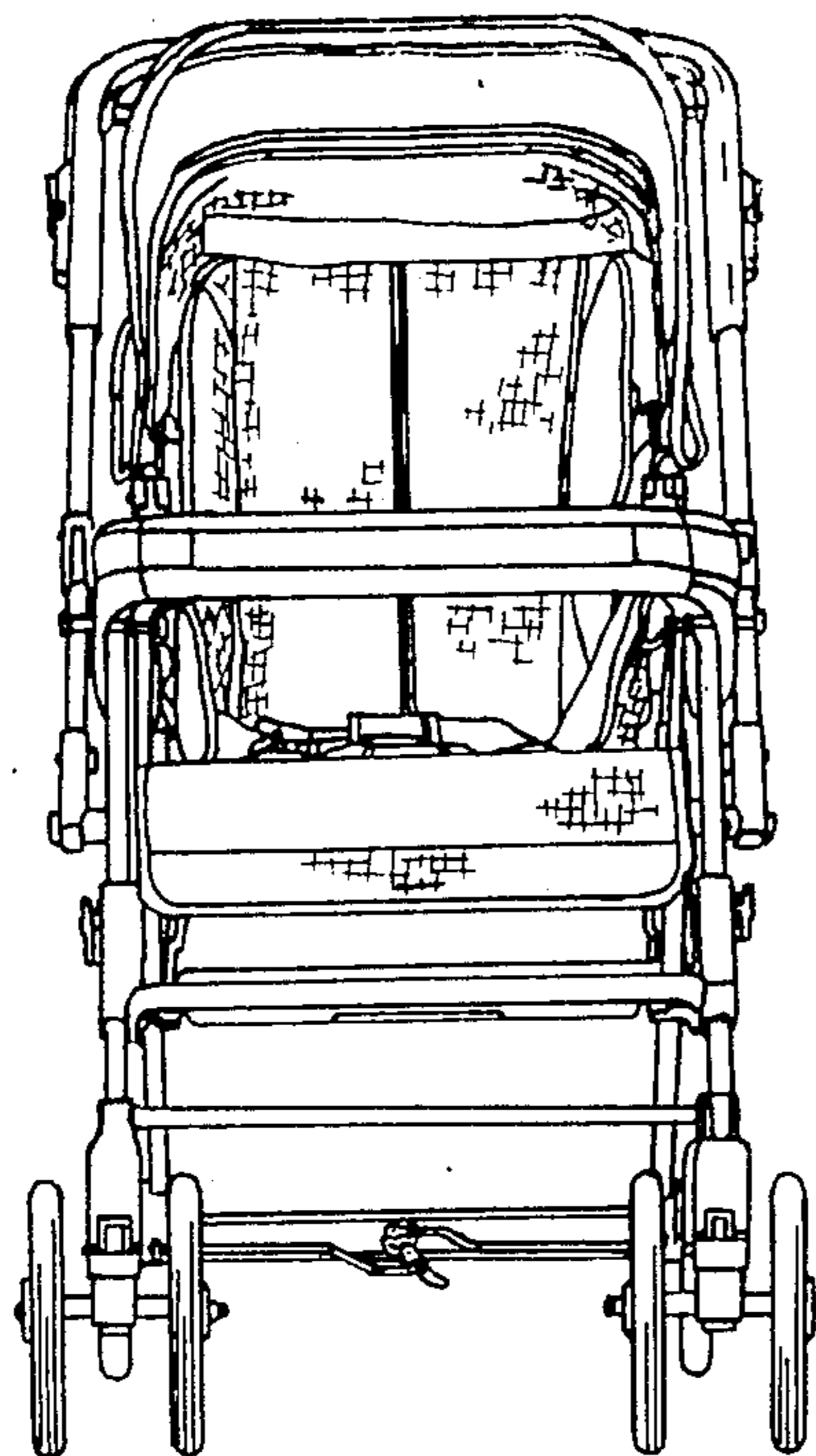

FIG. 1

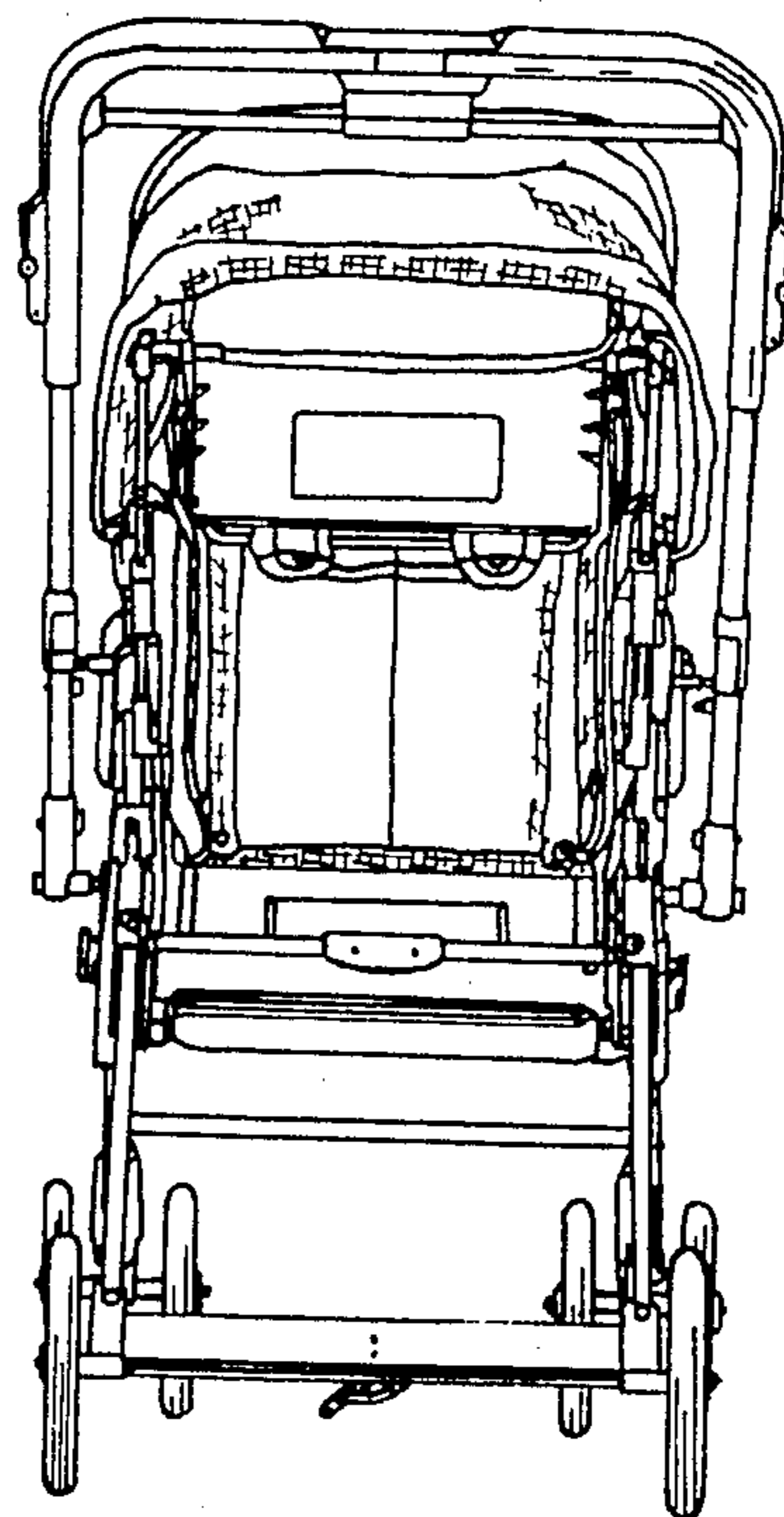

FIG. 2

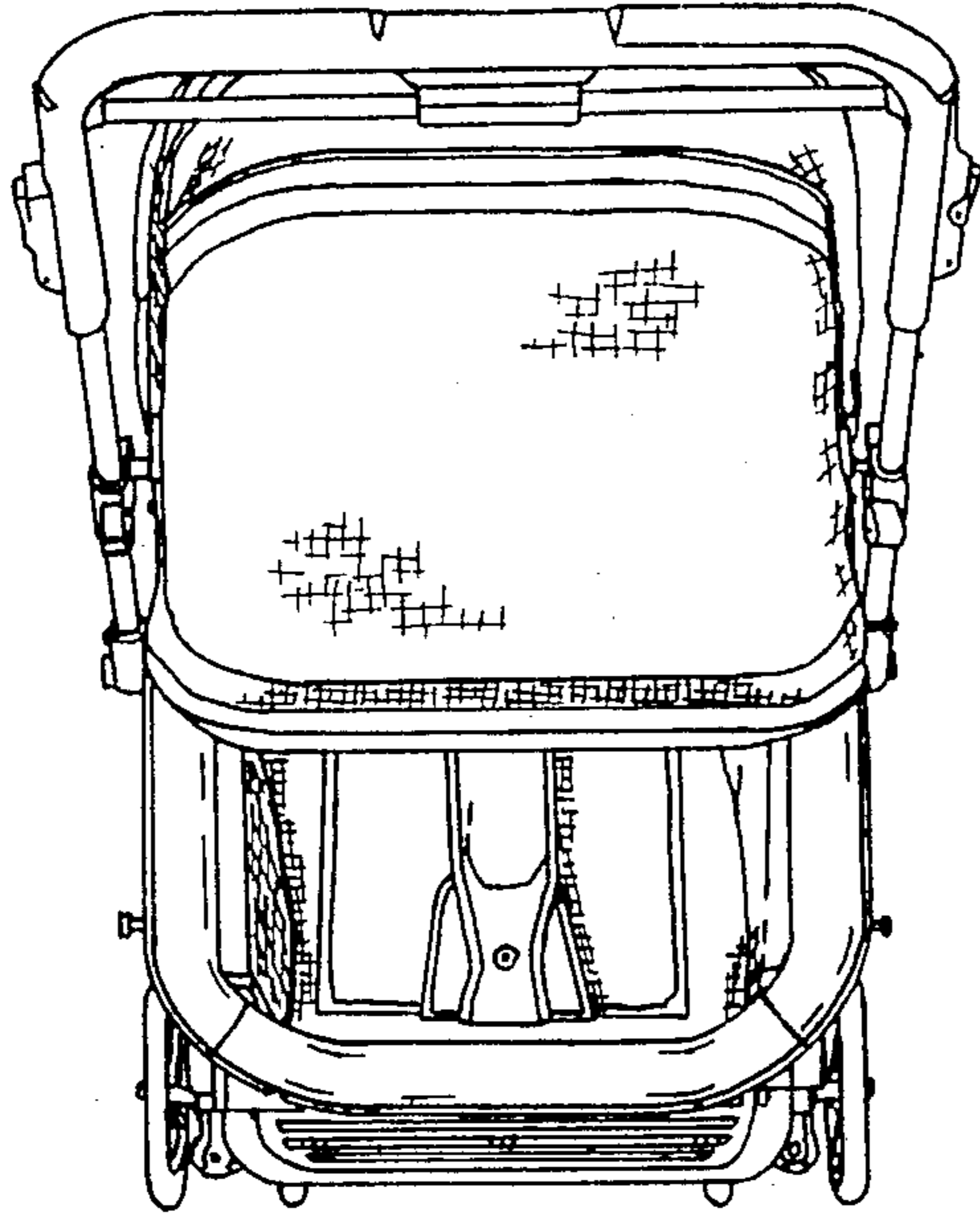

FIG. 3

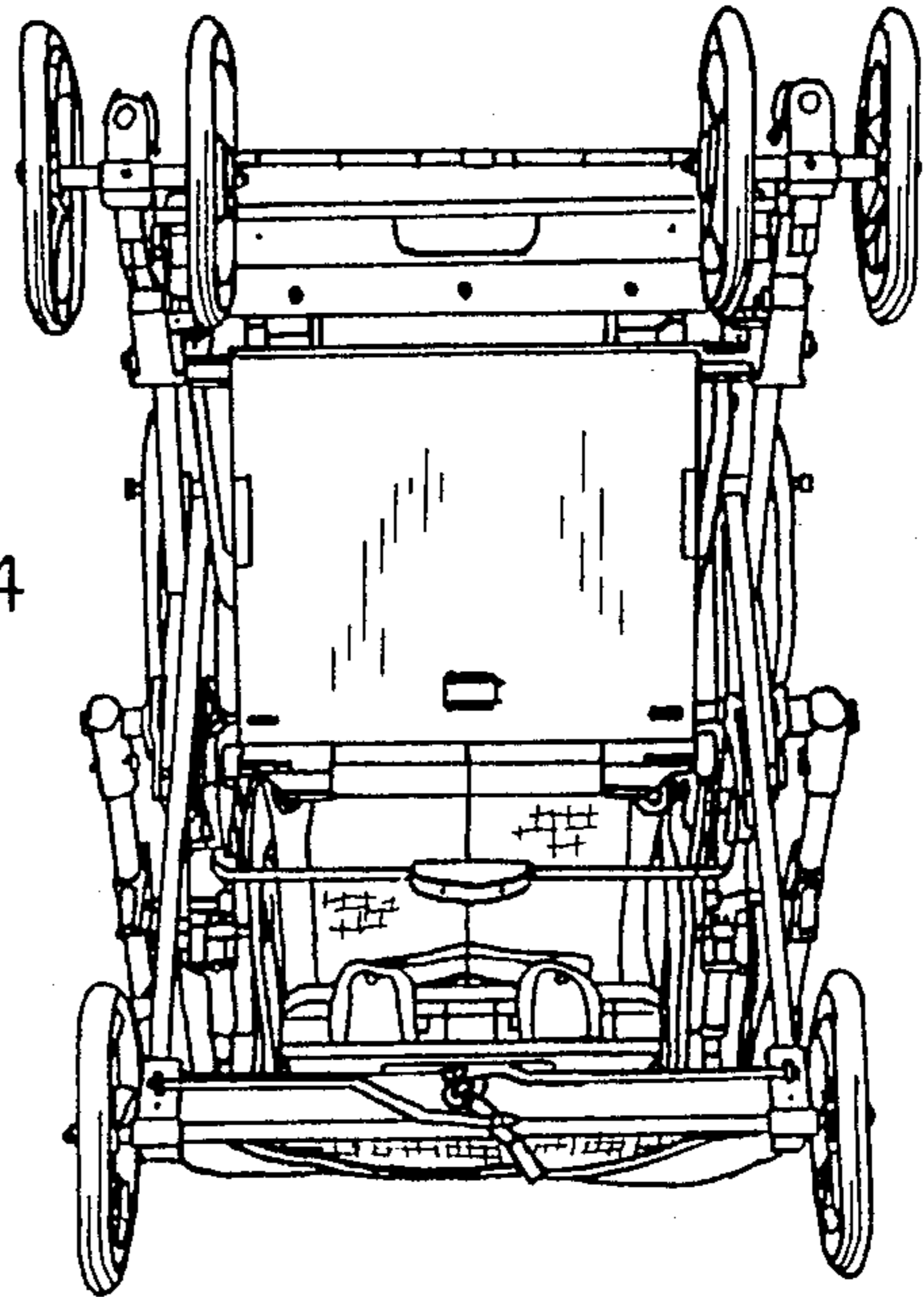

FIG. 4

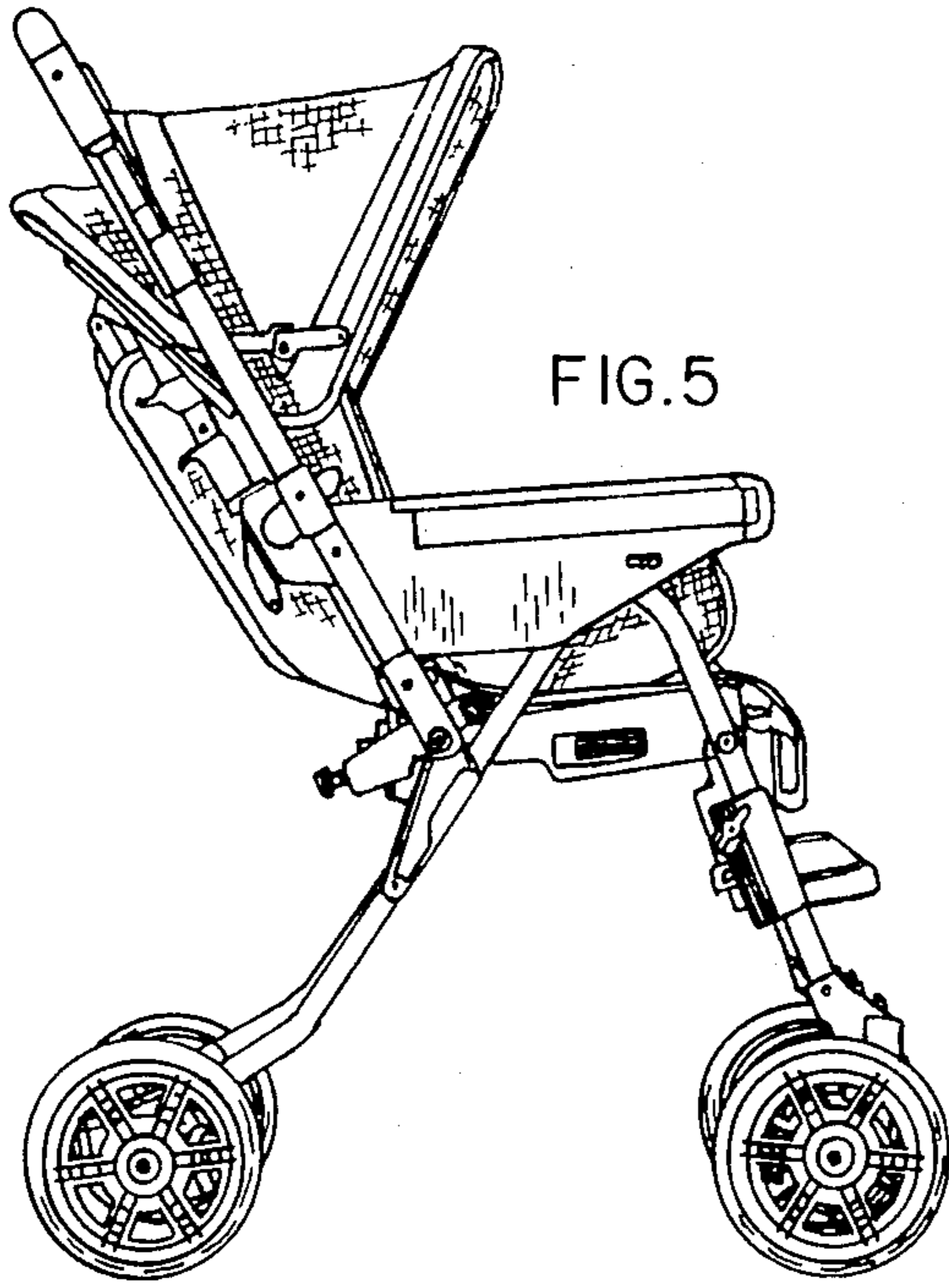

FIG. 5

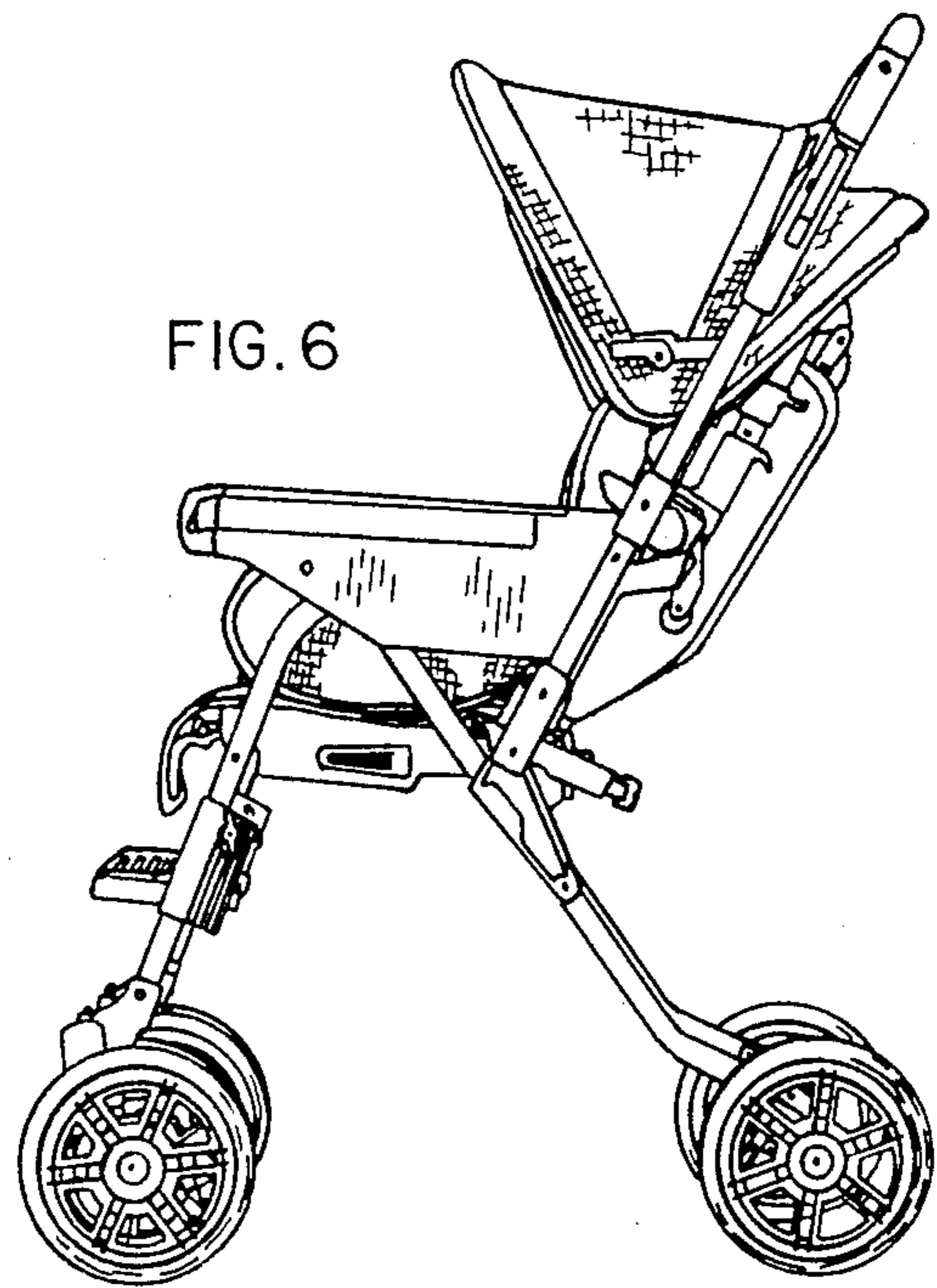

FIG. 6

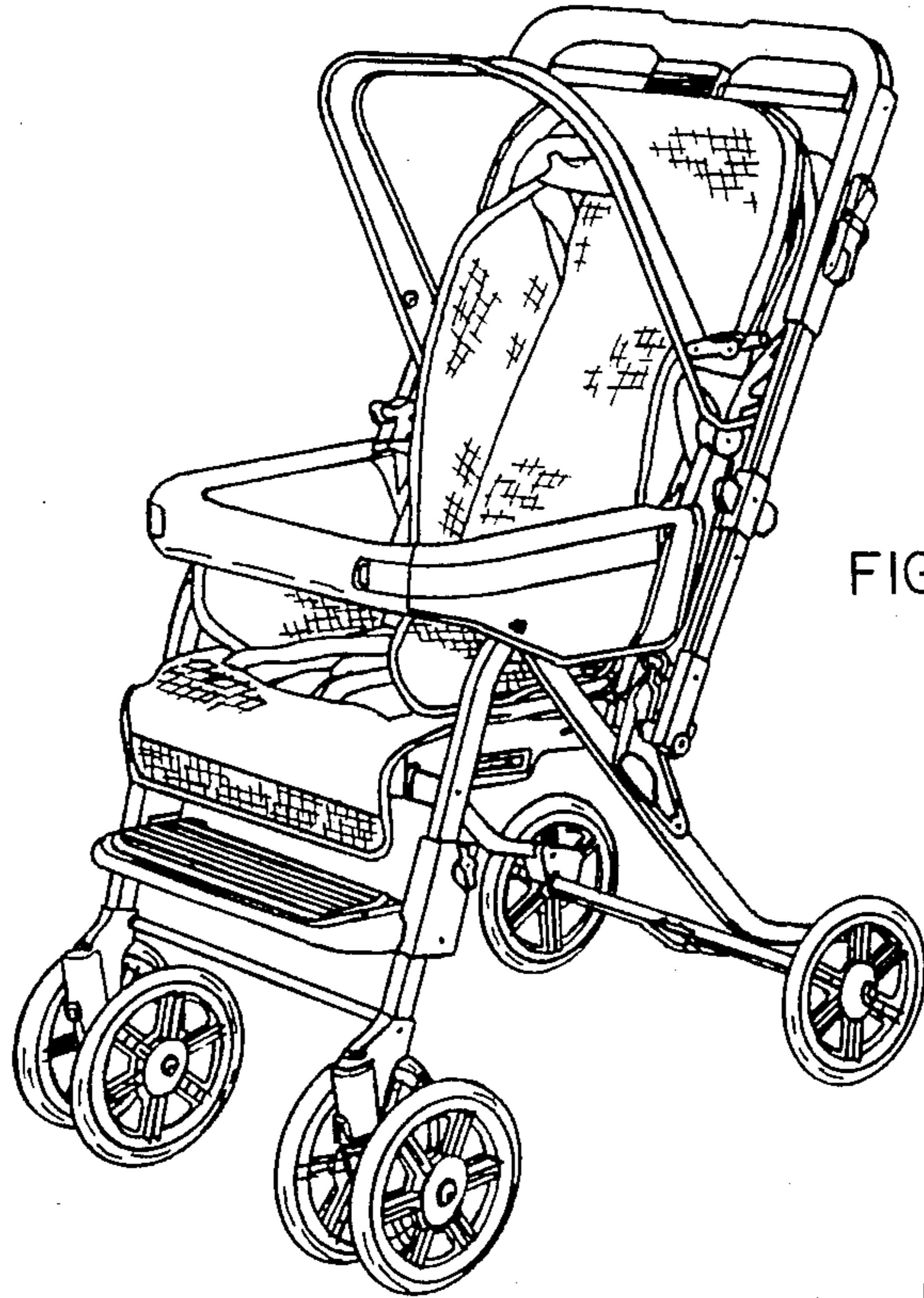

FIG. 7

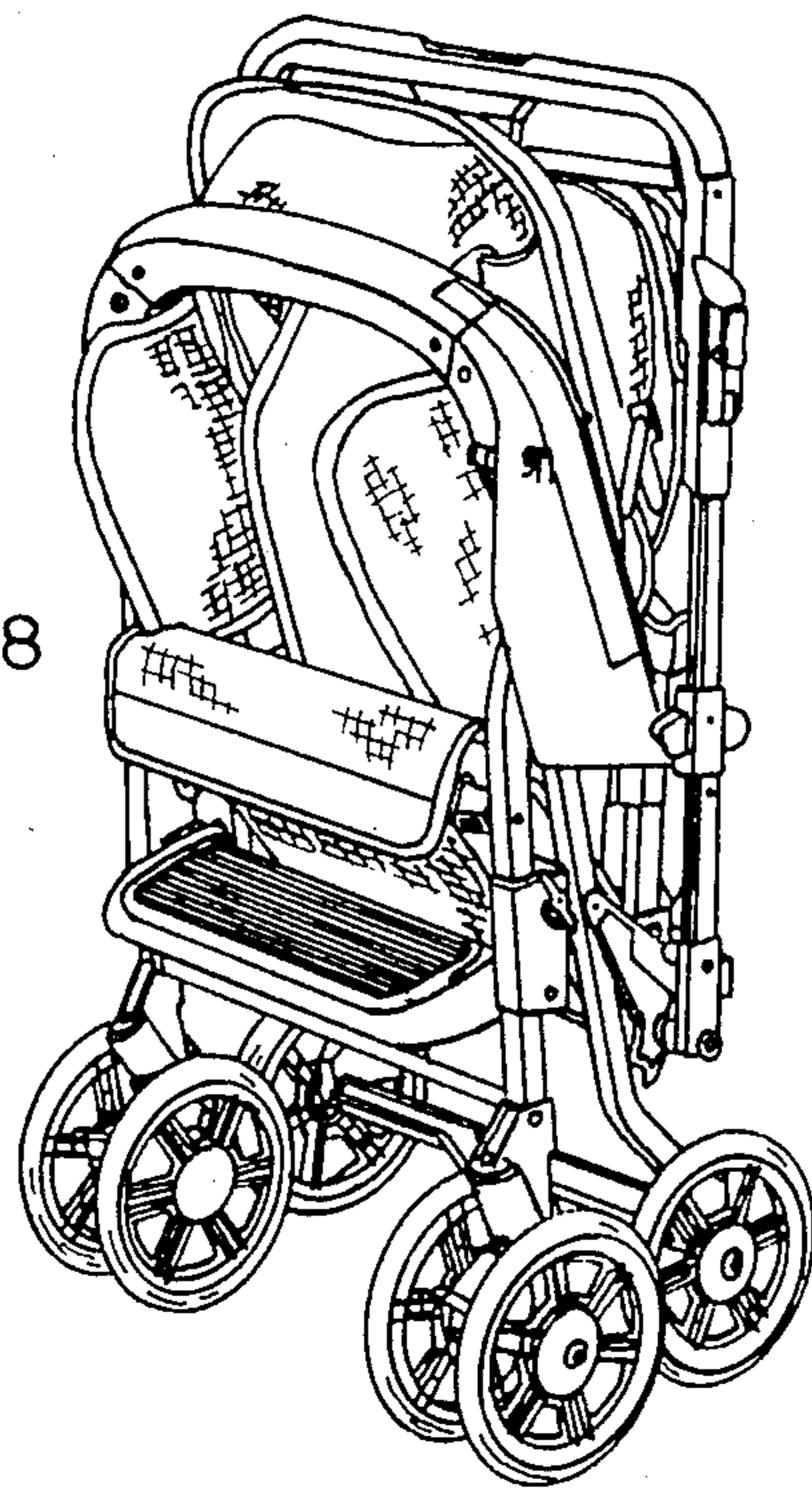

FIG. 8

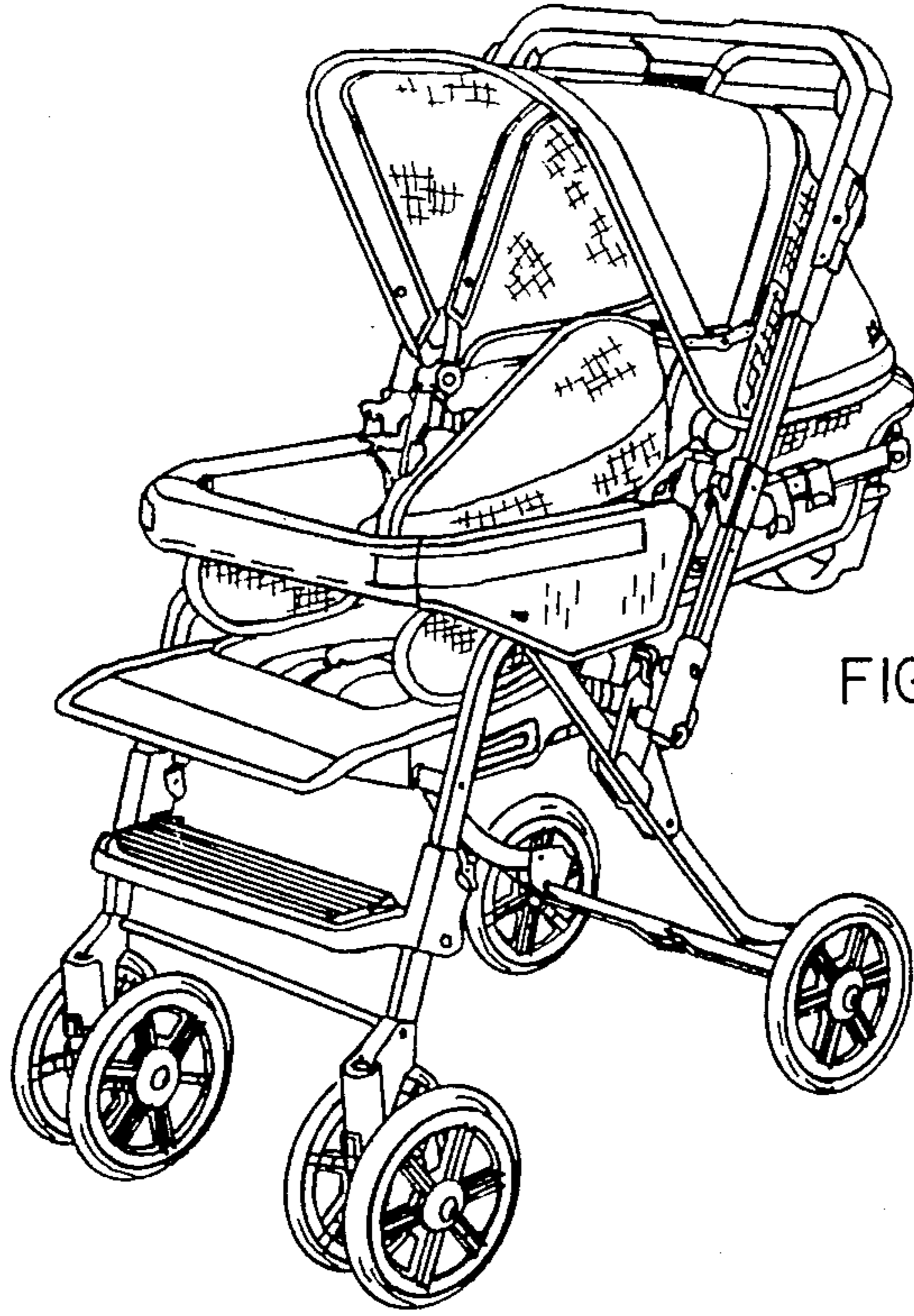

FIG. 9

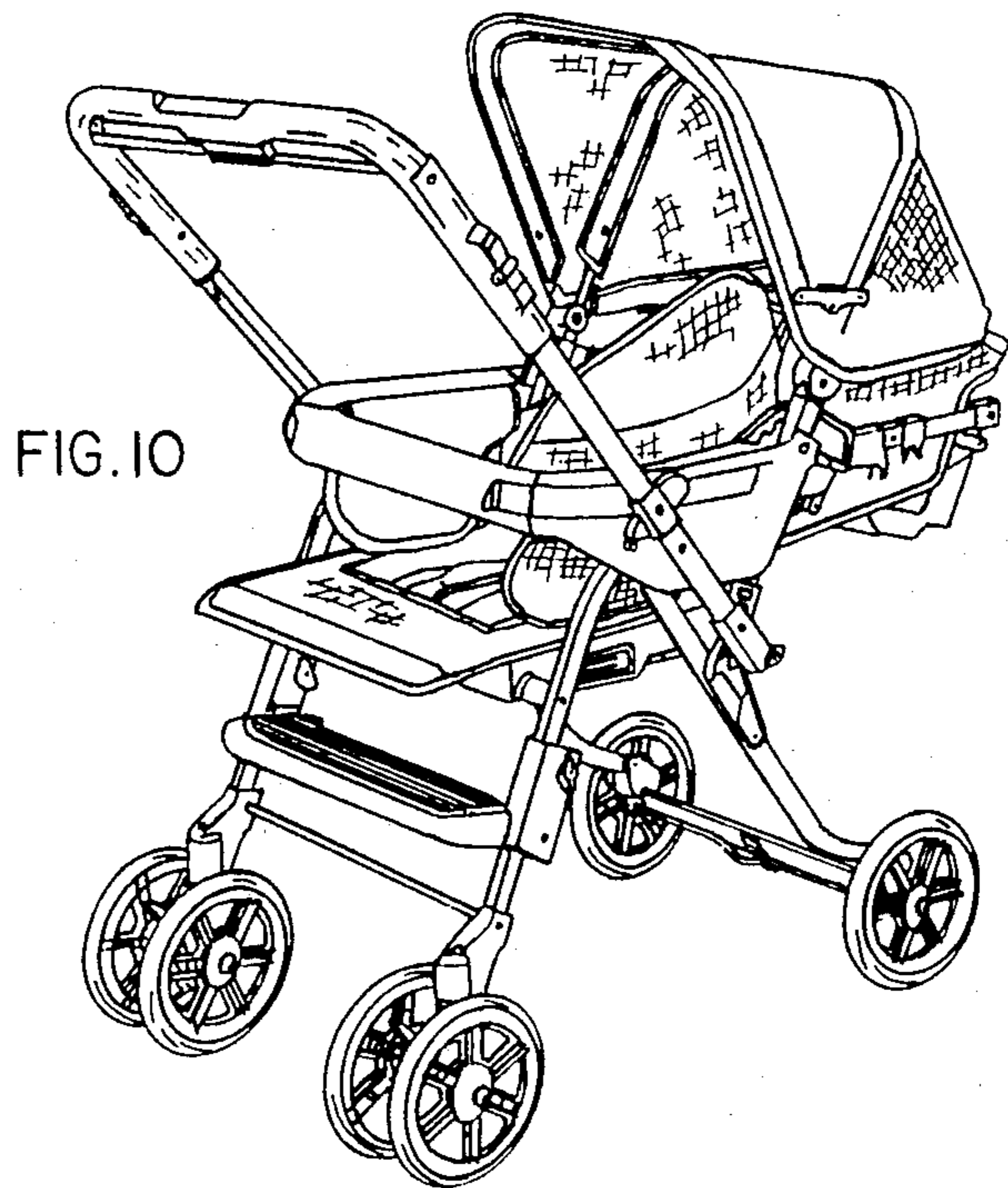

FIG. 10

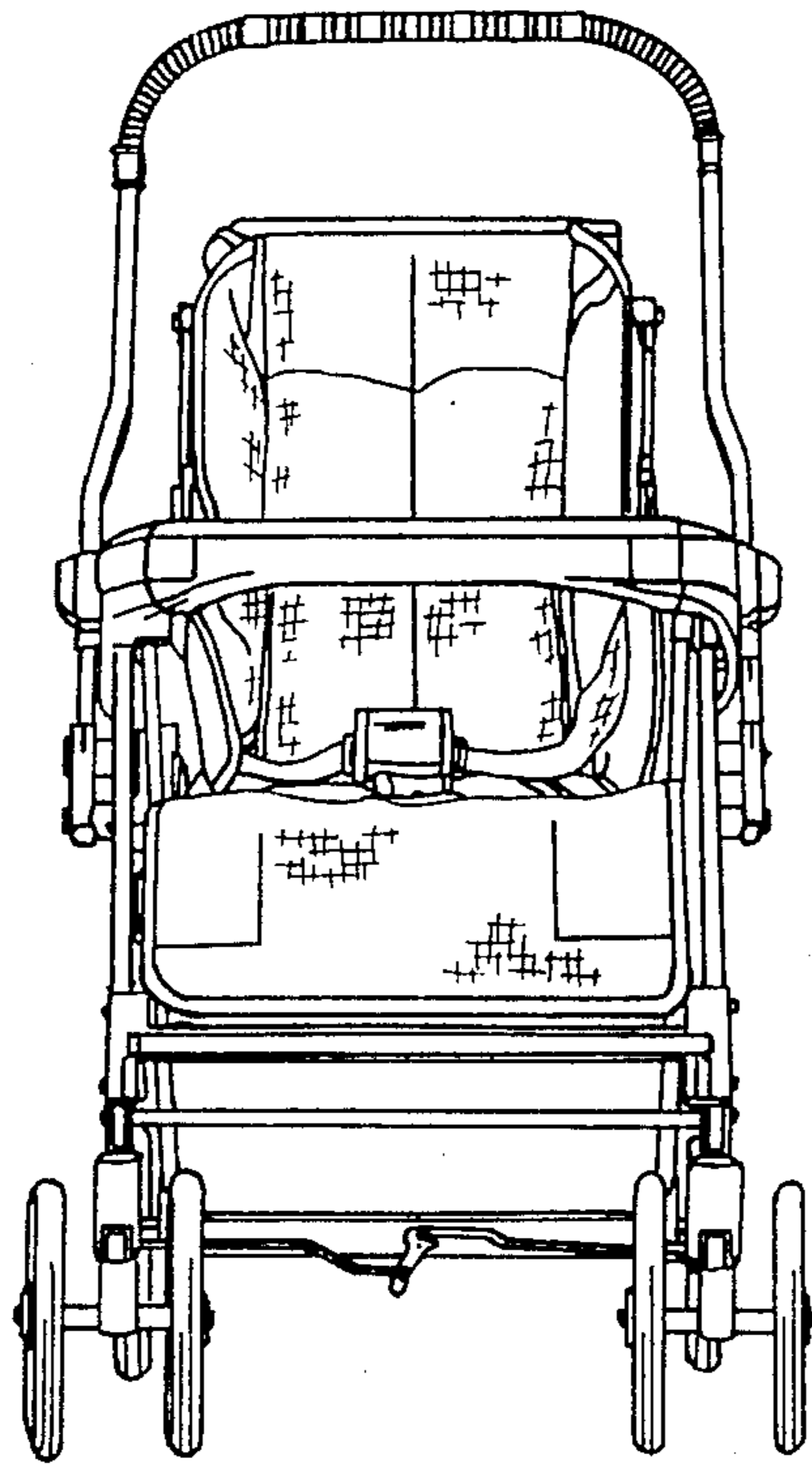

FIG. II

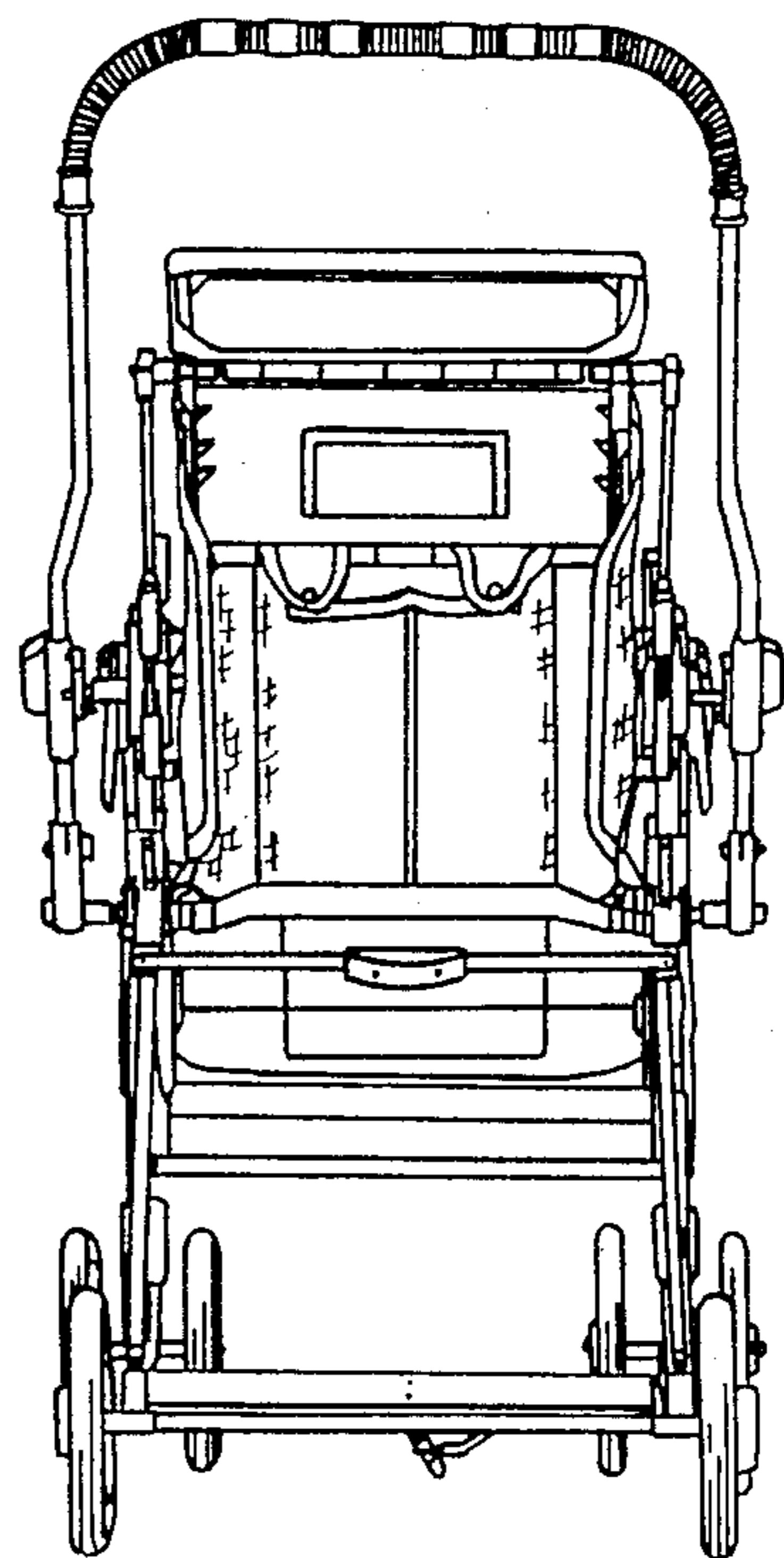

FIG. I2

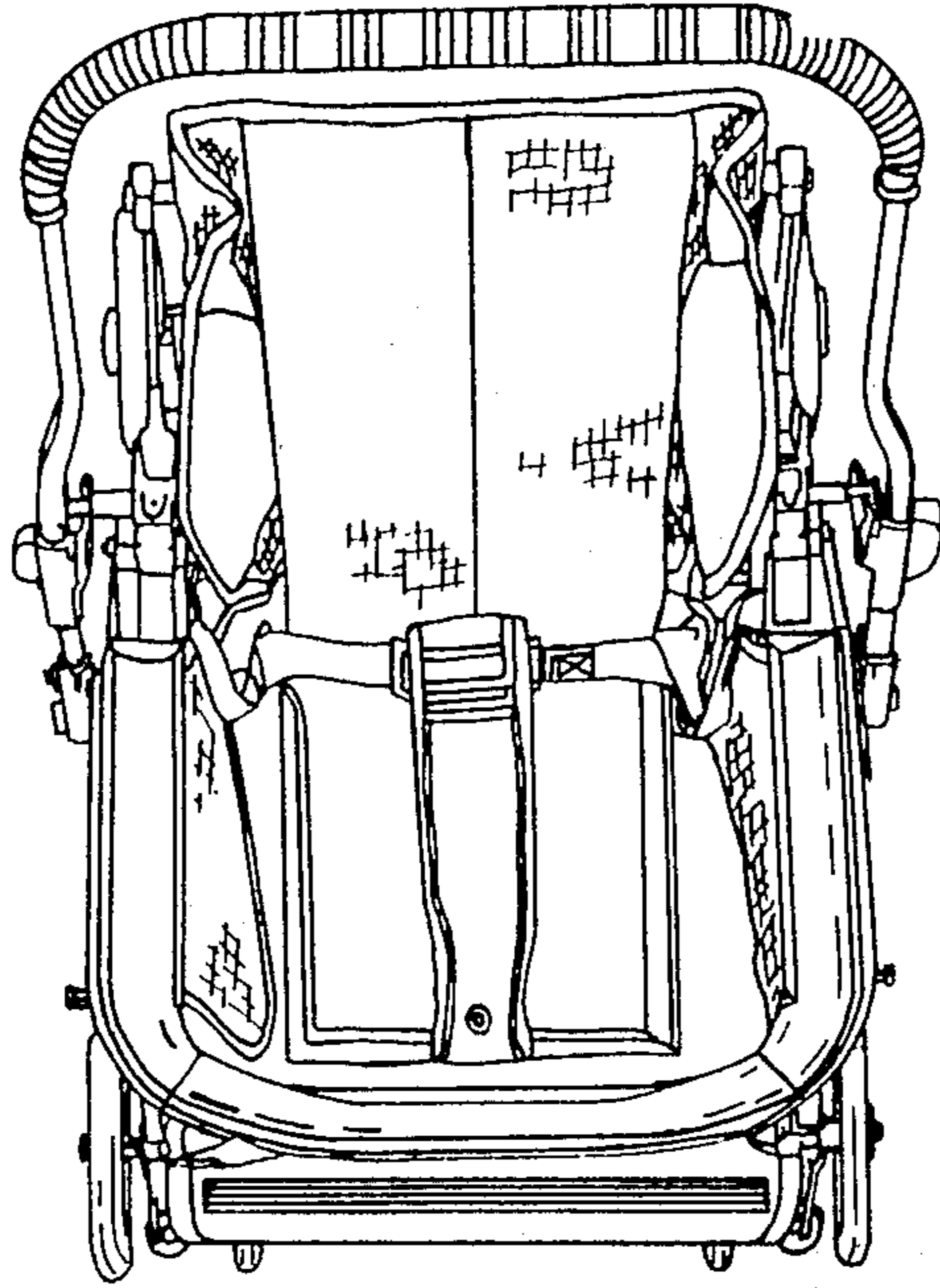

FIG. 13

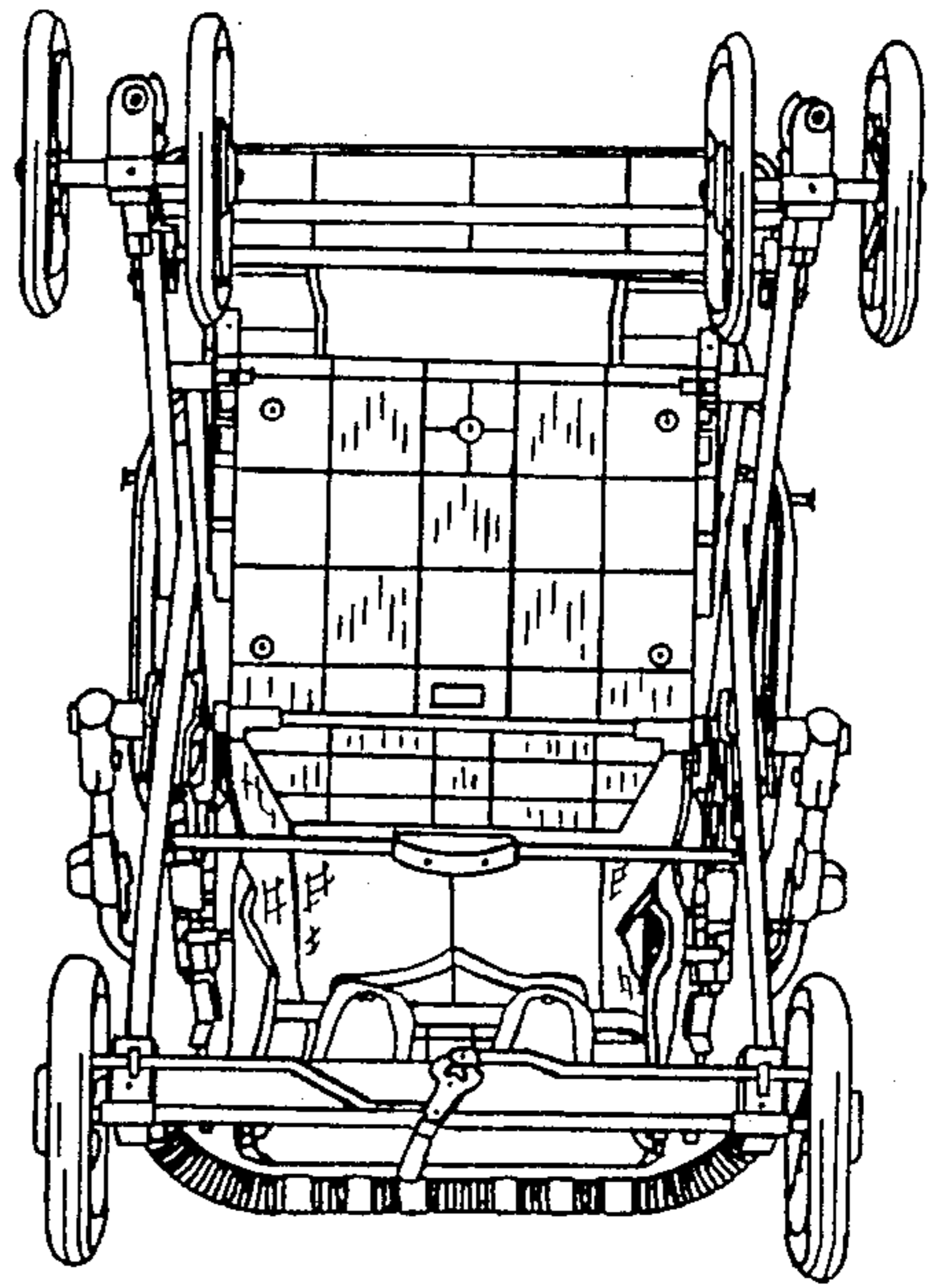
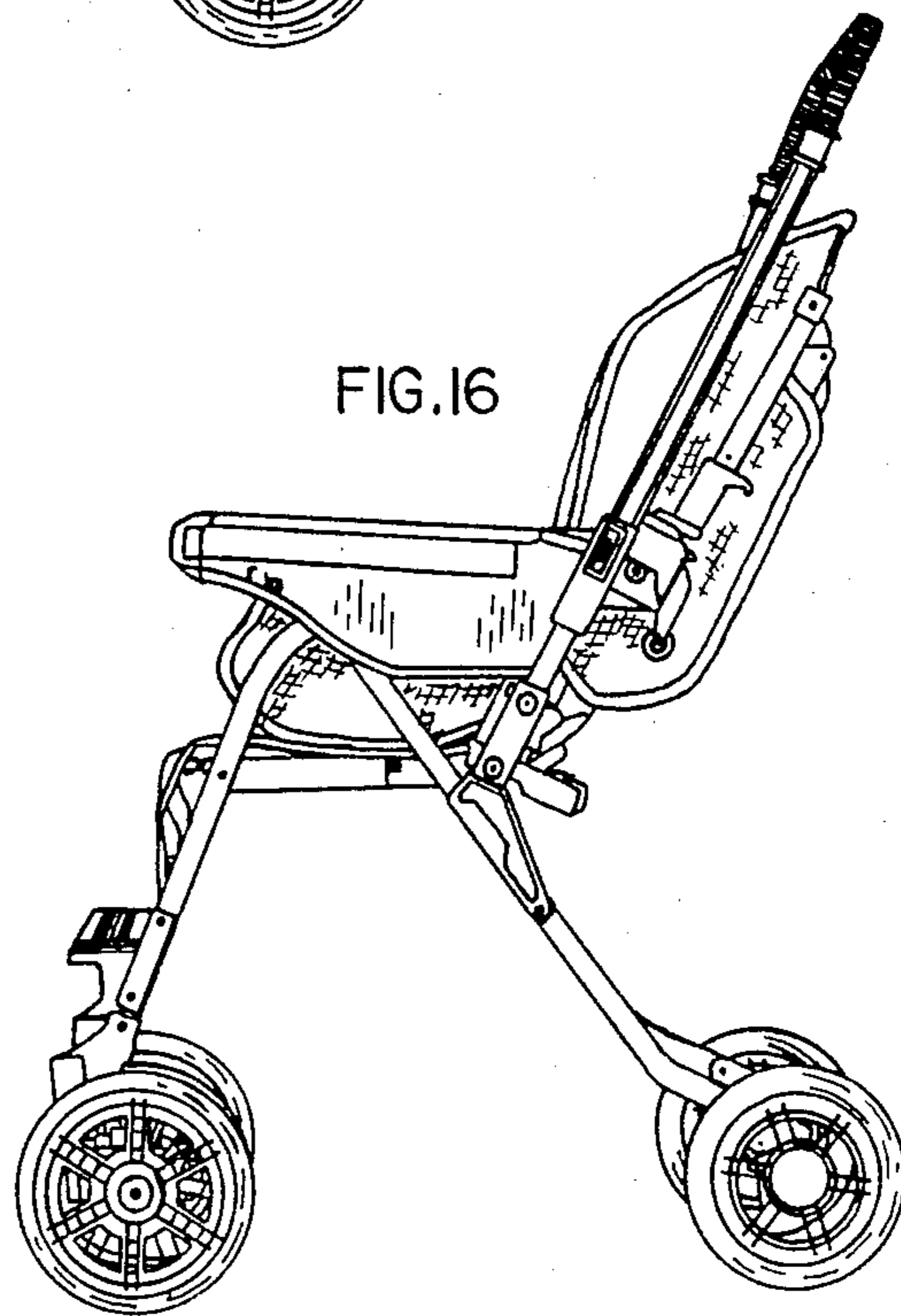
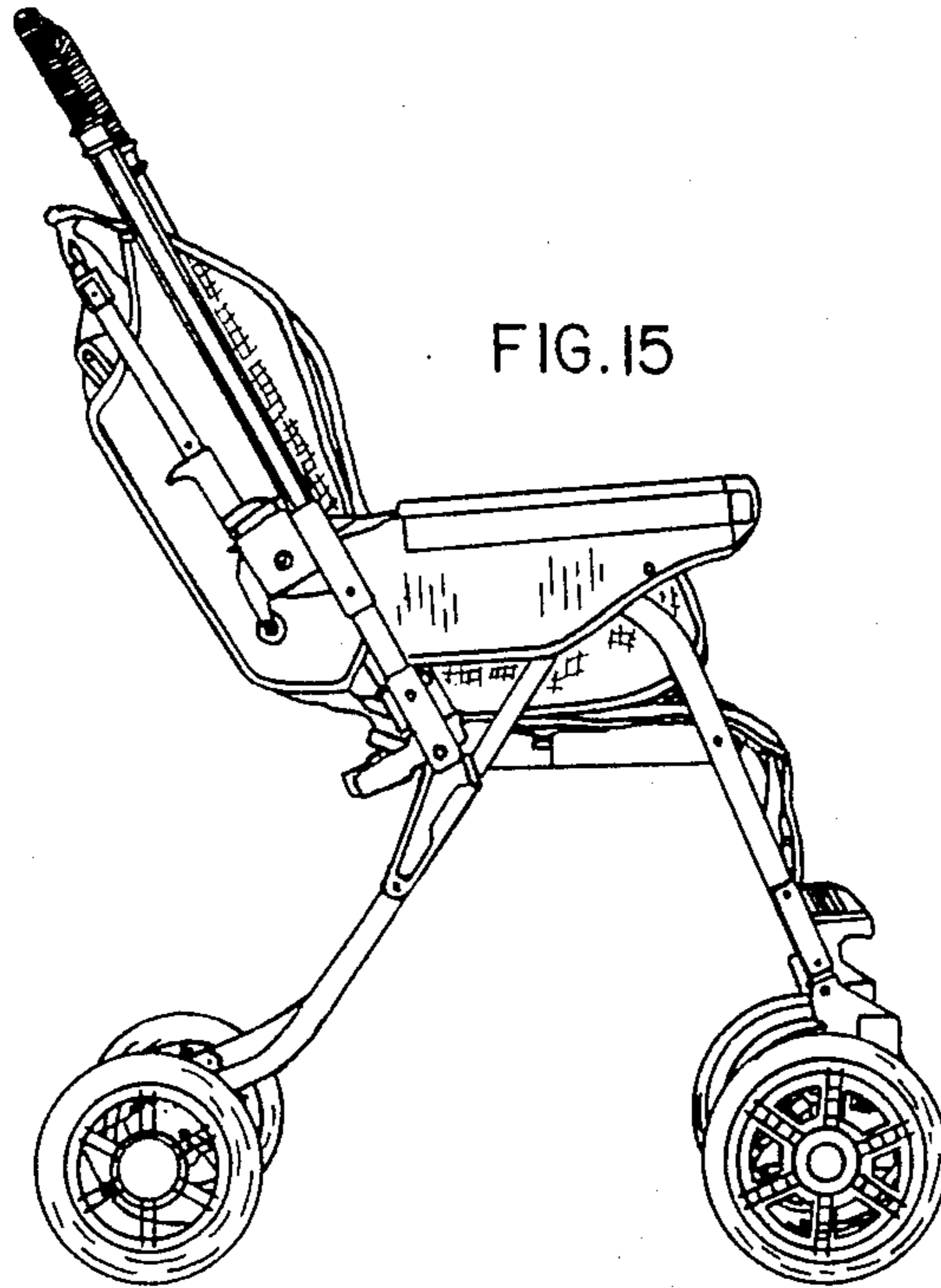

FIG. 14



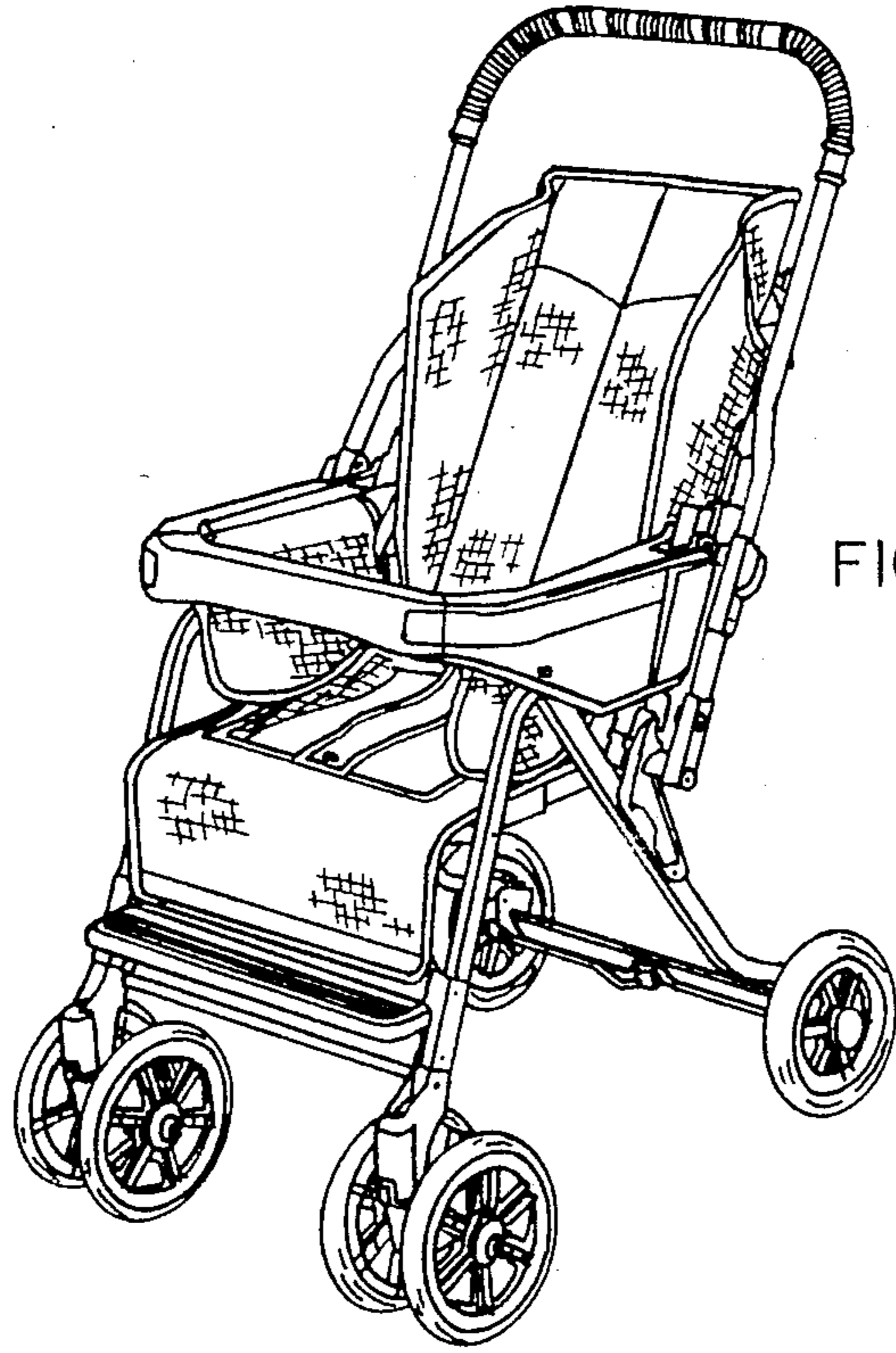

FIG. 17

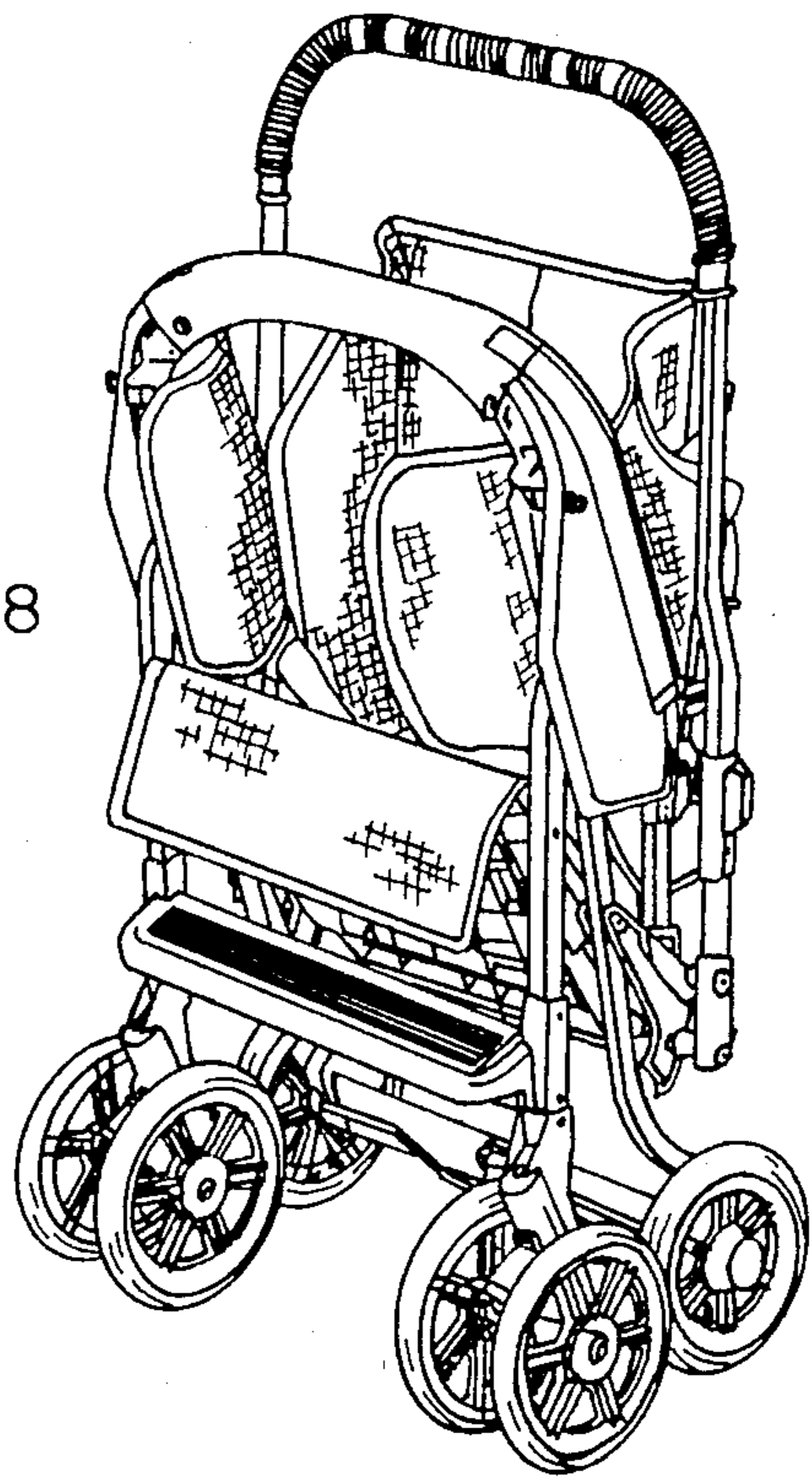

FIG. 18

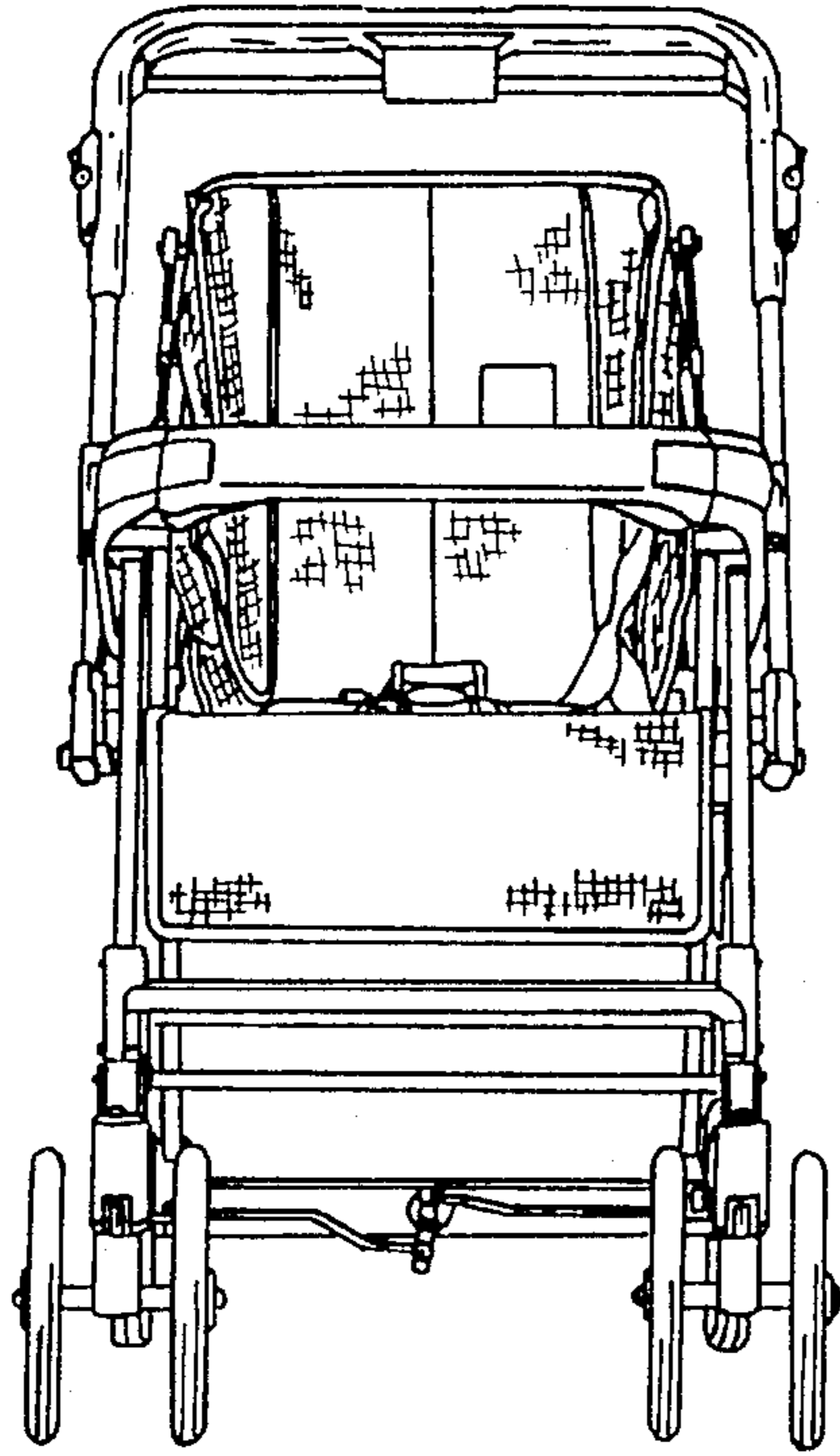

FIG. 19

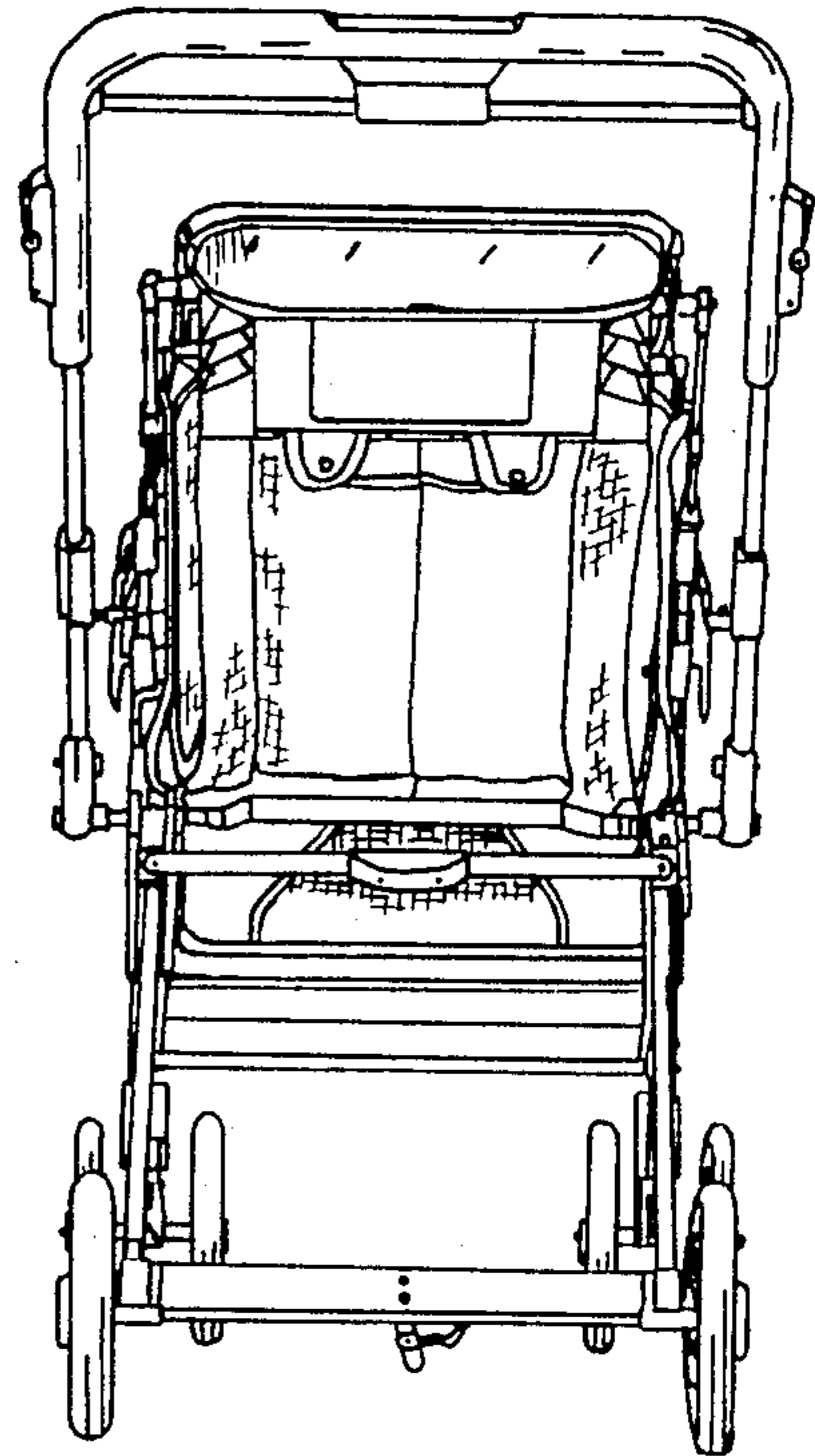

FIG. 20

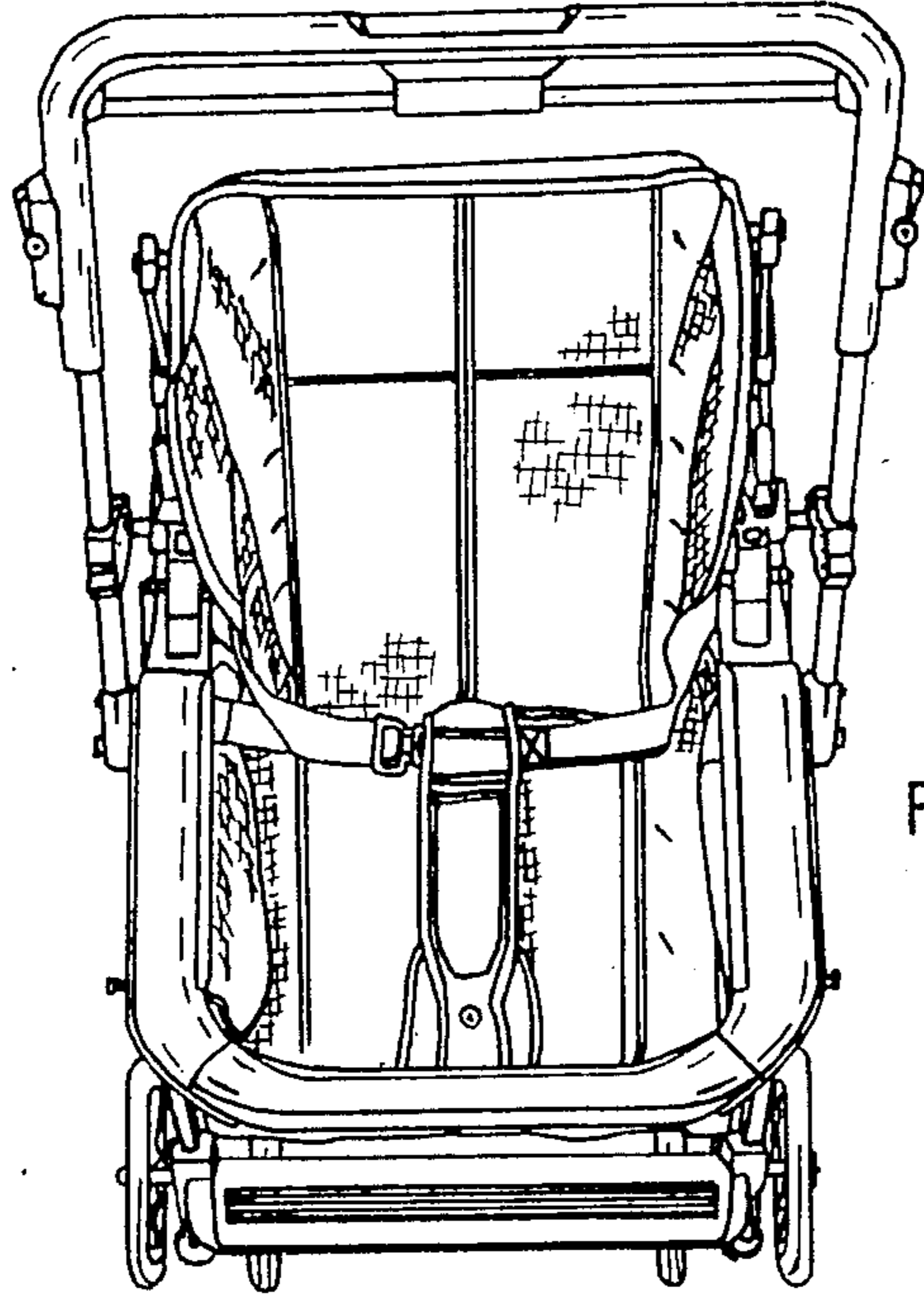

FIG. 21

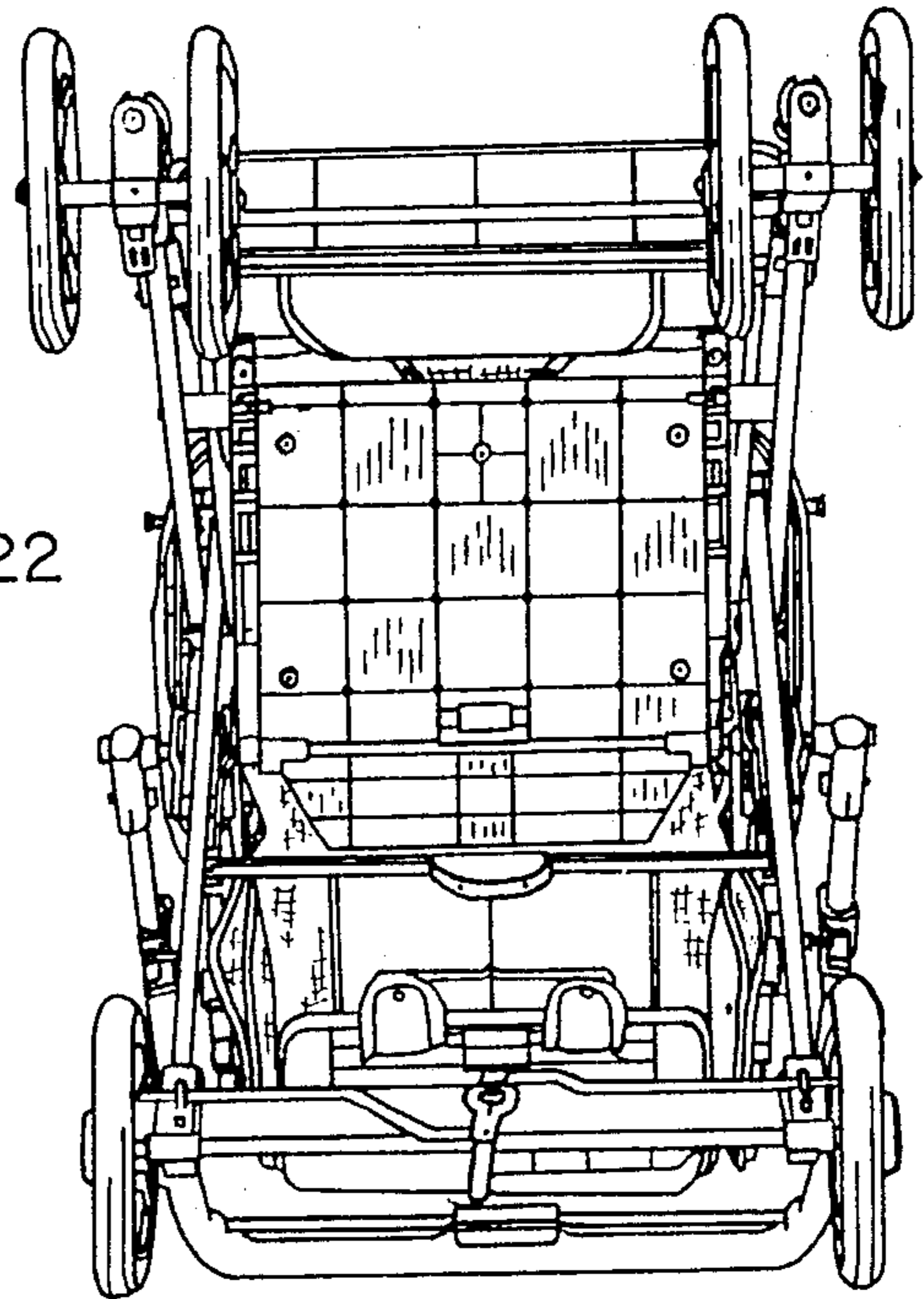

FIG. 22

FIG. 23

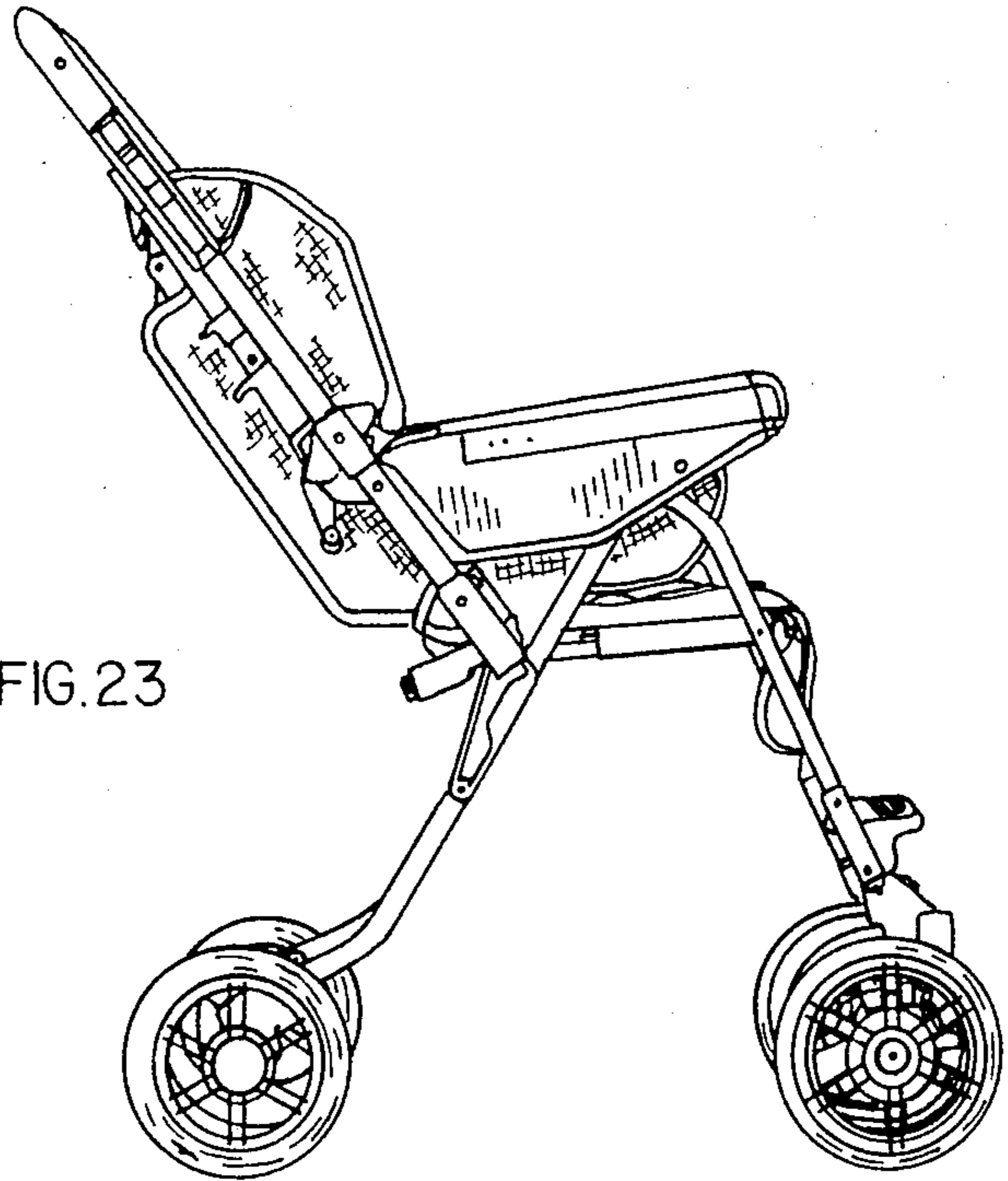
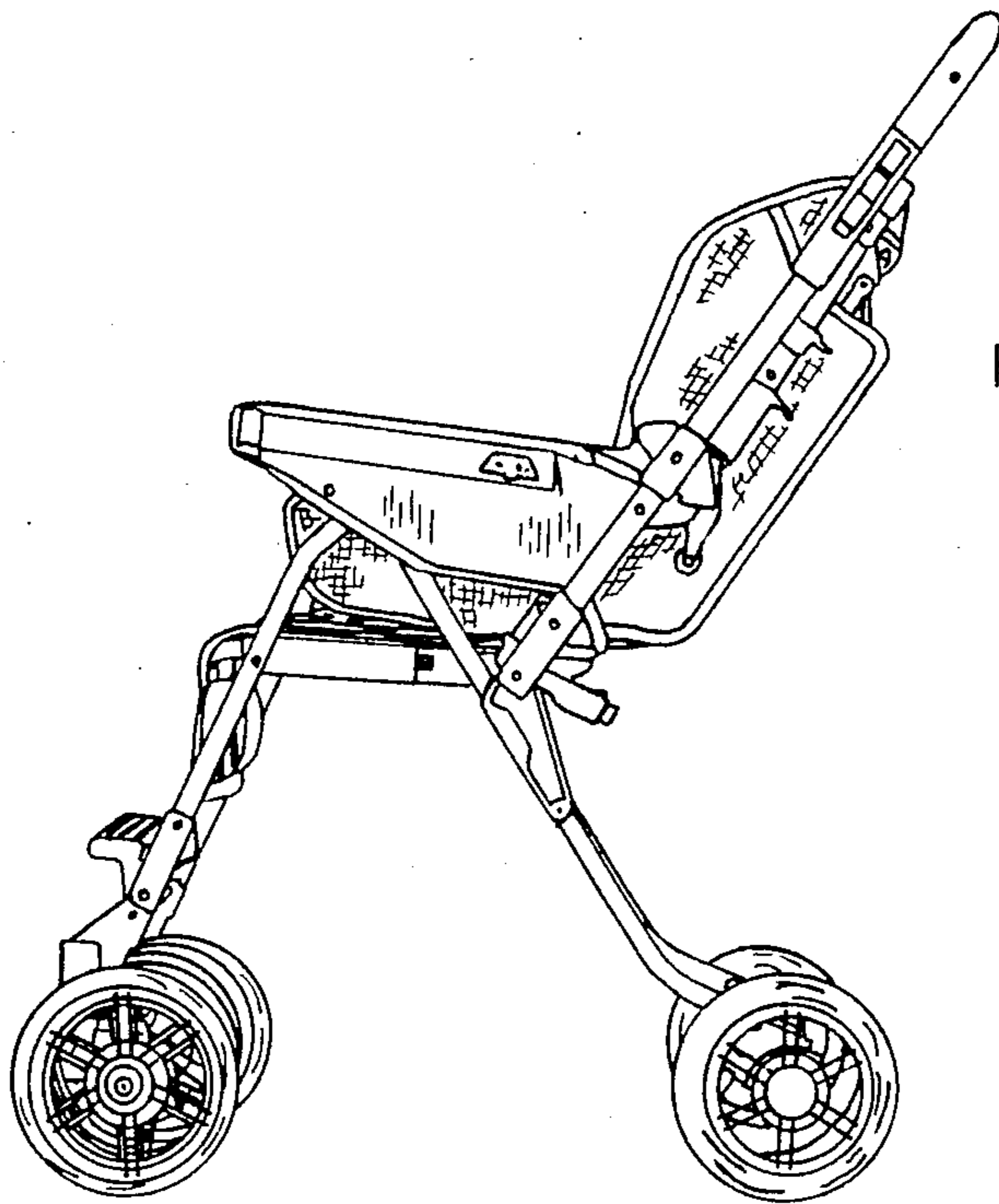

FIG. 24



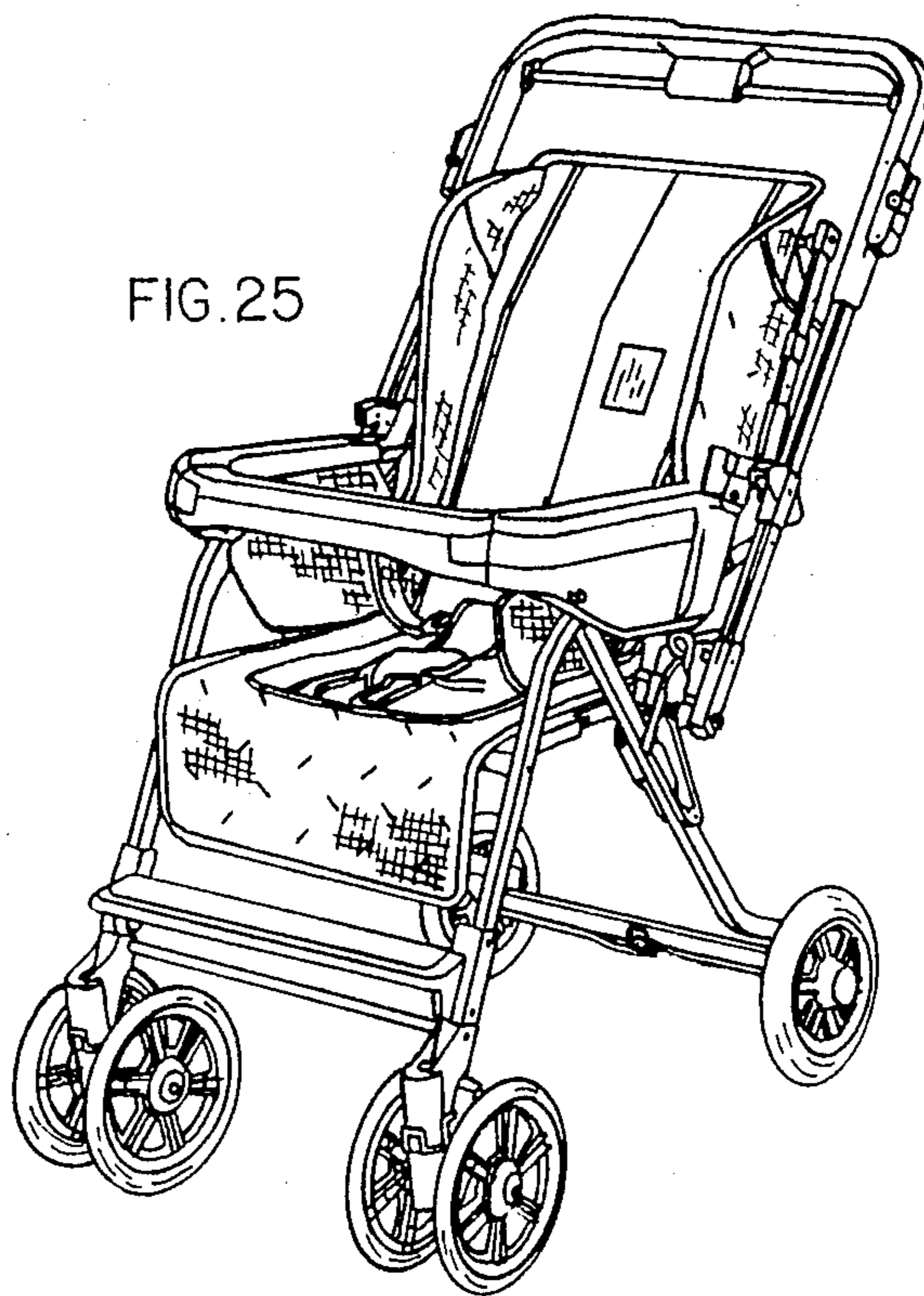

FIG. 25

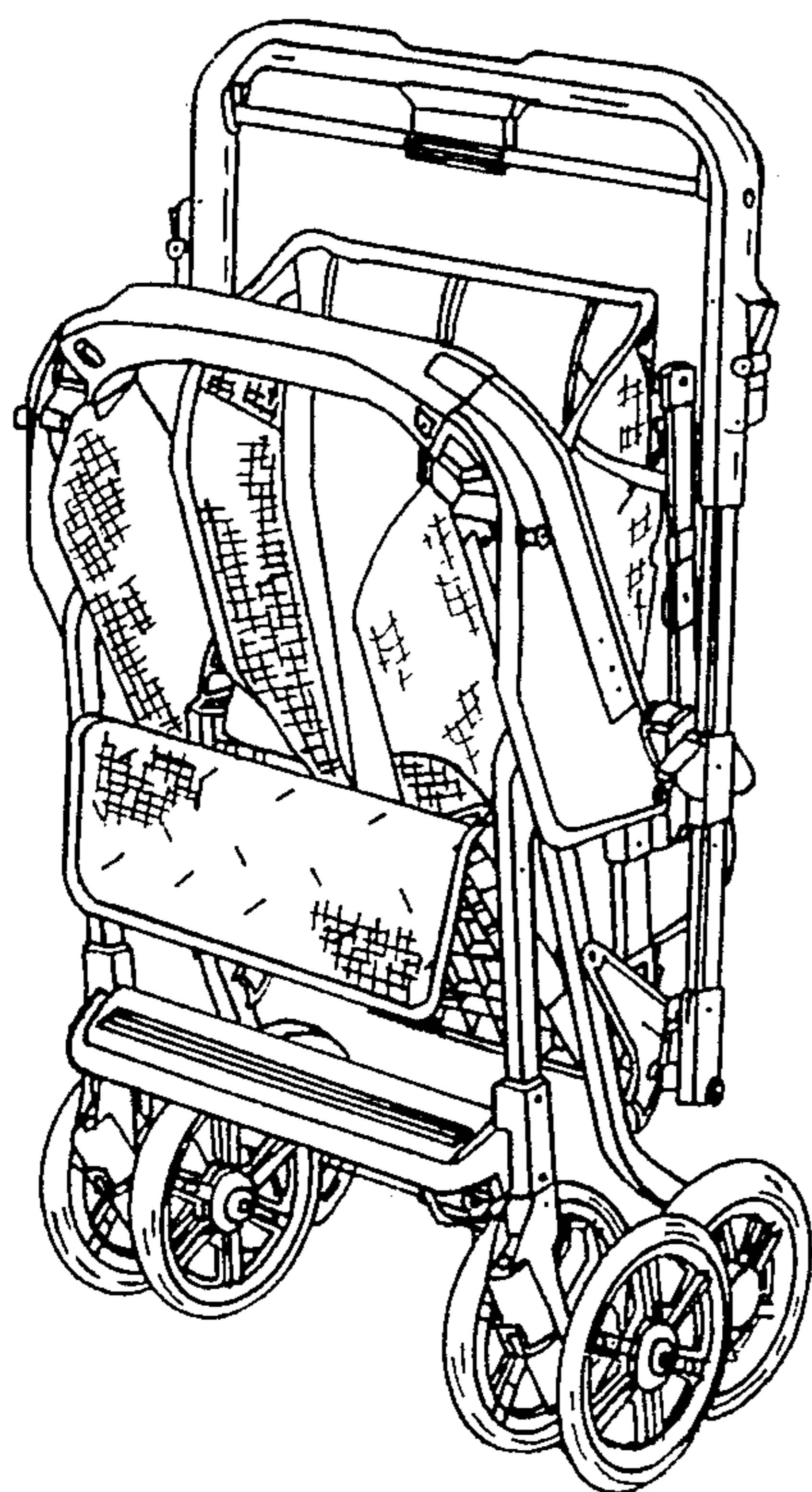

FIG. 26