

[54] SHIP'S FUNNEL

[75] Inventor: Joseph Farcus, Biscayne Park, Fla.

[73] Assignee: Carnival Cruise Lines, Inc., Miami, Fla.

[**] Term: 14 Years

[21] Appl. No.: 859,893

[22] Filed: May 8, 1986

[52] U.S. Cl. D12/317; D12/345

[58] Field of Search D12/317, 345; 114/211, 114/187, 272

[56] References Cited

U.S. PATENT DOCUMENTS

- 4,269,135 5/1981 Labonia 114/272
- 4,706,593 11/1987 Vail, Jr. 114/211

OTHER PUBLICATIONS

Currents, Winter 1987-1988, p. 14, Ship Design "The Funnels of Farcus".

Yachting, Nov. 1949, pp. 37, 38, FIG. 9, Dorade type ventilator.

Primary Examiner—Wallace R. Burke
Assistant Examiner—Kay H. Chin
Attorney, Agent, or Firm—Thomas M. Freiburger

[57] CLAIM

The ornamental design for a ship's funnel, as shown and described.

DESCRIPTION

FIG. 1 is a rear perspective view of a ship's funnel showing my new design;
 FIG. 2 is a left side elevational view thereof, the right side elevational view being a mirror image of that shown;
 FIG. 3 is a top plan view thereof;
 FIG. 4 is a bottom plan view thereof;
 FIG. 5 is a front elevation view thereof.
 FIG. 6 is a rear elevation view thereof.
 FIG. 7 is a front perspective view thereof on reduced scale, the broken lines are for illustrative purposes only and form no part of the claimed design.

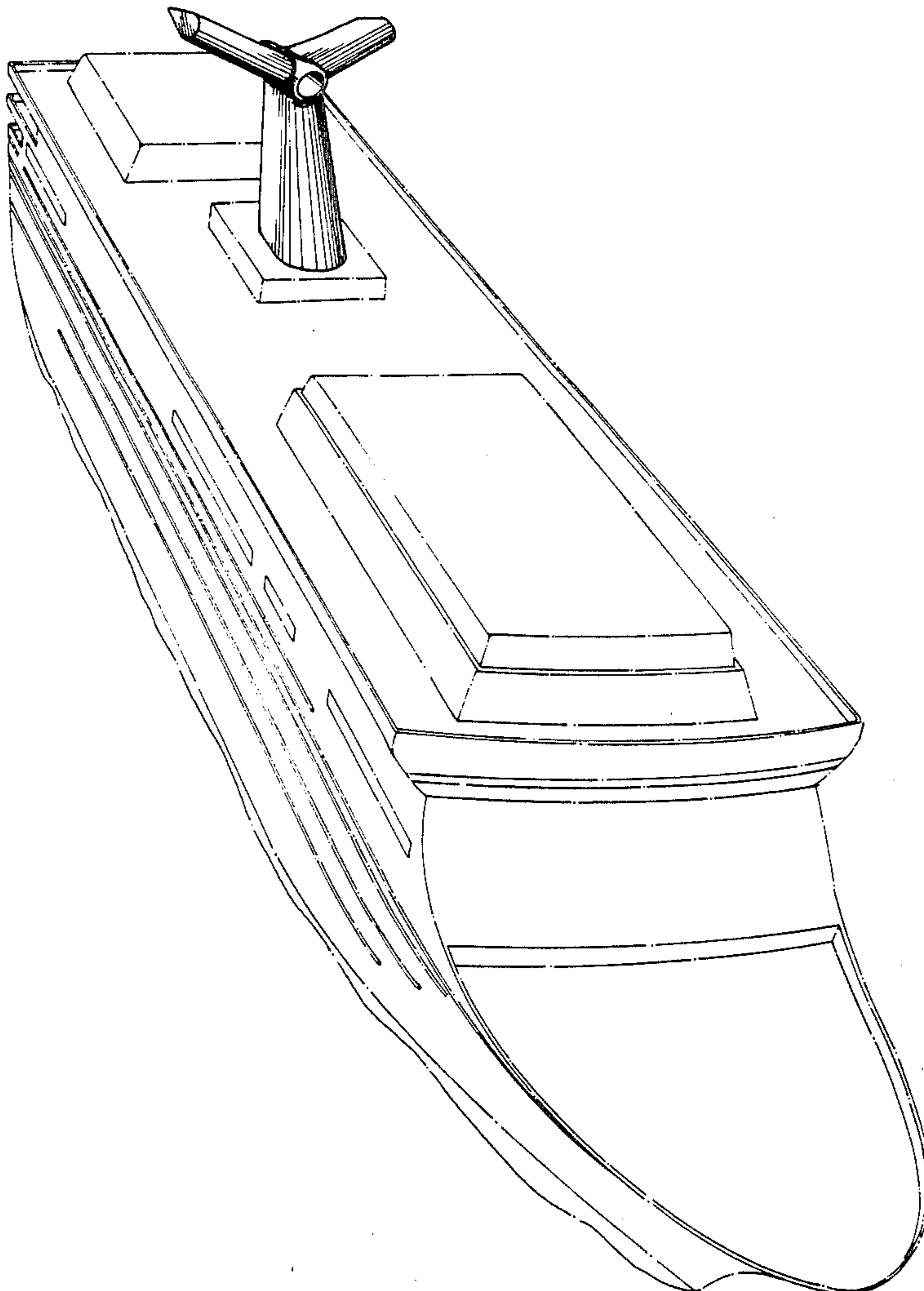

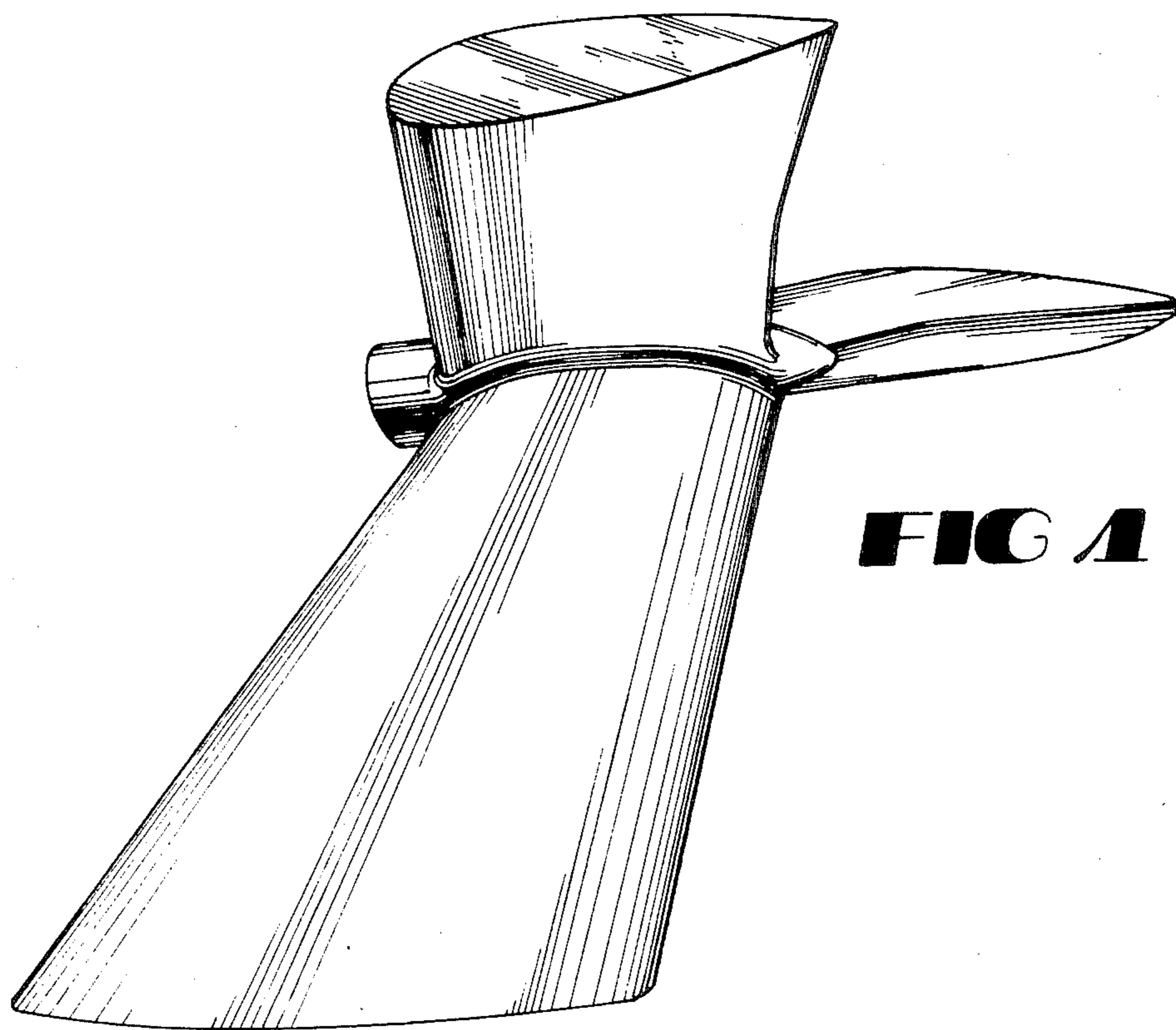

FIG 1

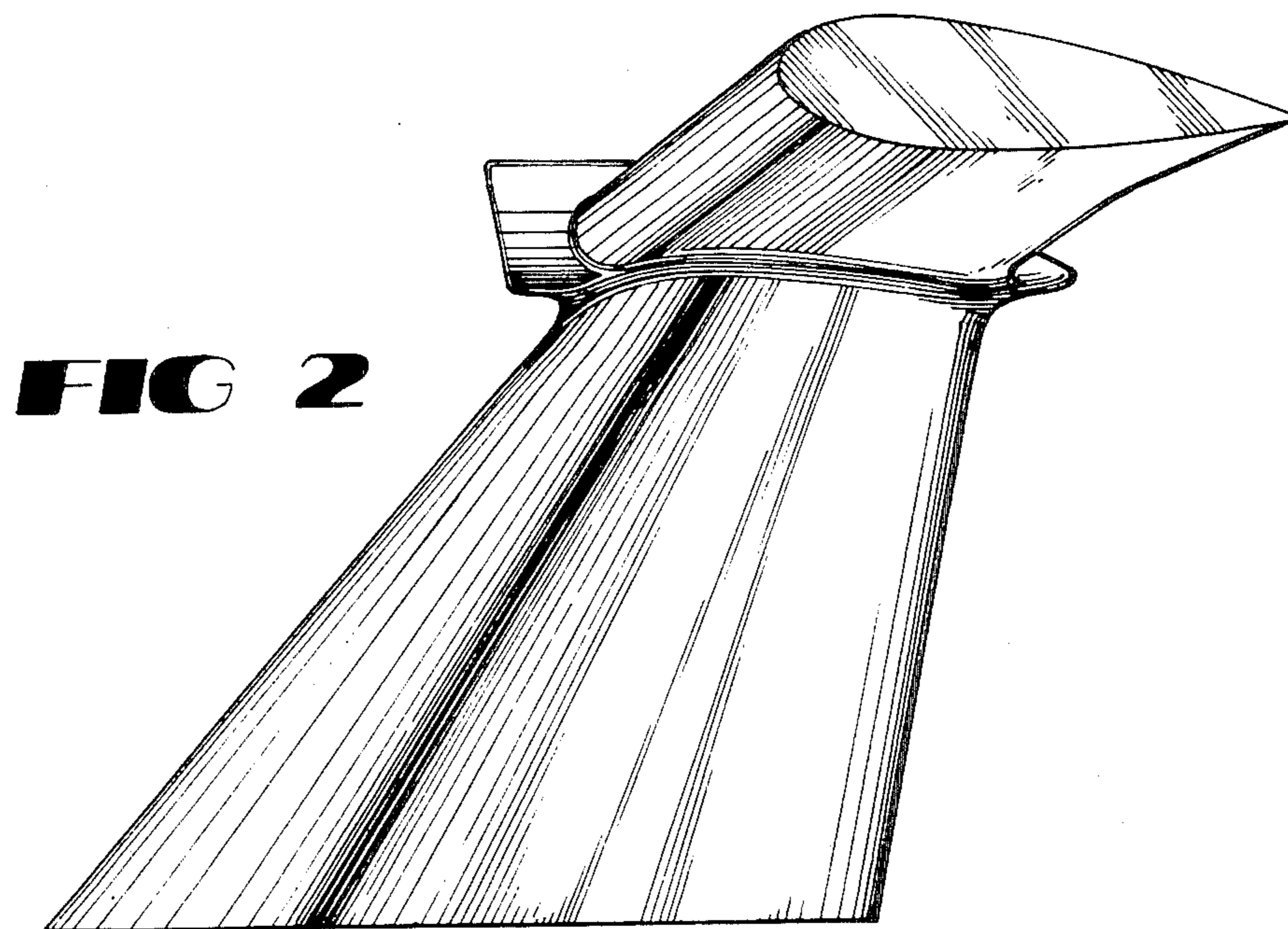

FIG 2

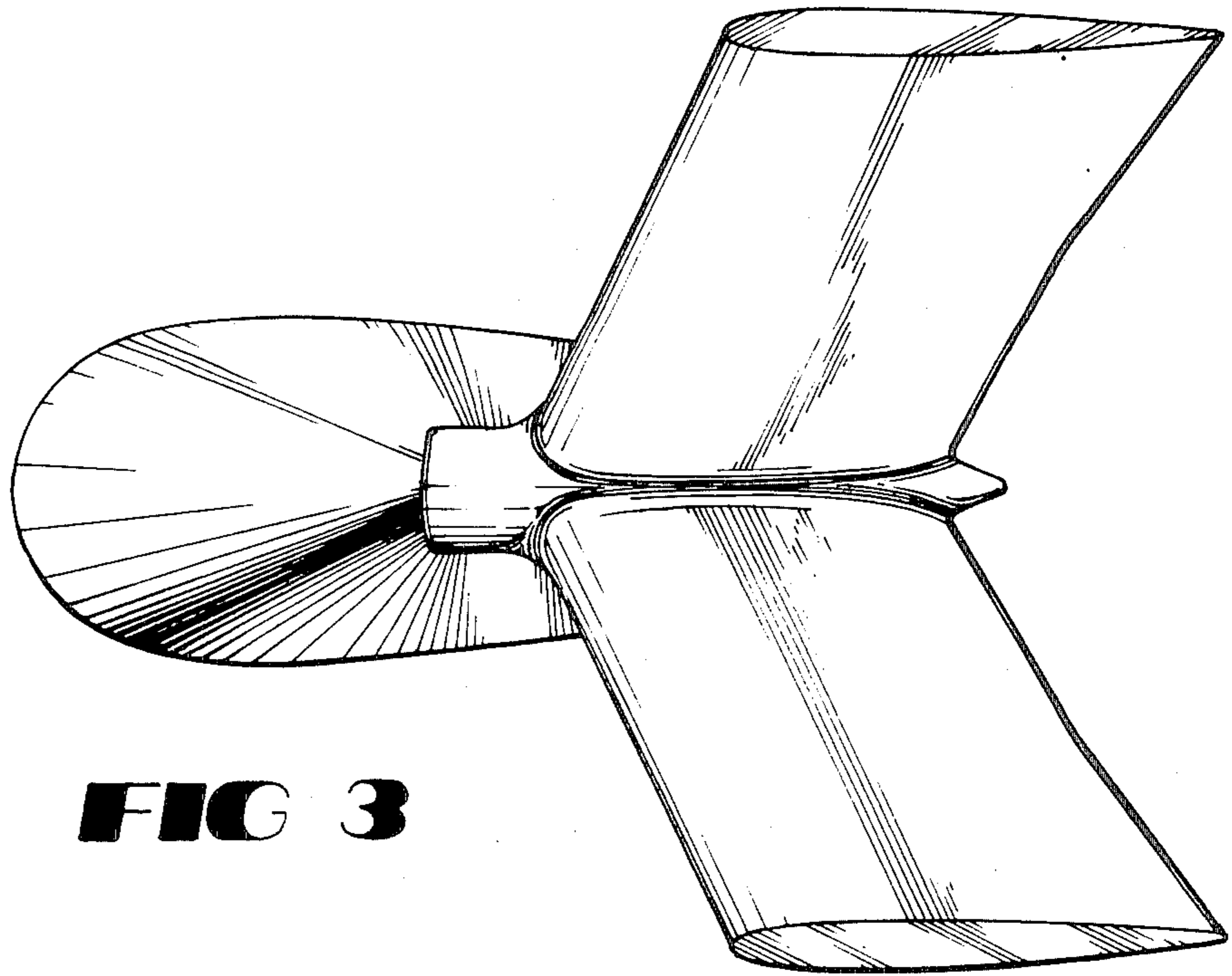

FIG 3

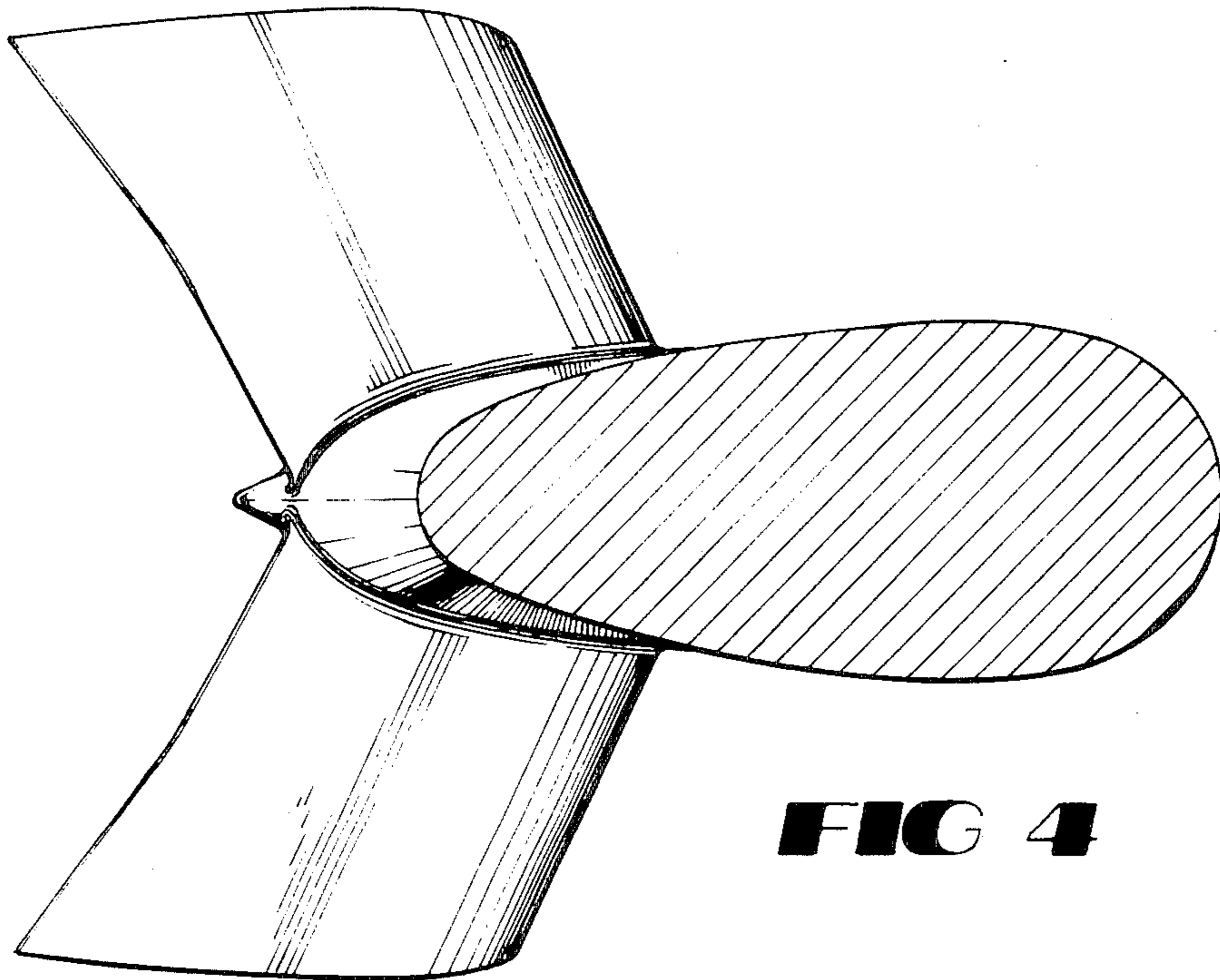

FIG 4

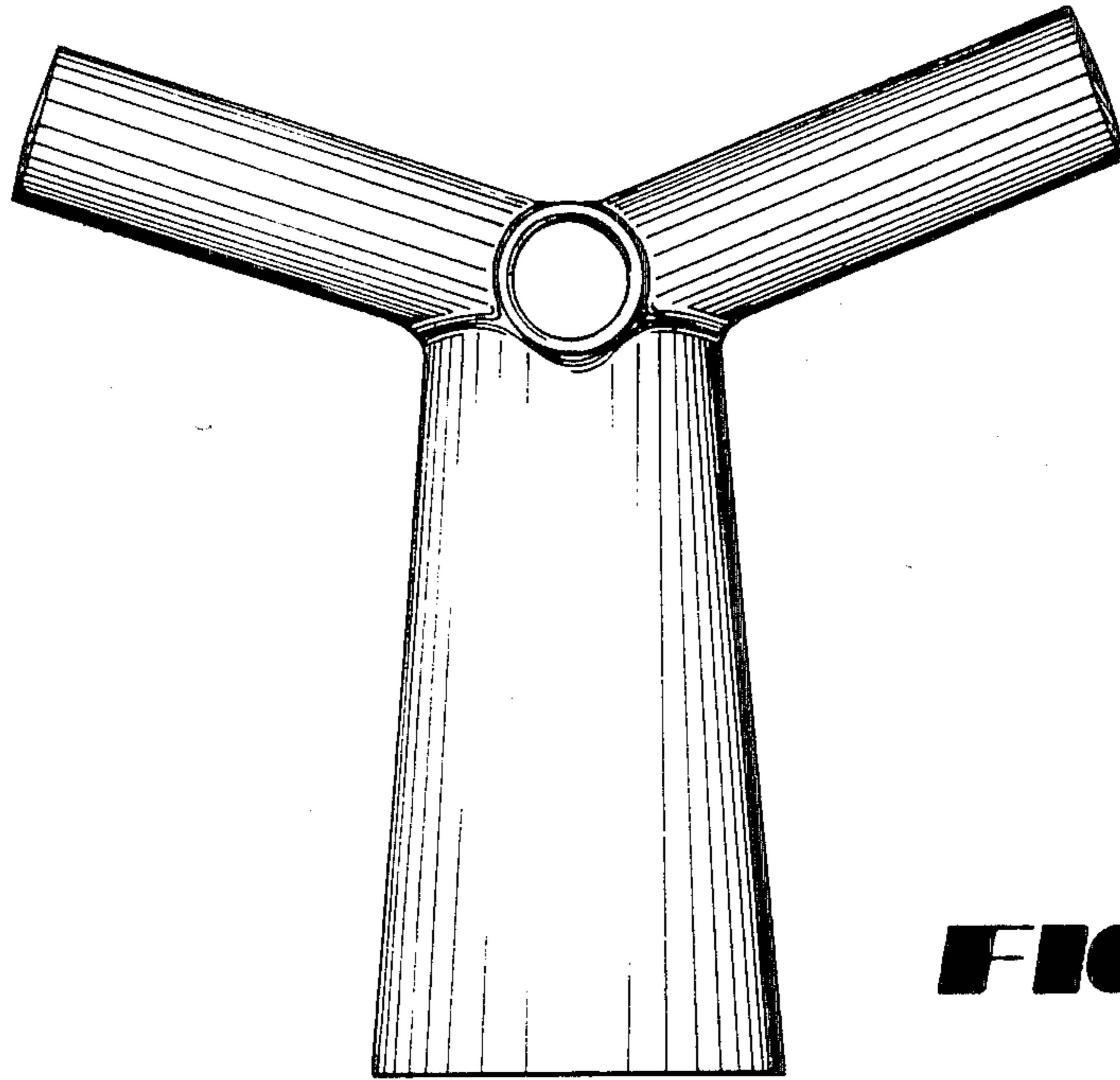

FIG 5

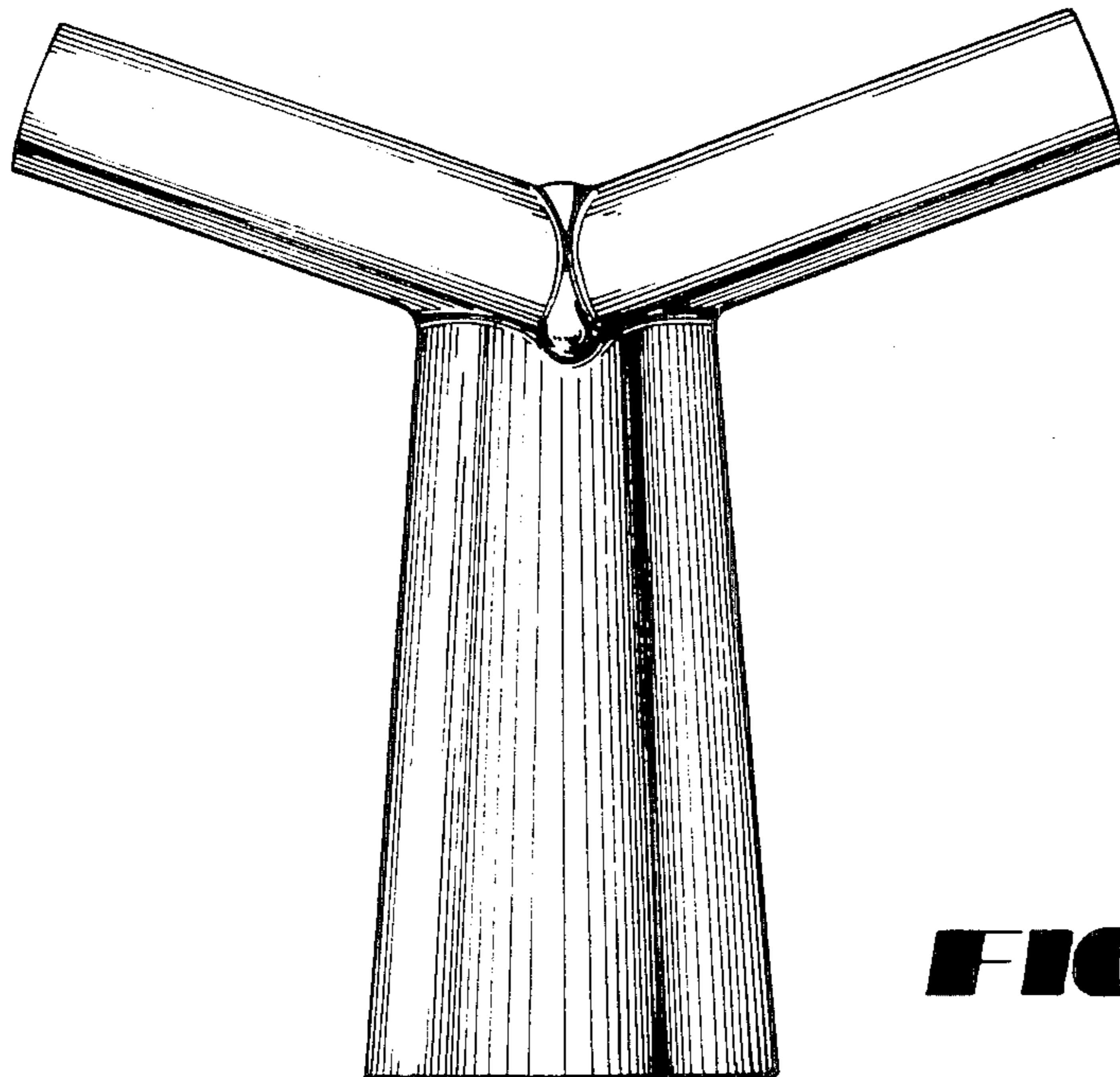

FIG 6

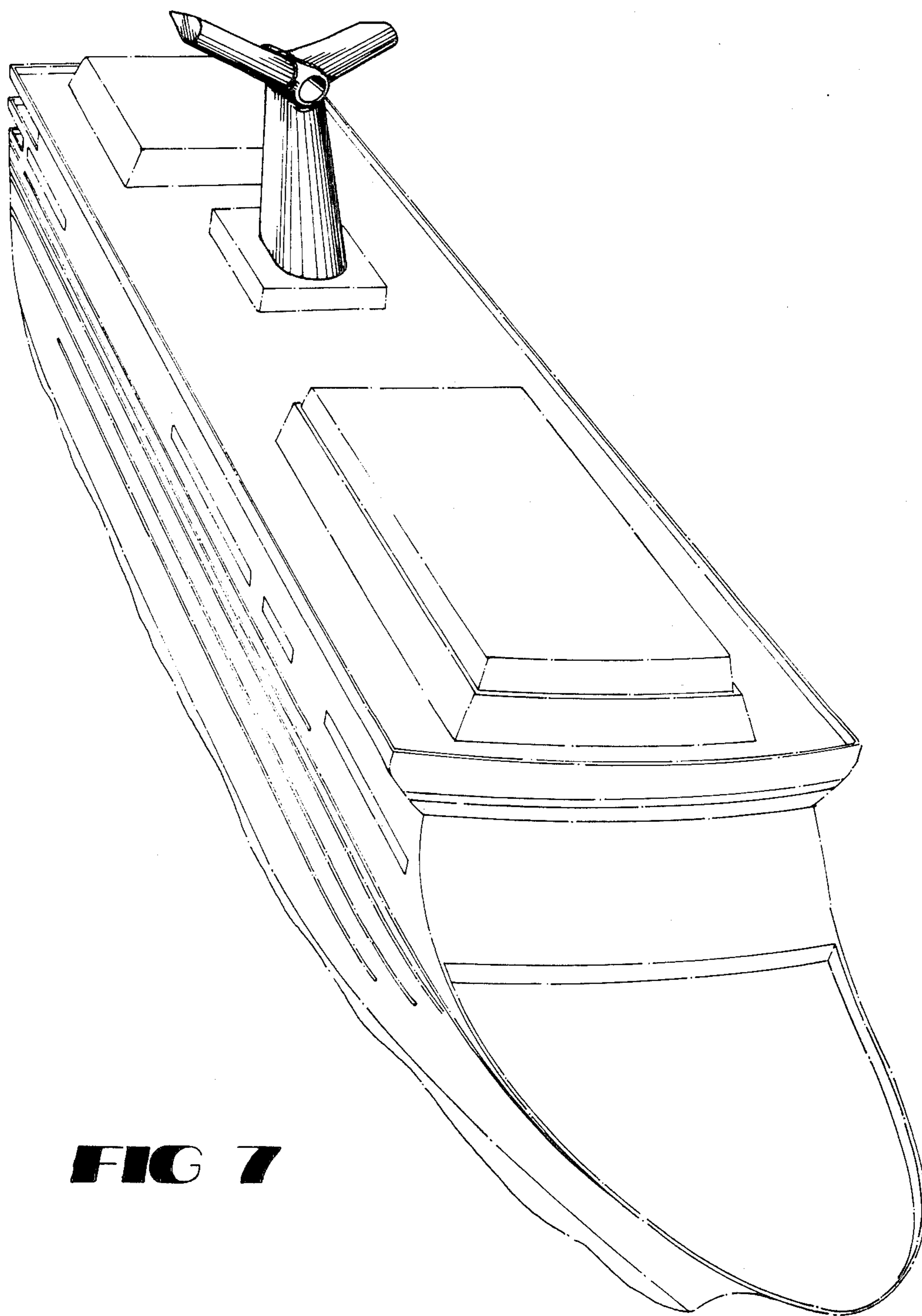

FIG 7