

[54] **HANGING MODULAR PLANTER**

[76] **Inventor: Norma E. Walsh, 922 S. Federal Hwy., B-3, Dania, Fla. 33004**

[**] **Term: 14 Years**

[21] **Appl. No.: 941,275**

[22] **Filed: Dec. 12, 1986**

[52] **U.S. Cl. D6/514**

[58] **Field of Search D6/403, 405, 513-514, D6/556, 558; 47/66-67; 108/59, 13, 71, 74, 113; 220/23.83; 248/27.8, 317-318**

[56] **References Cited**

U.S. PATENT DOCUMENTS

D. 232,282	8/1974	Wagschal	D6/514
D. 241,098	8/1976	Durfee	D6/513
D. 243,808	3/1977	Helm	D6/513
D. 247,838	5/1978	Jones et al.	D6/513
D. 253,505	11/1979	LeSage et al.	D6/513
D. 274,394	6/1984	Elliott	D6/403
925,799	6/1909	Boyd .	
982,350	1/1911	Cone .	
1,022,814	4/1912	Beehler .	
1,200,085	10/1916	Crane .	
1,441,264	1/1923	Bruewer .	
1,903,722	4/1933	Merritt .	
4,083,457	4/1978	Dromboski	211/71
4,561,208	12/1985	Schultz	47/39 X

Primary Examiner—Wallace R. Burke
Assistant Examiner—Brian N. Vinson
Attorney, Agent, or Firm—Dowell & Dowell

[57] **CLAIM**

The ornamental design for a hanging modular planter, as shown and described.

DESCRIPTION

FIG. 1 is a bottom perspective view of a hanging modular planter showing my new design, the portions of the chain link being omitted for convenience of illustration; FIG. 2 is a side elevational view of the top tier thereof, the opposite side being identical in appearance and the other tiers being omitted for convenience of illustration; FIG. 3 is a front elevational view of the top tier thereof, the rear being identical in appearance; FIG. 4 is a bottom plan view of the top tier thereof; FIG. 5 is a side elevational view of the second tier thereof, the opposite side being identical in appearance and the other tiers being omitted for convenience of illustration; FIG. 6 is a front elevational view of the second tier thereof, the rear being identical in appearance; FIG. 7 is a bottom plan view of the second tier thereof; FIG. 8 is a side elevational view of the third tier thereof, the opposite side being identical in appearance and the other tiers being omitted for convenience of illustration; FIG. 9 is a front elevational view of the third tier thereof, the rear being identical in appearance; FIG. 10 is a bottom plan view of the third tier thereof; FIG. 11 is a side elevational view of the bottom tier thereof, the opposite side being identical in appearance and the other tiers being omitted for convenience of illustration; FIG. 12 is a front elevational view of the bottom tier thereof, the rear being identical in appearance; and, FIG. 13 is a bottom plan view of the bottom tier thereof.

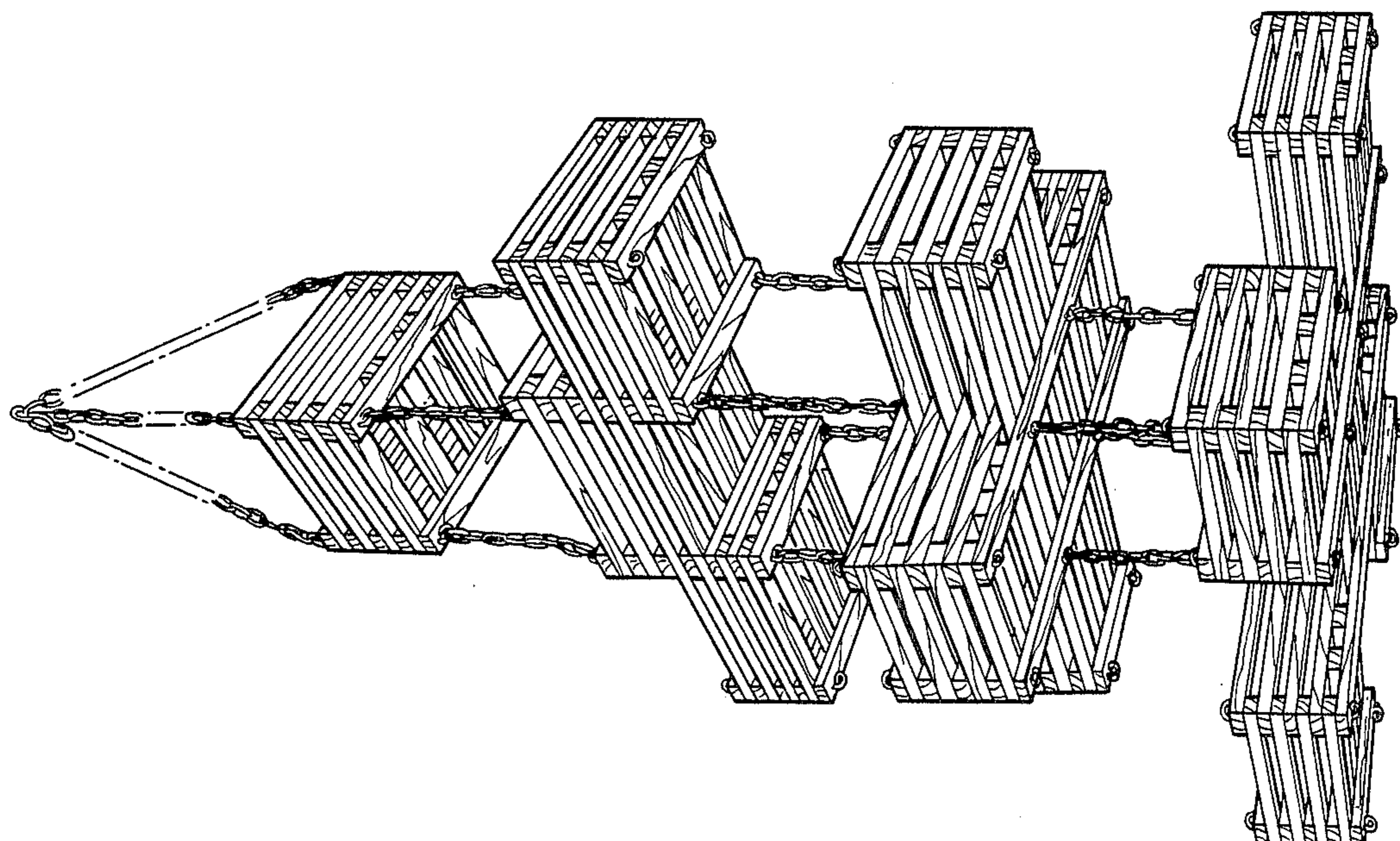

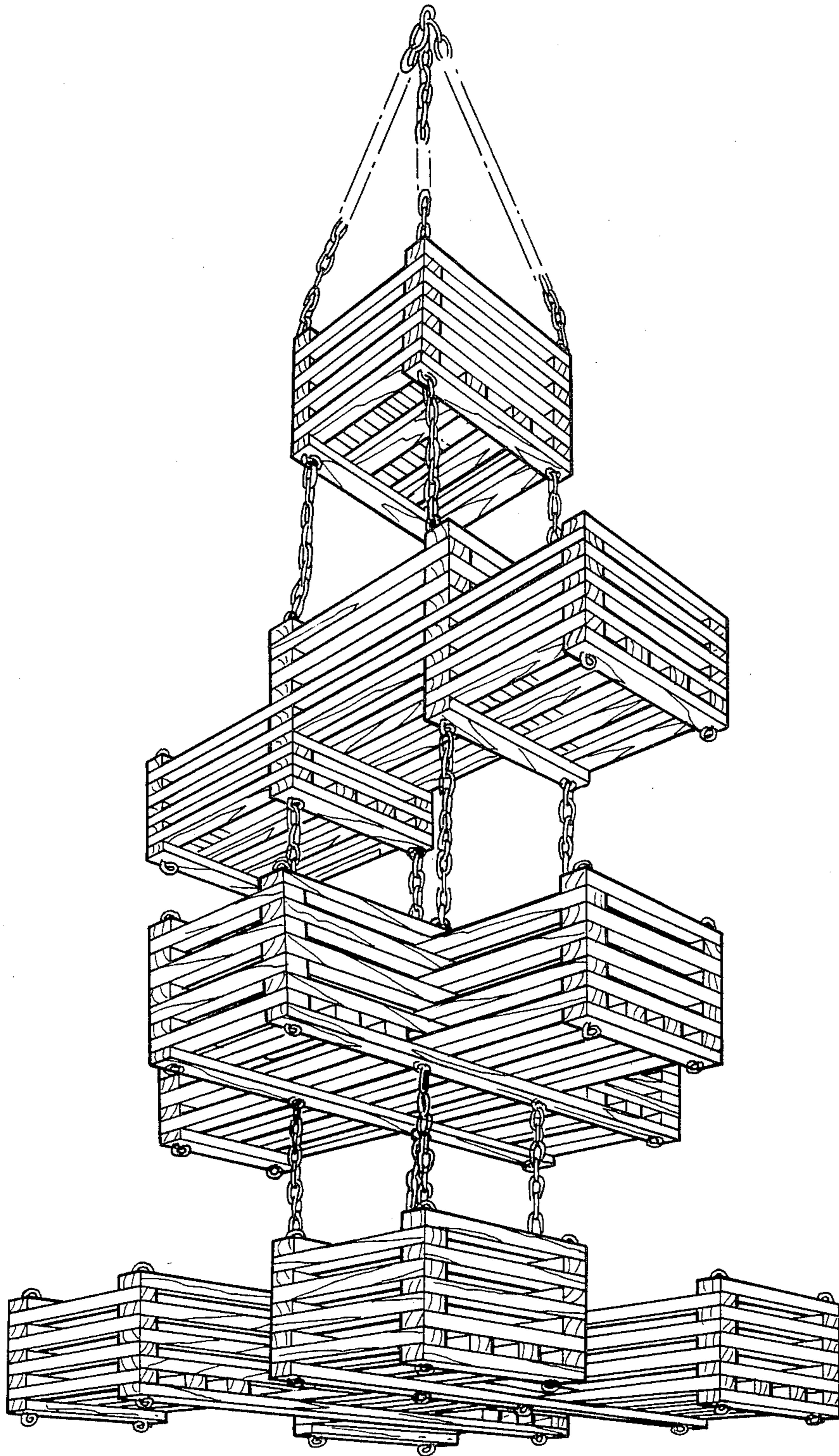

FIG. 1

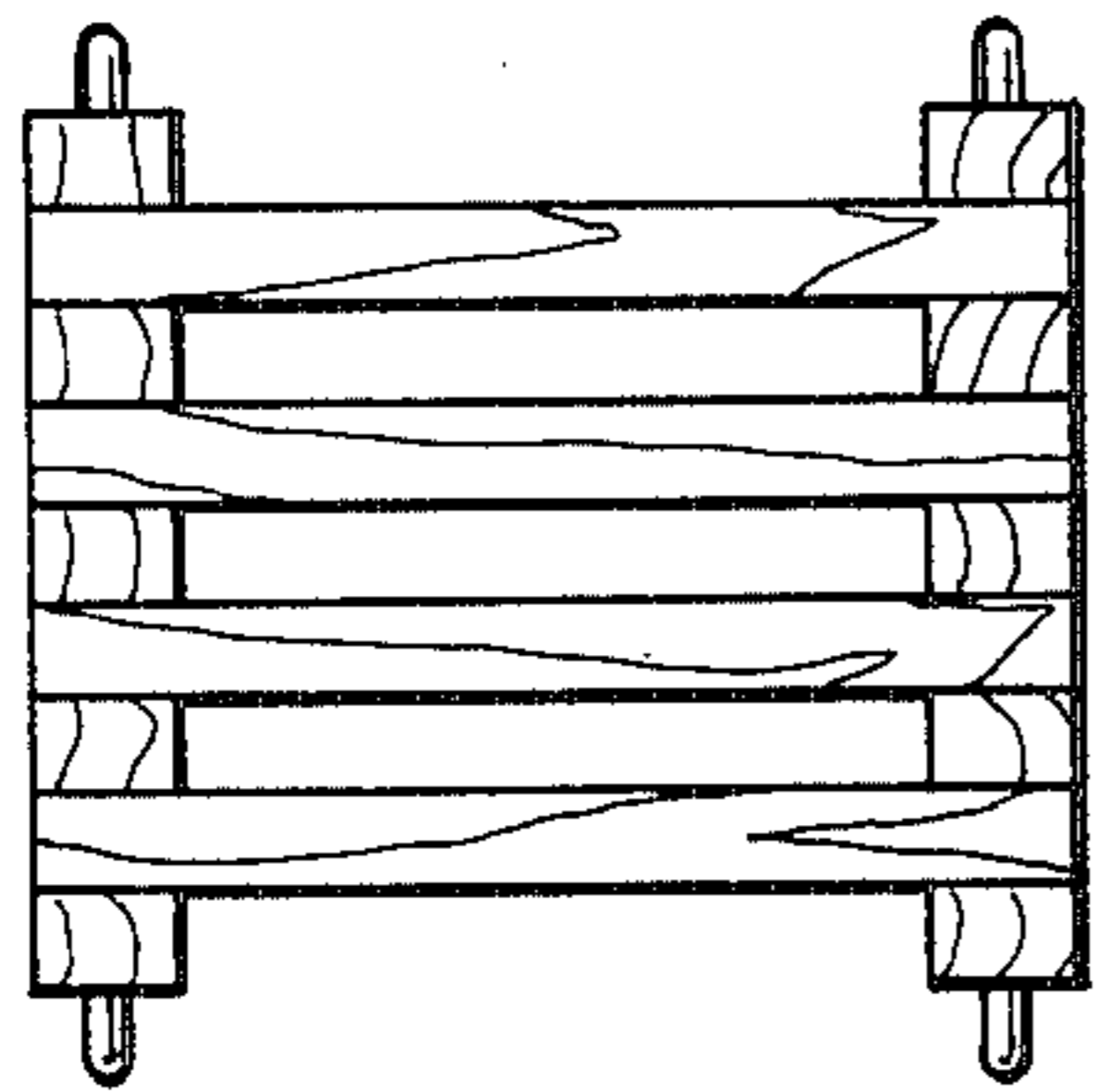

FIG. 2

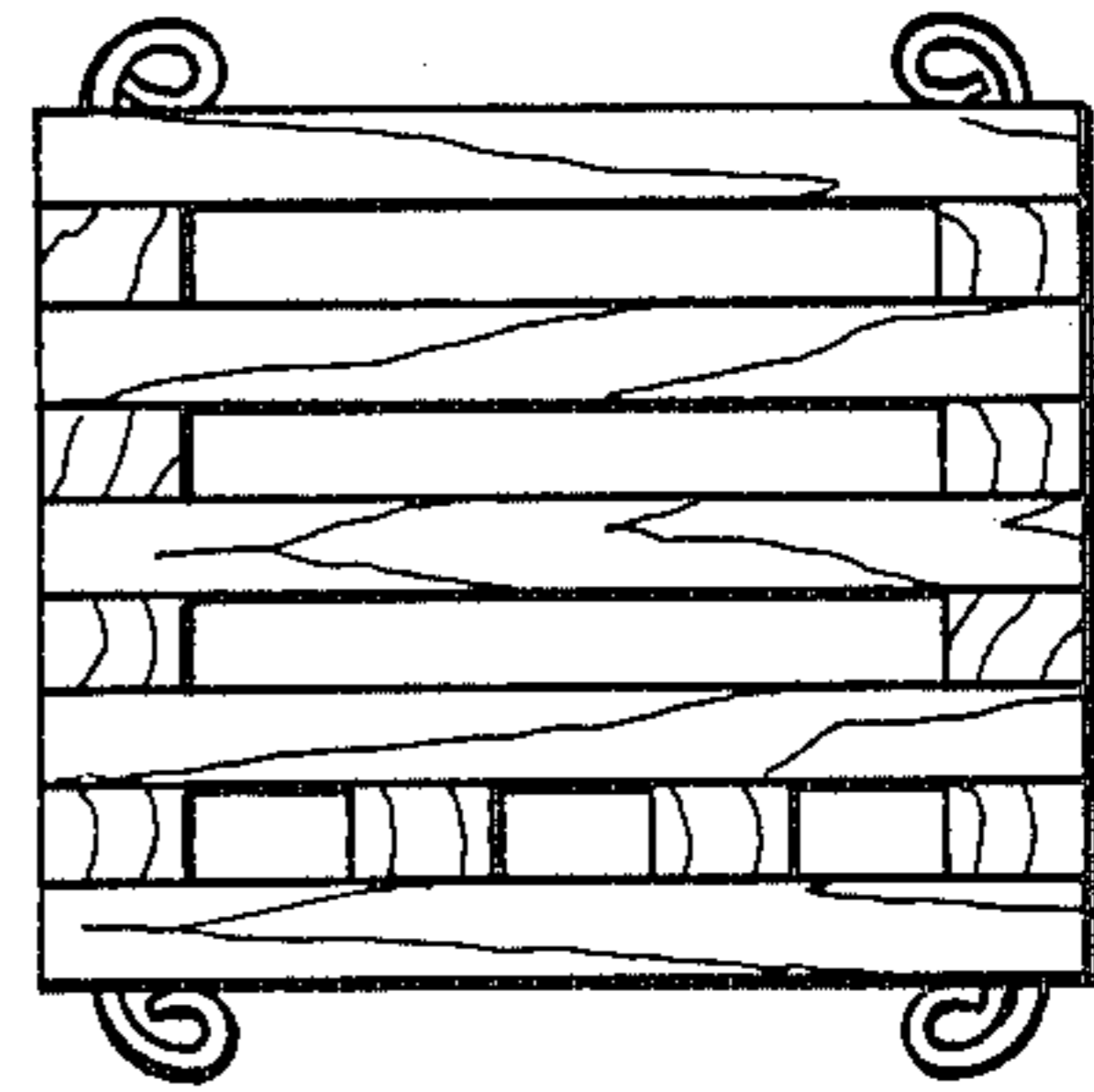

FIG. 3

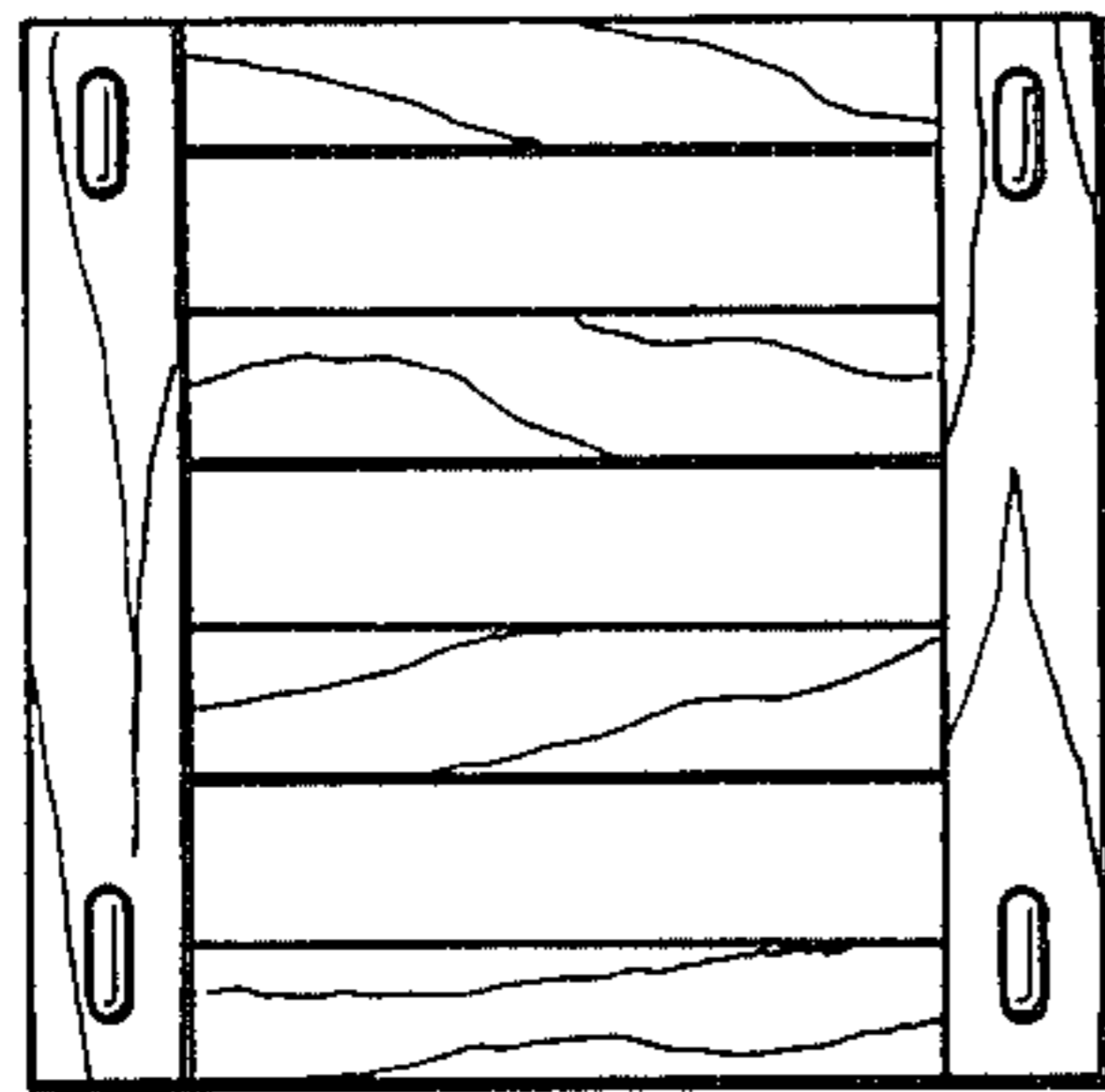

FIG. 4

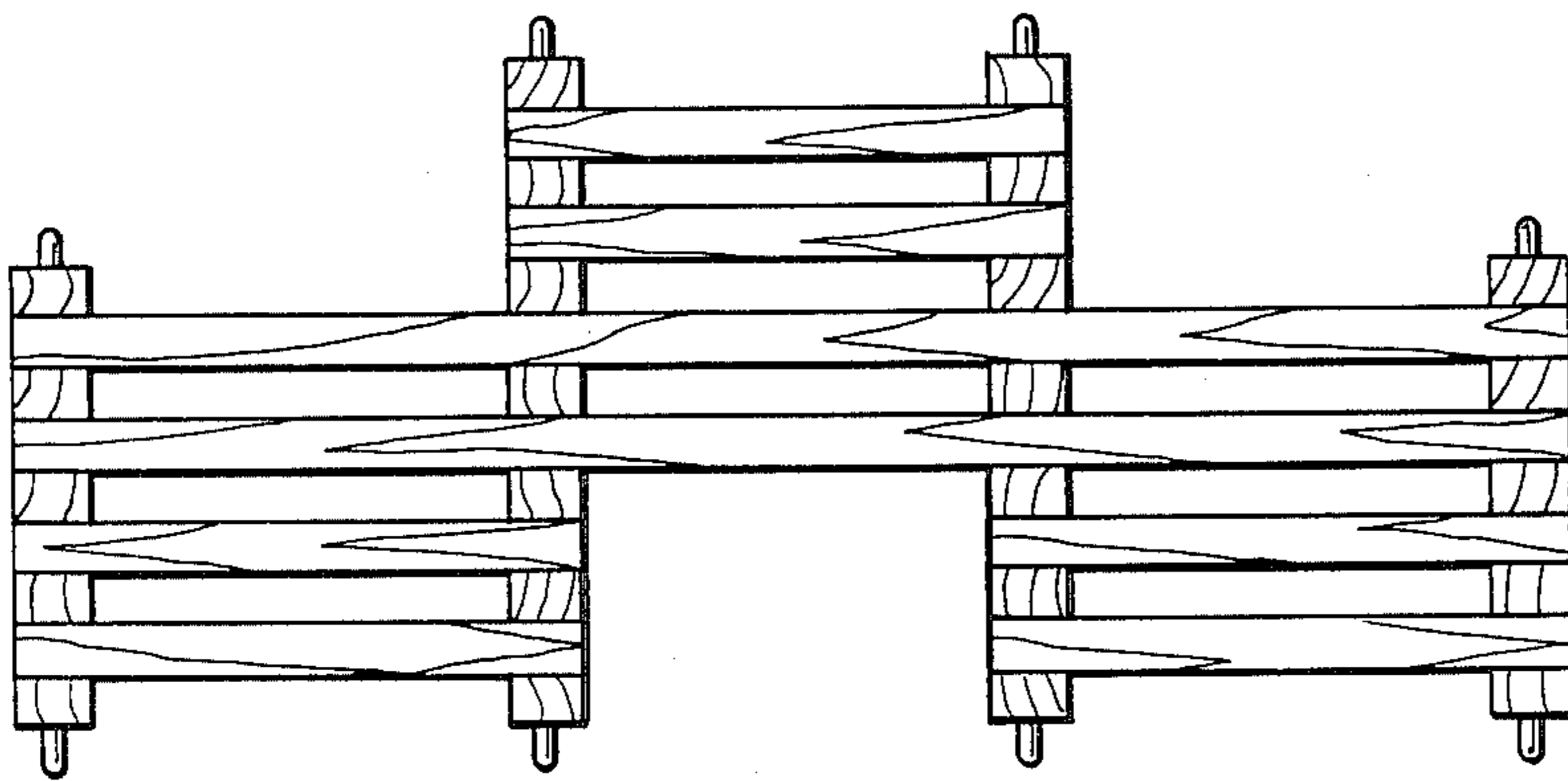

FIG. 5

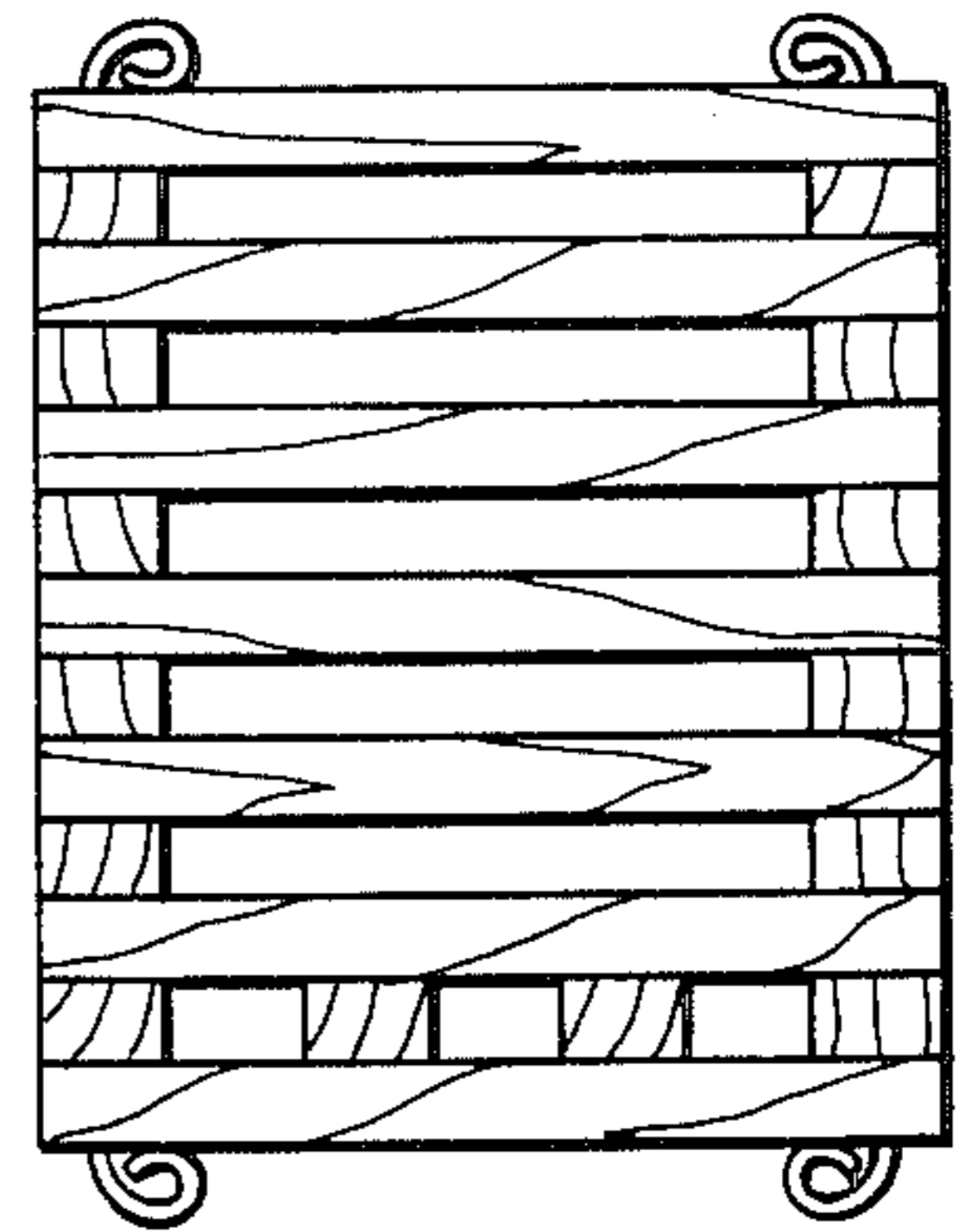

FIG. 6

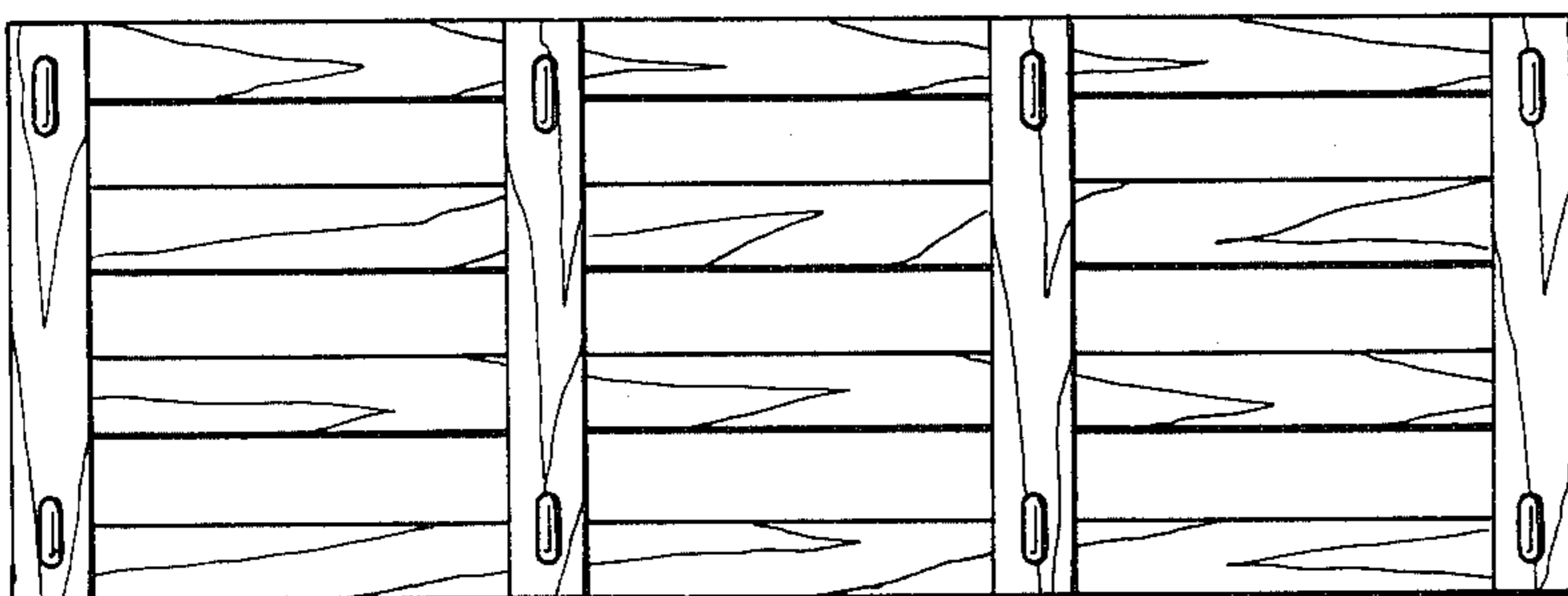

FIG. 7

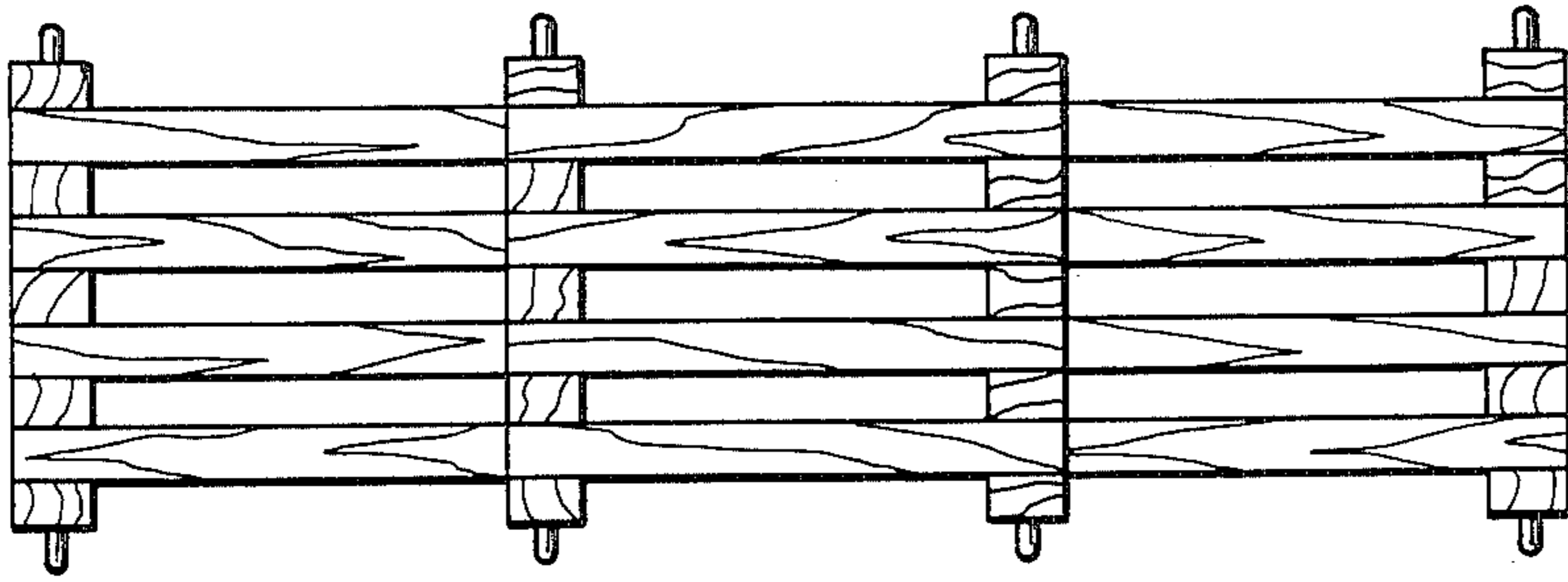

FIG. 8

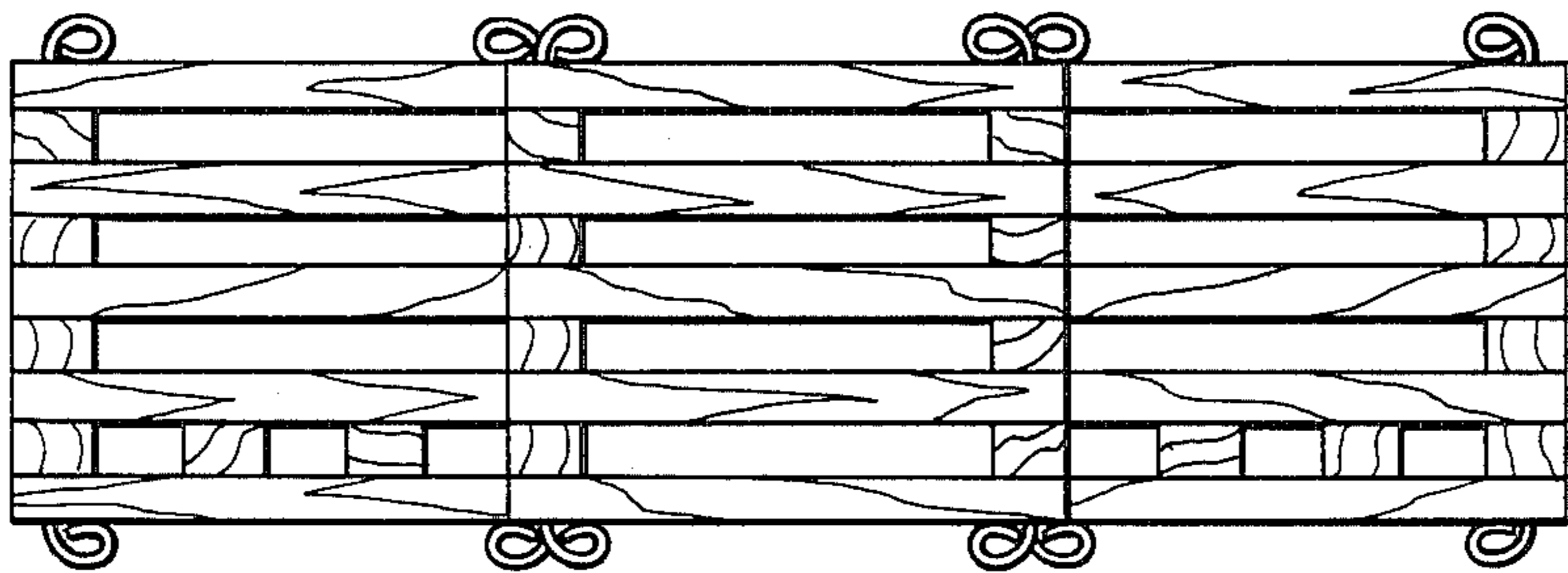

FIG. 9

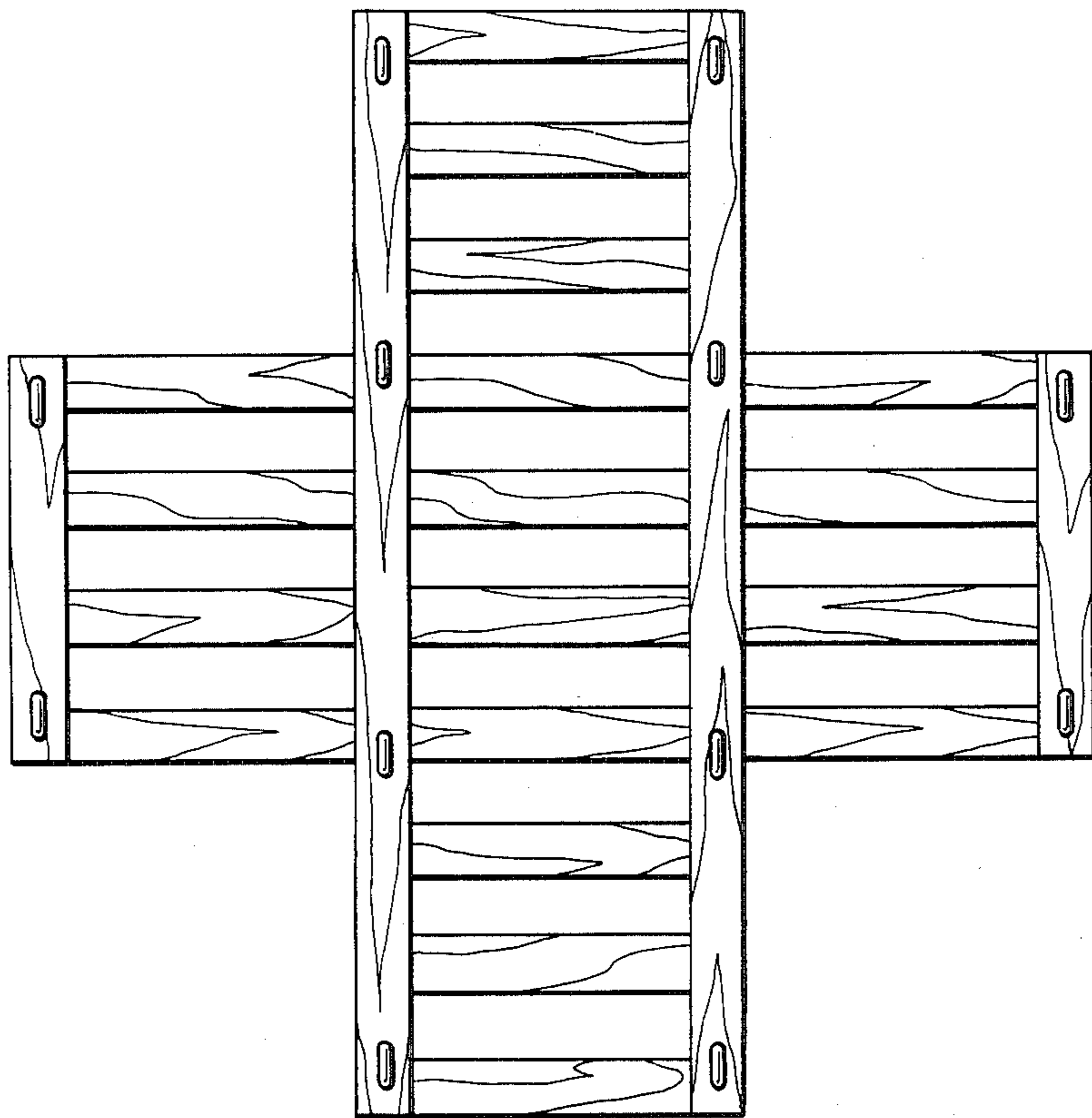

FIG. 10

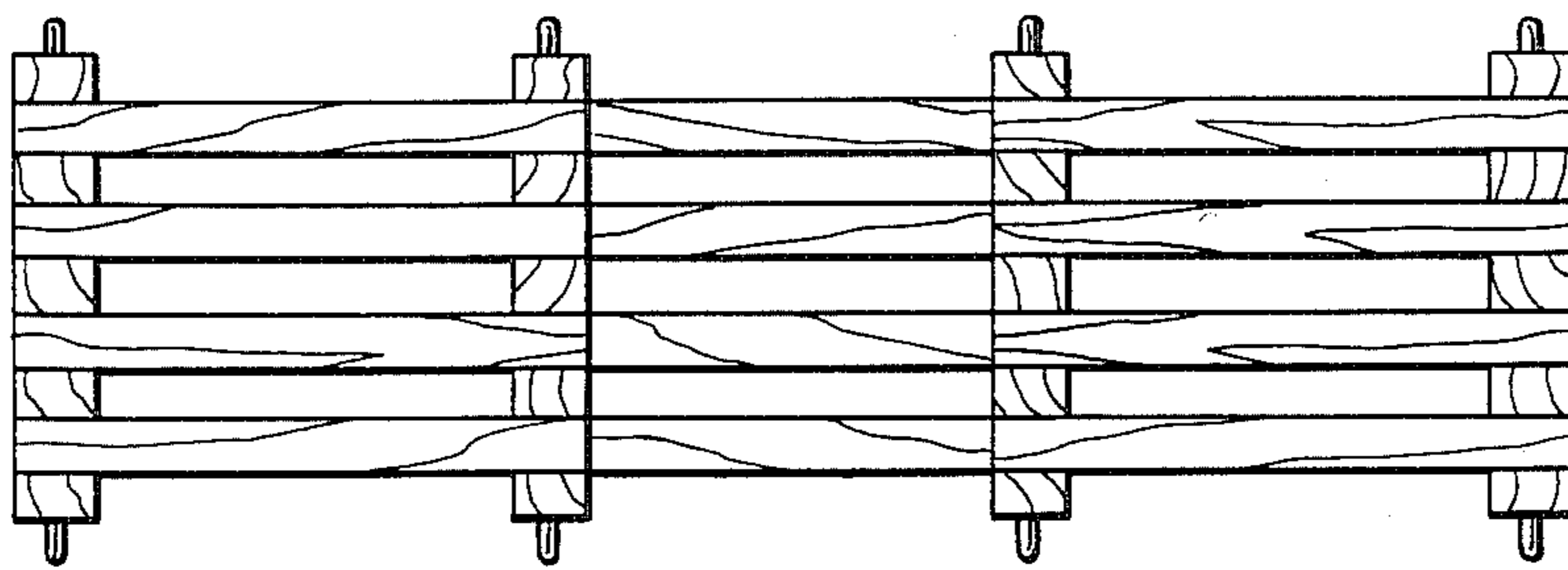

FIG. 11

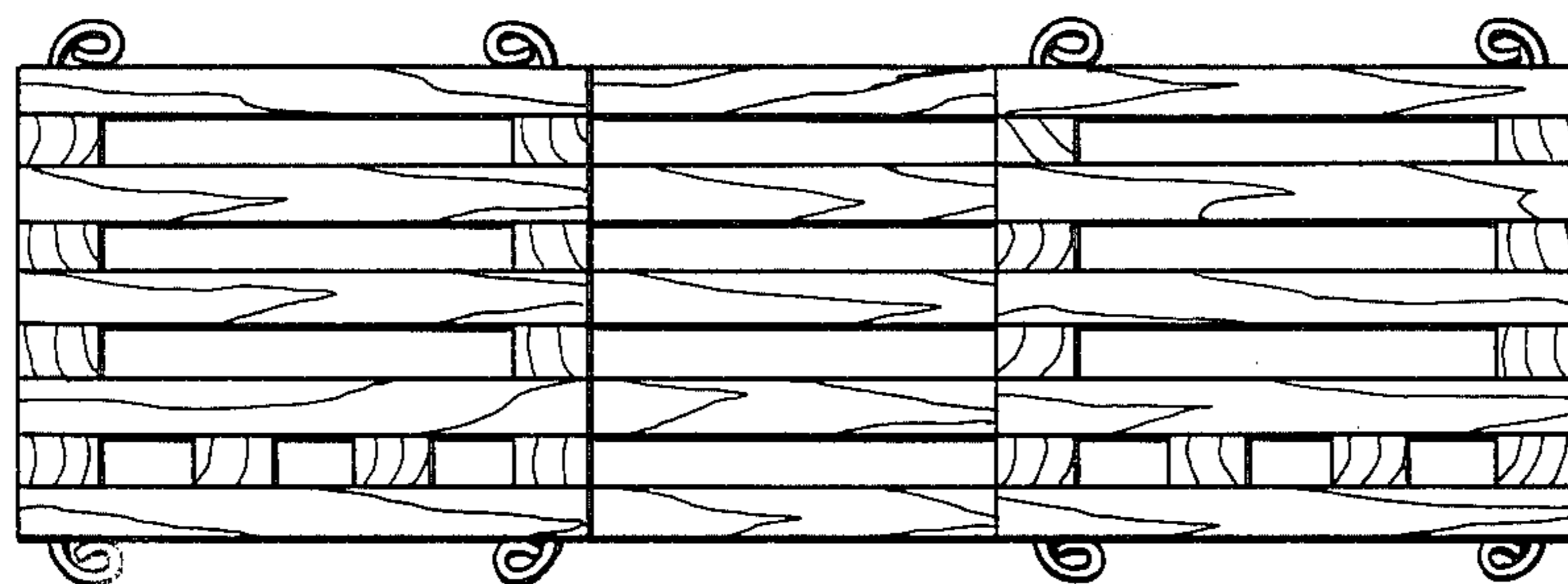

FIG. 12

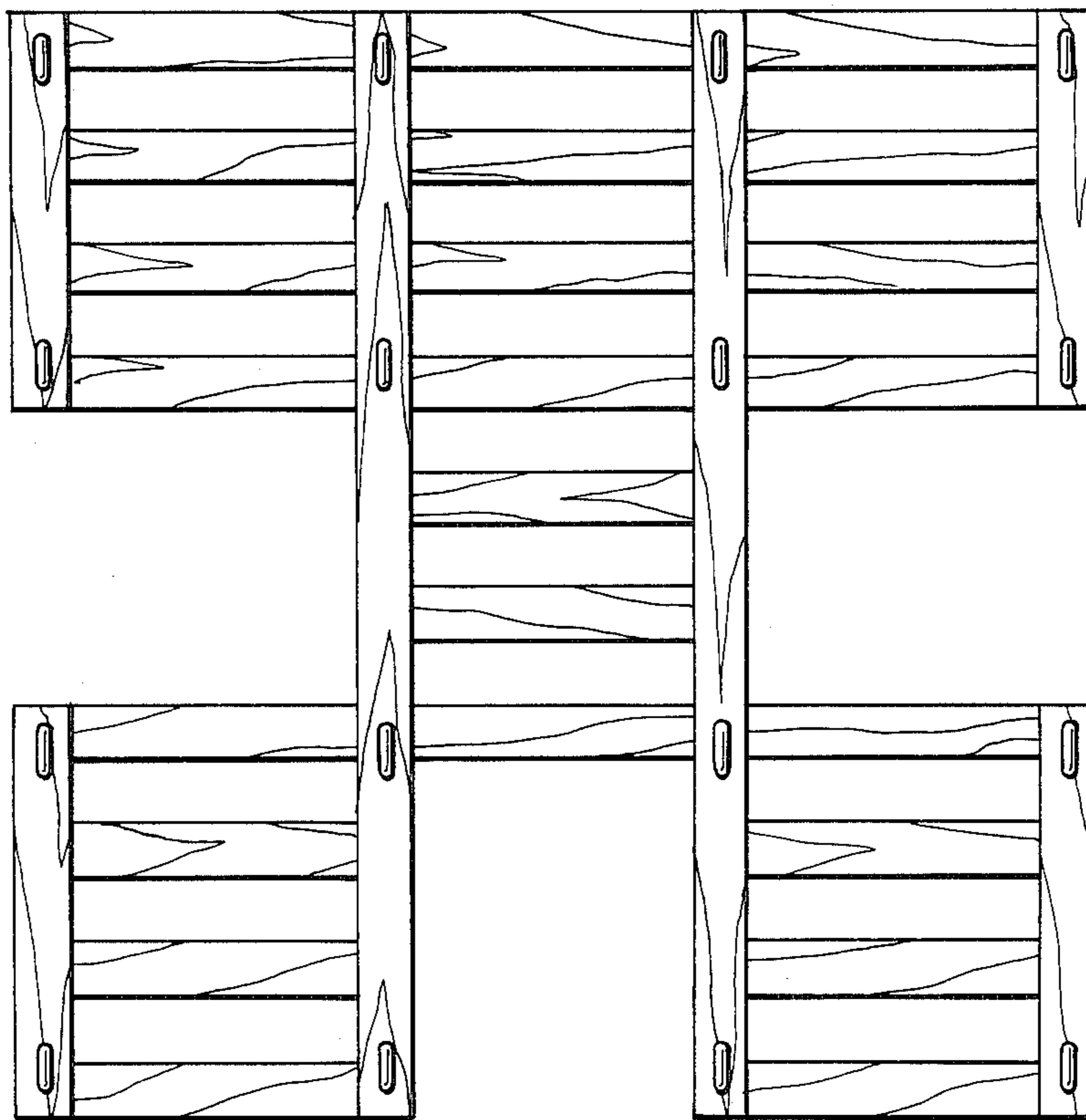

FIG. 13