

[54] FRONT PANEL FOR A BOAT CONSOLE OR SIMILAR ARTICLE

[75] Inventor: Peter J. Petrilli, Miami, Fla.

[73] Assignee: Mako Marine, Inc., Miami, Fla.

[\*\*] Term: 14 Years

[21] Appl. No.: 844,736

[22] Filed: Mar. 14, 1986

[52] U.S. Cl. .... D12/192; D12/317

[58] Field of Search ..... D12/192, 317, 318; 296/37.12, 70; 206/320; 114/343

[56] References Cited

U.S. PATENT DOCUMENTS

D. 260,755	9/1981	Shirley	.....	D12/317
4,447,860	5/1984	Stone et al.	.....	296/70
4,518,172	5/1985	Bortz et al.	.....	296/37.12
4,549,625	10/1985	Tindall	.....	296/70
4,706,810	11/1987	Petrilli	.....	114/343

FOREIGN PATENT DOCUMENTS

140280 8/1982 Japan ..... 296/37.12

Primary Examiner—Wallace R. Burke

Assistant Examiner—Kay H. Chin

Attorney, Agent, or Firm—Willian Brinks Olds Hofer Gilson & Lione

[57] CLAIM

The ornamental design for a front panel for a boat console or similar article, as shown and described.

DESCRIPTION

FIG. 1 is a front perspective view of a front panel for a boat console or similar article showing my new design; FIG. 2 is a top perspective view thereof;

FIG. 3 is a right side elevational view thereof, the left side elevational view being a mirror image of that shown; and

FIG. 4 is an enlarged front perspective view thereof with the glass doors thereon in partially raised condition.

The broken lines shown in FIGS. 3 and 4 of the drawing are for illustrative purposes only and form no part of the claimed design.

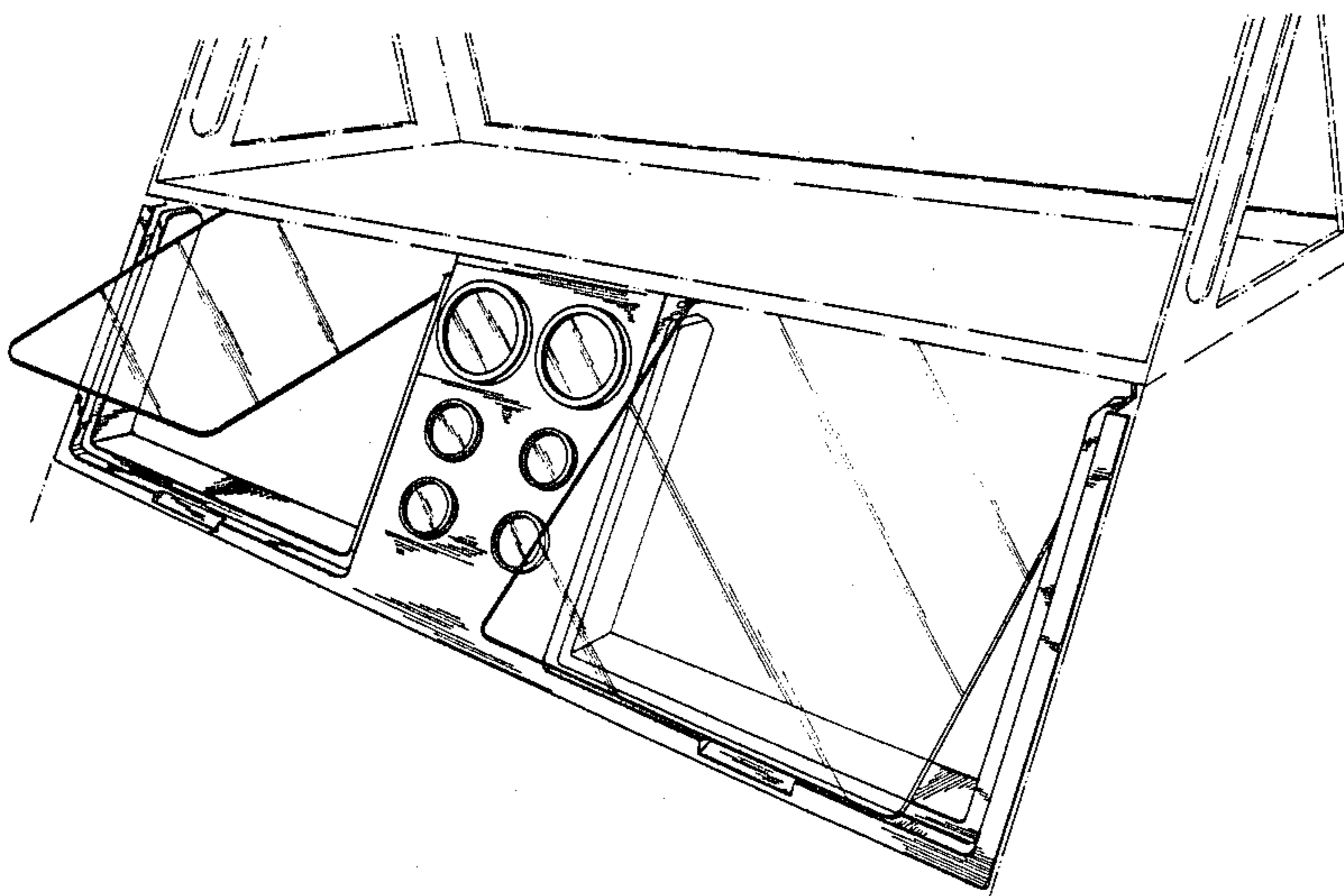

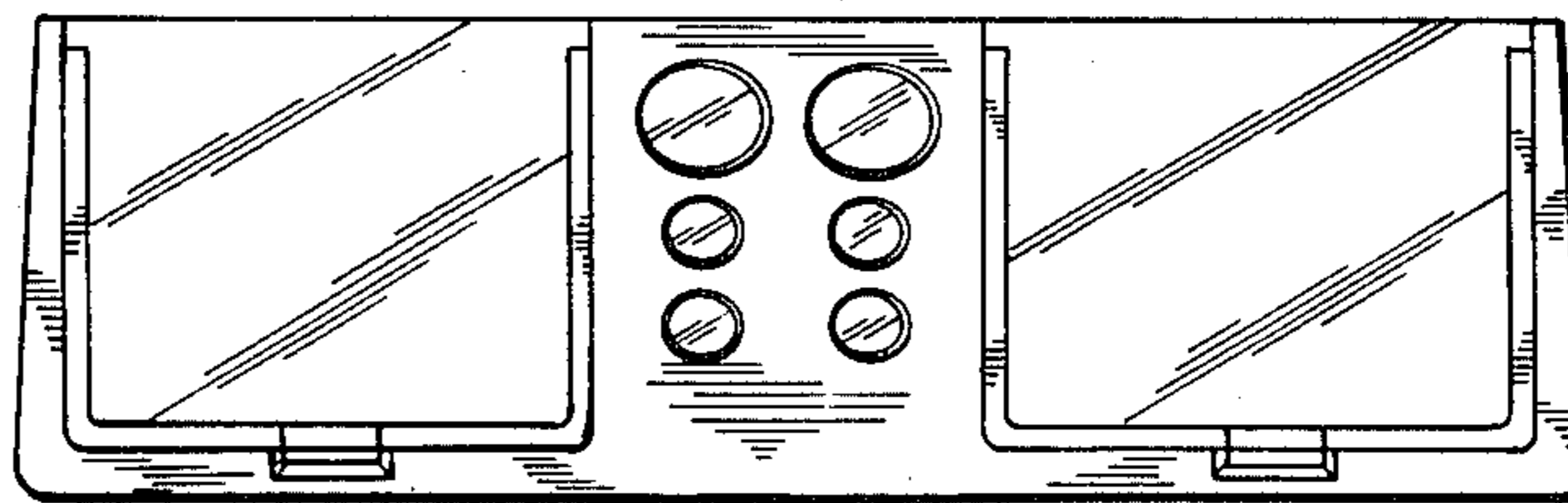

FIG. 1

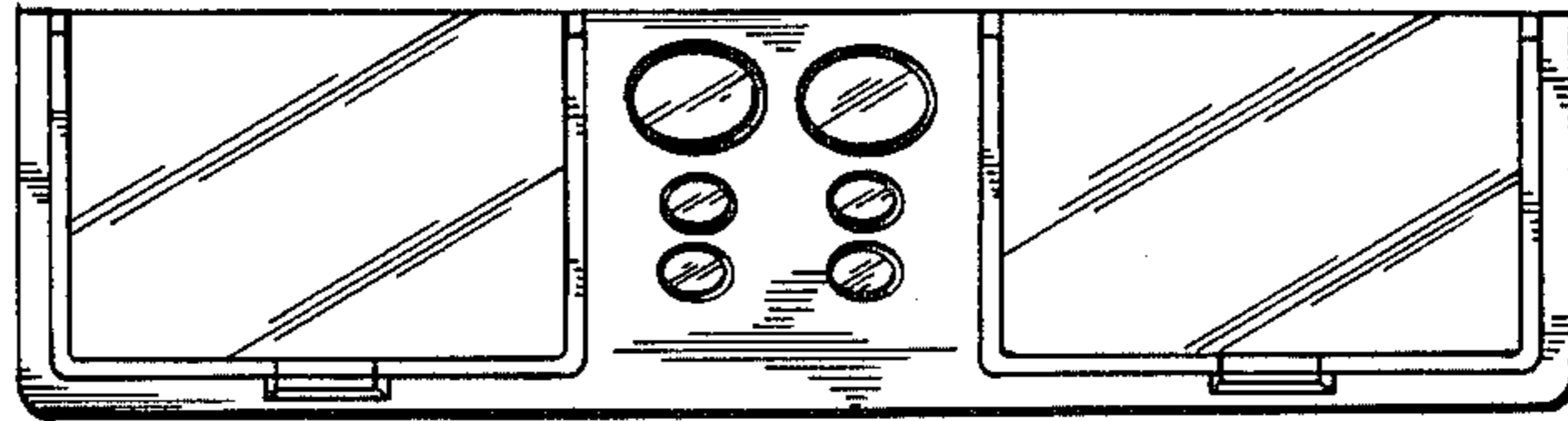
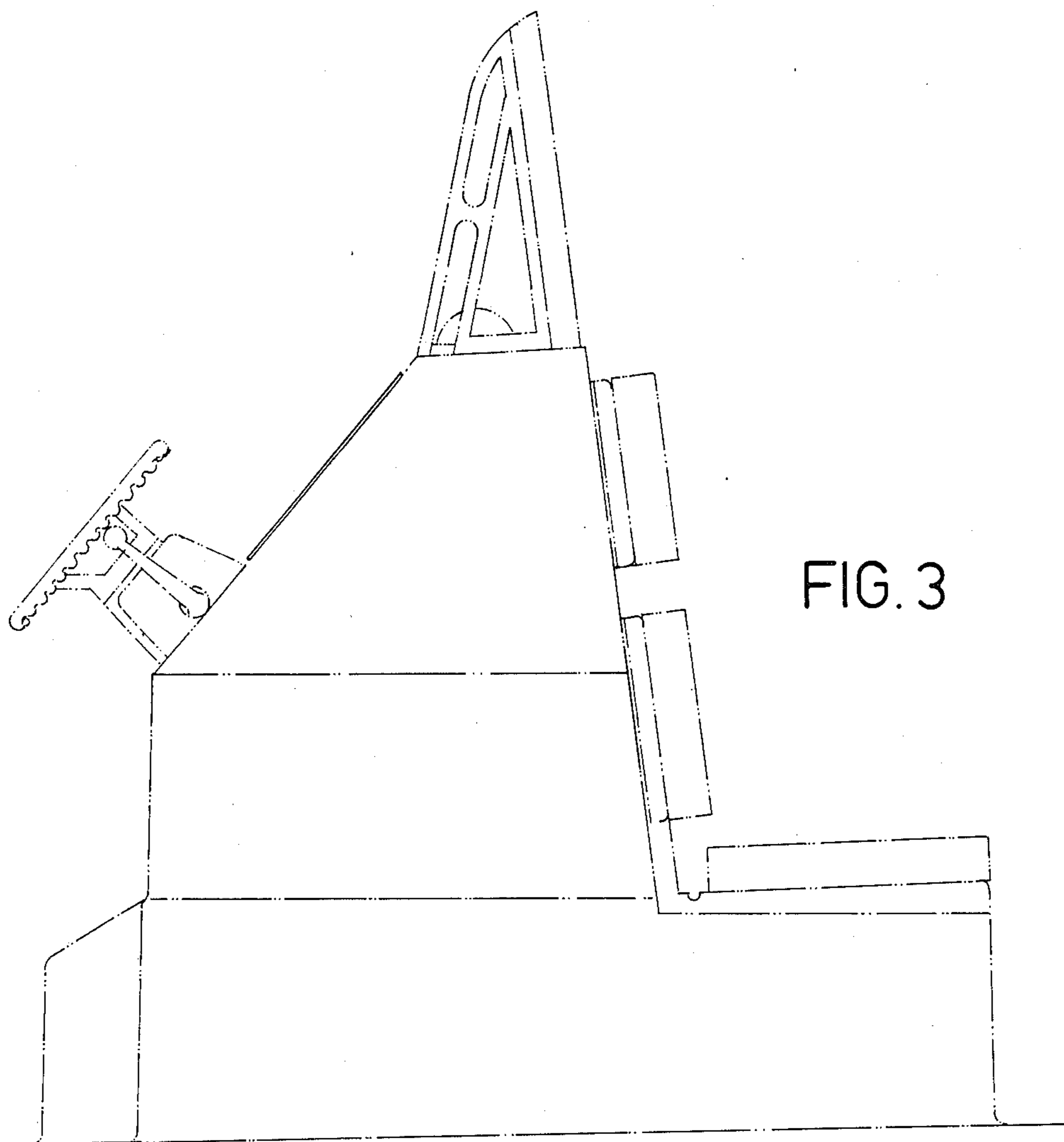

FIG. 2



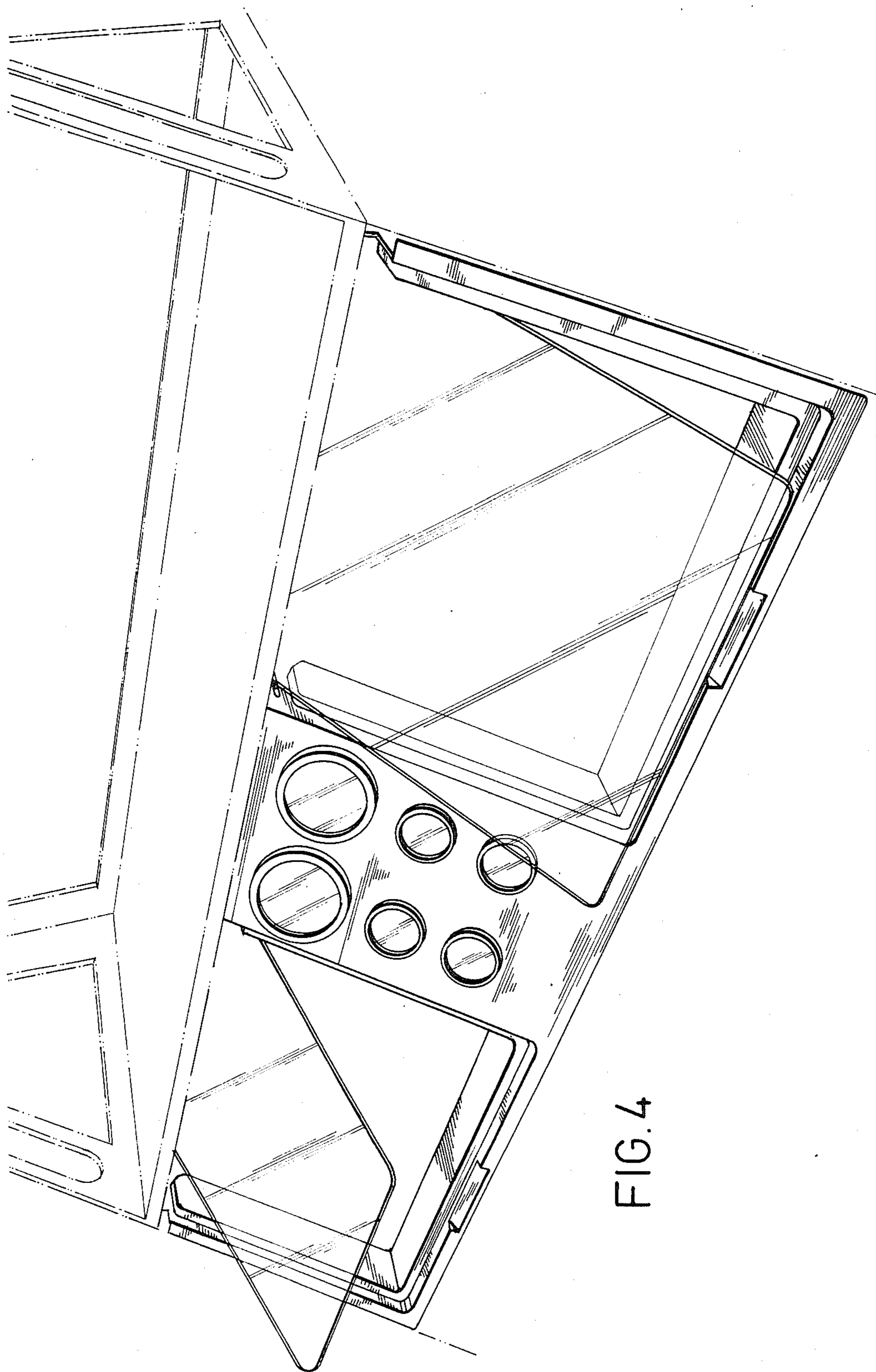

FIG. 4