

[54] COMBINED PICKUP TRUCK UTILITY BOX AND LEG SUPPORTS THEREFOR

[75] Inventor: Thomas Dickinson, St. Louis, Mo.

[73] Assignee: Contico Automotive, Inc., St. Louis, Mo.

[**] Term: 14 Years

[21] Appl. No.: 875,749

[22] Filed: Jun. 17, 1986

[52] U.S. Cl. D12/157

[58] Field of Search D12/157; 296/37.6; 224/42.11, 42.42

[56] References Cited

U.S. PATENT DOCUMENTS

- D. 257,340 10/1980 Grossman D12/157
- D. 271,009 10/1983 Fishler D12/157
- D. 285,673 9/1986 Waters D12/157

Primary Examiner—James M. Gandy
Attorney, Agent, or Firm—Kane, Dalsimer, Sullivan, Kurucz, Levy, Eisele and Richard

[57] CLAIM

The ornamental design for a combined pickup truck utility box and leg supports therefor, as shown and described.

DESCRIPTION

FIG. 1 is a front perspective view of a combined pickup truck utility box and leg supports therefor showing my new design it being understood that the broken lines are for illustrative purposes only and form no part of the claimed design;

FIG. 2 is an enlarged front elevation view thereof, it being understood that the rear is a mirror image of that shown;

FIG. 3 is a greatly enlarged fragmentary perspective view of the top and front thereof;

FIG. 4 is an enlarged right side elevation view thereof, the left side being a mirror image of that shown;

FIG. 5 is a greatly enlarged perspective view of one of the leg supports thereof shown separately for clarity of illustration; and

FIG. 6 is a greatly enlarged top, front and left side perspective view thereof with the leg supports omitted for convenience of illustration.

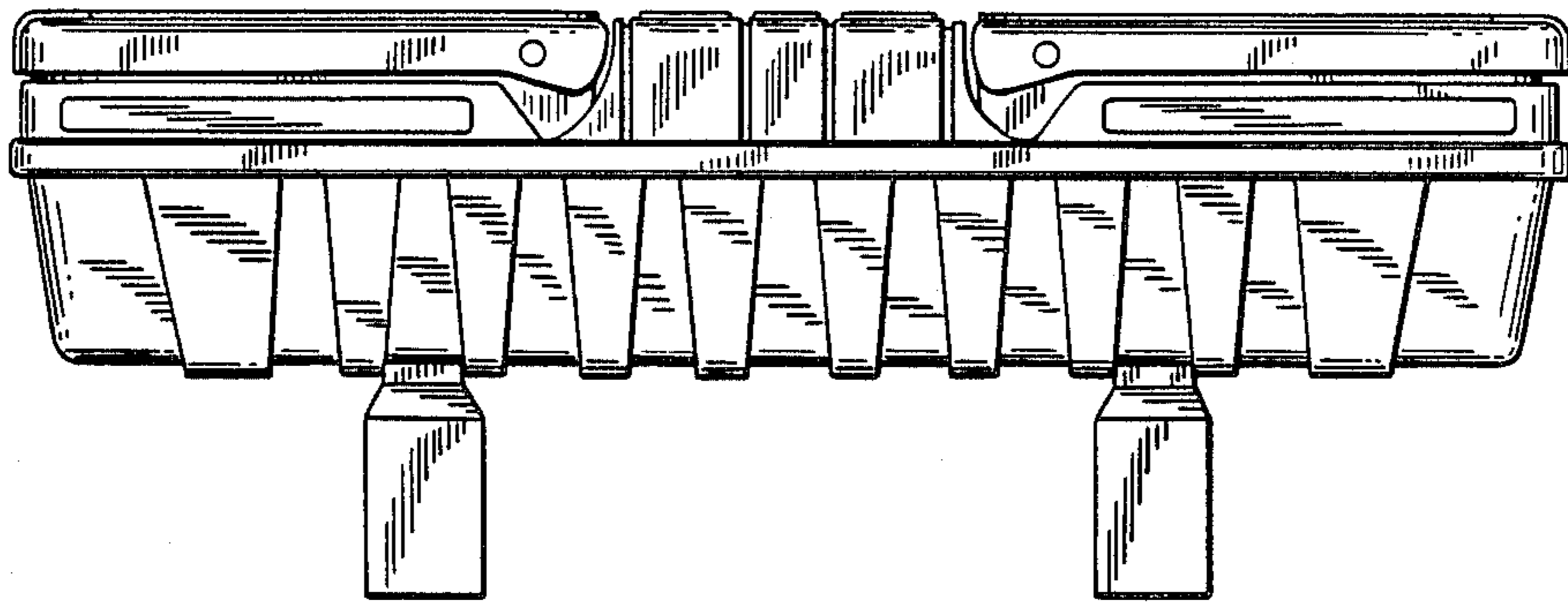

FIG. 1

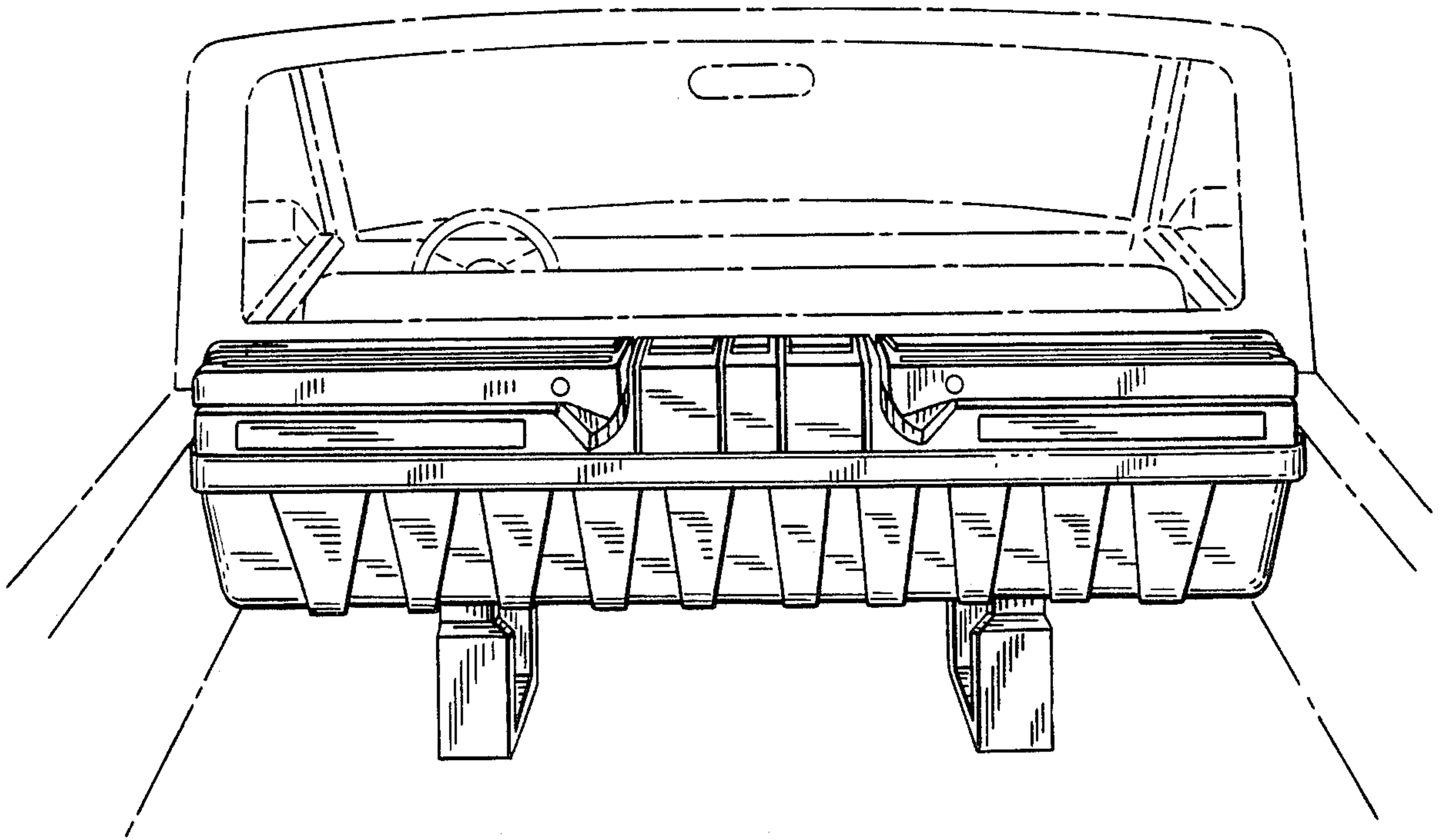

FIG. 2

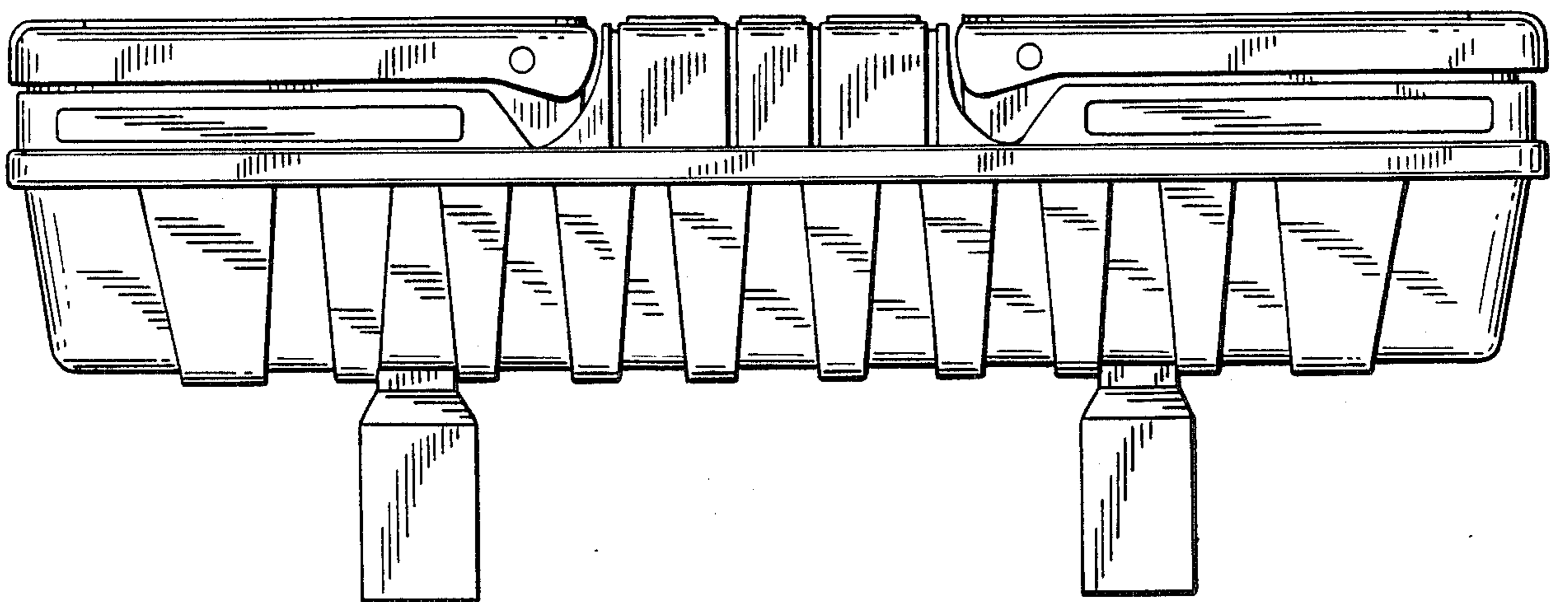

FIG. 3

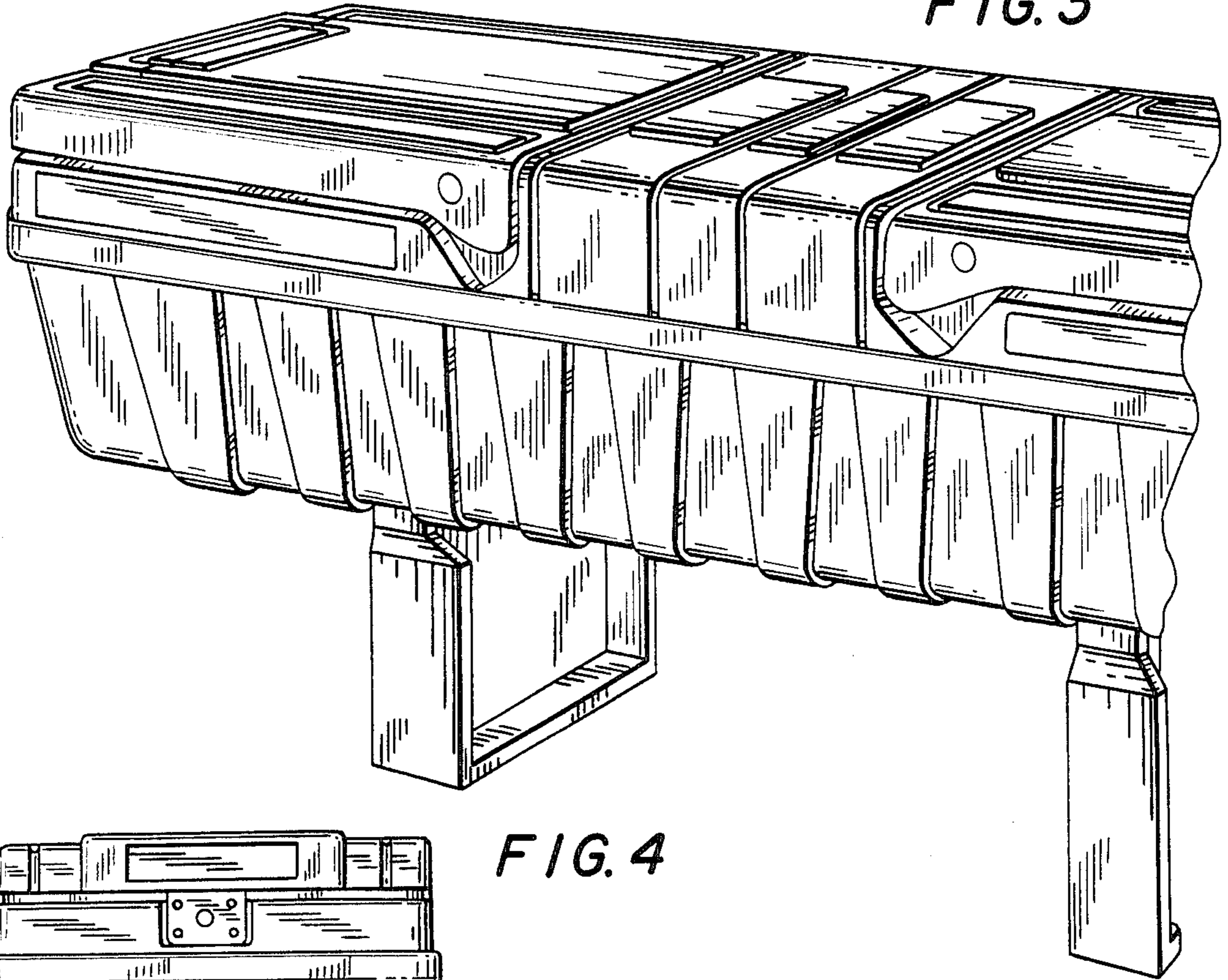

FIG. 4

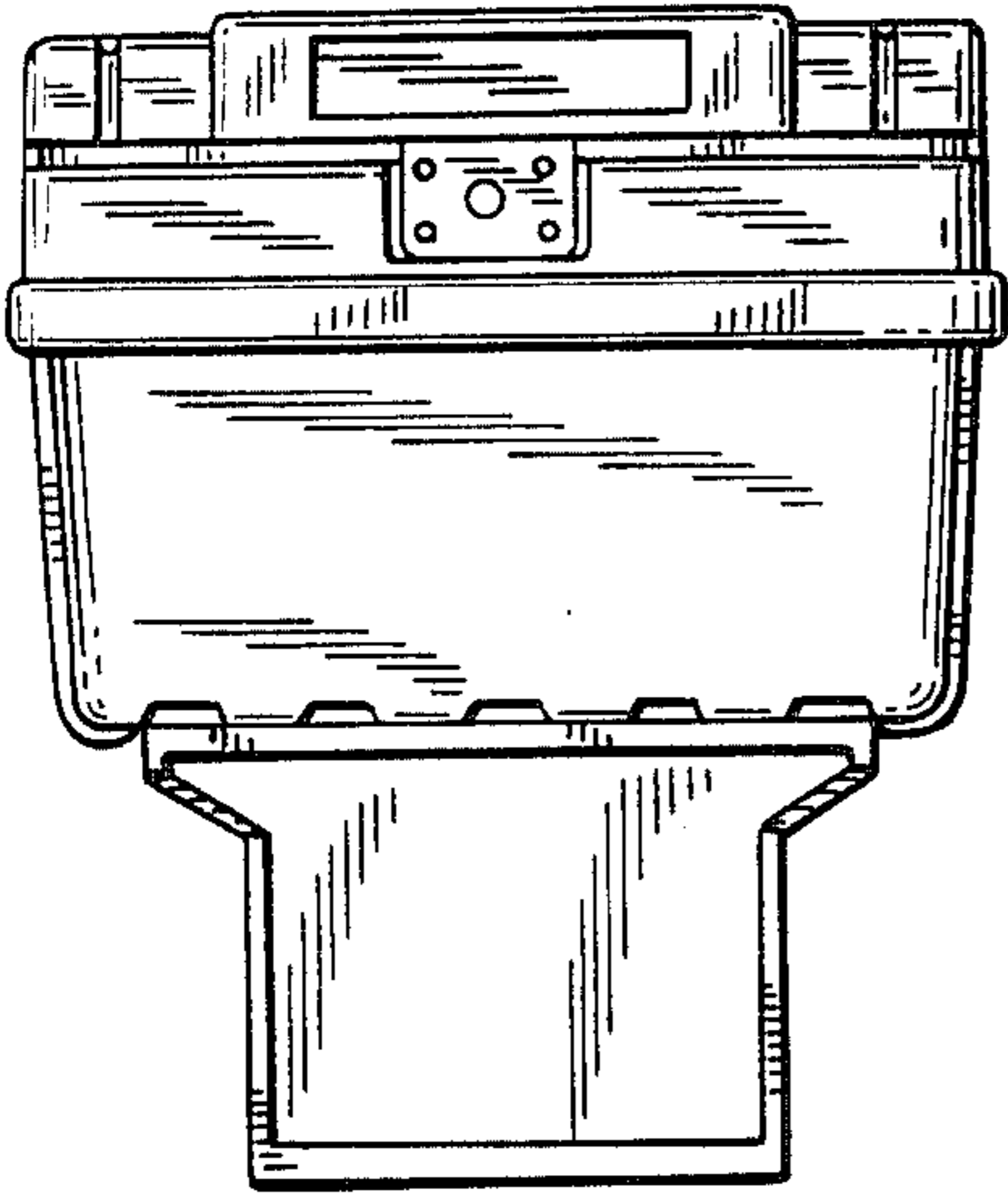
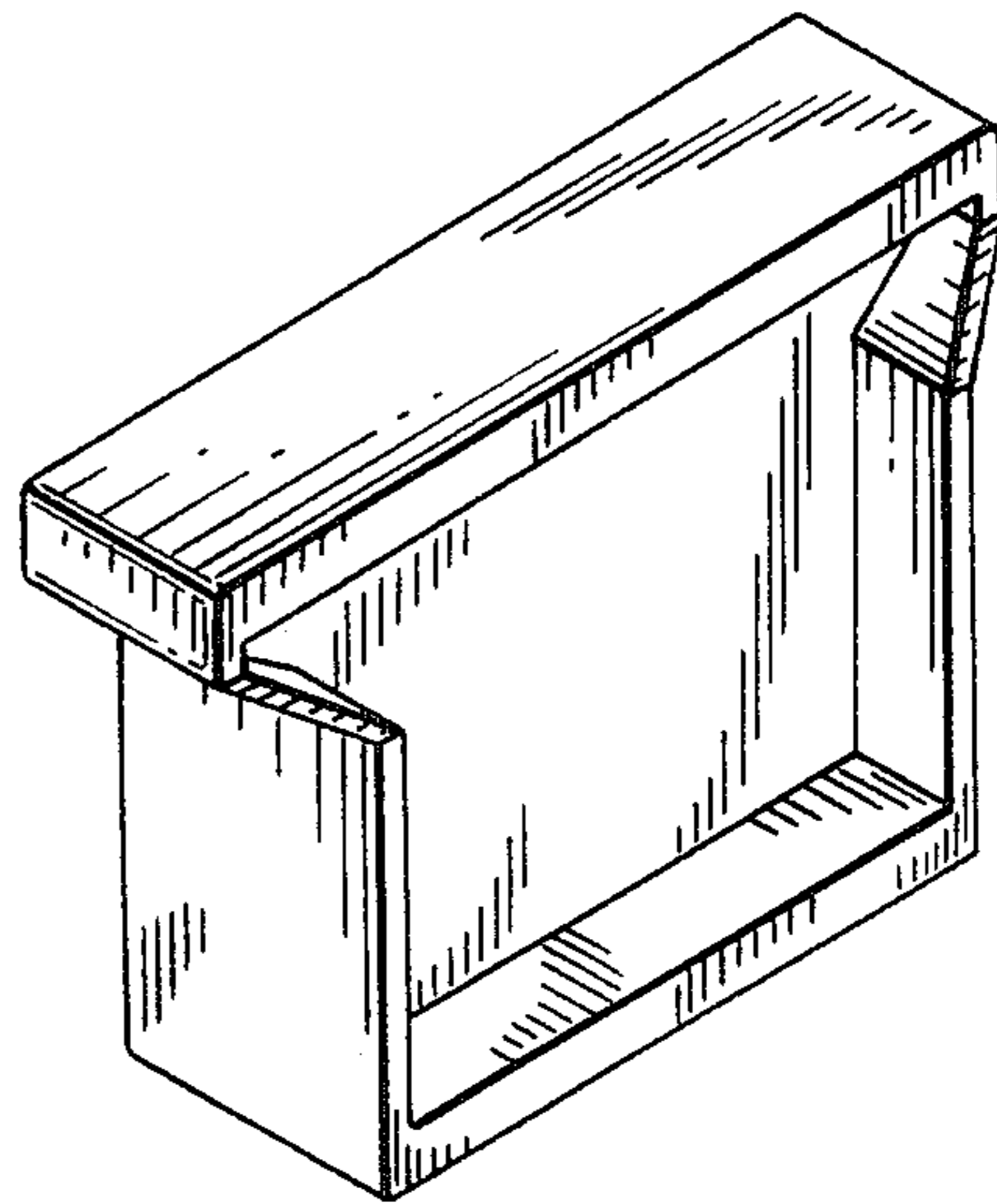

FIG. 5



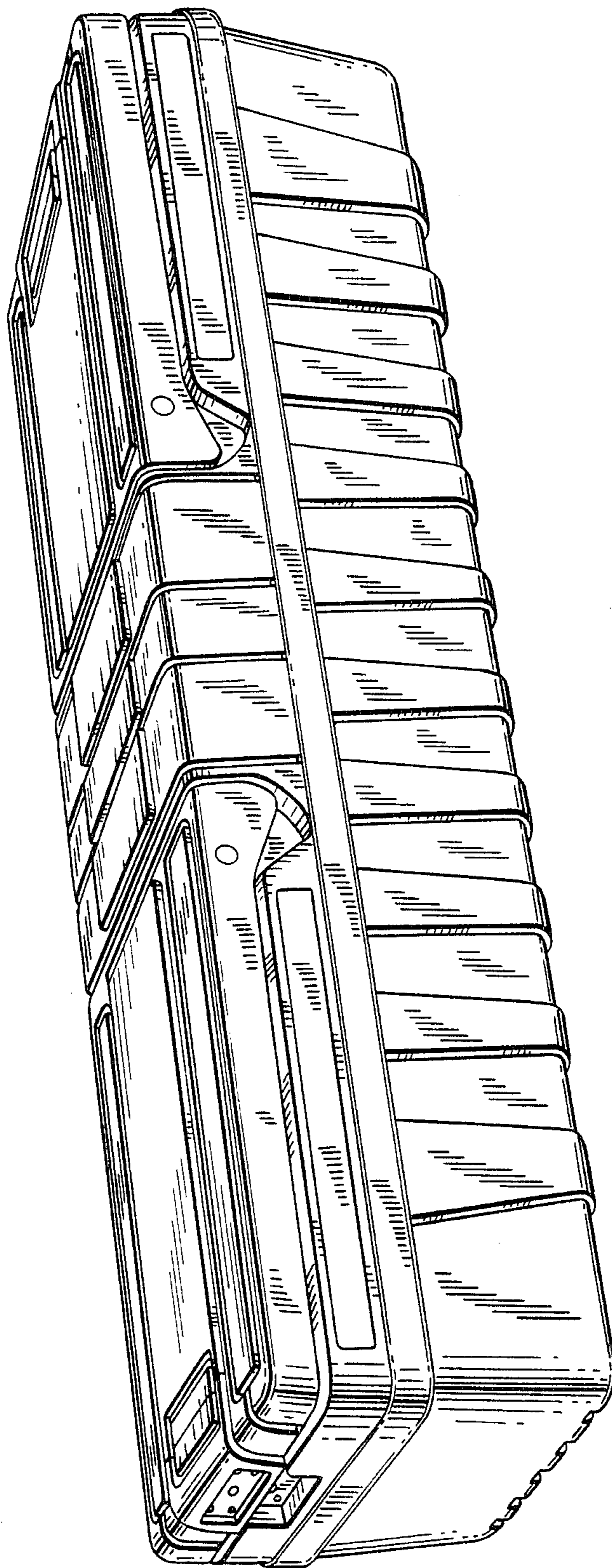

FIG. 6