

[54] **MOTOR VEHICLE BODY**

[75] **Inventors: Carlo Carpanelli; Stefano Serenari,**
both of Bologna, Italy

[73] **Assignee: GO PRO S.r.l., Bologna, Italy**

[**] **Term: 14 Years**

[21] **Appl. No.: 769,948**

[22] **Filed: Aug. 27, 1985**

[52] **U.S. Cl. D12/88; D12/87**

[58] **Field of Search D12/87, 88; 296/1.5,**
296/186, 205, 185

[56] **References Cited**

U.S. PATENT DOCUMENTS

- D. 191,579 10/1961 Thompson D12/88
- D. 238,485 1/1976 Baldwin D12/107
- D. 268,746 4/1983 Greenhalgh et al. D12/88

OTHER PUBLICATIONS

Design News, 4/21/75, p. 22, Dune-Buggy.

Primary Examiner—James M. Gandy
Attorney, Agent, or Firm—Balogh, Osann, Kramer,
Dvorak, Genova & Traub

[57] **CLAIM**

The ornamental design for a motor vehicle body, as shown and described.

DESCRIPTION

FIG. 1 is a perspective view of a motor vehicle body, showing our new design, it being understood that the broken lines are for illustrative purposes only and form no part of the claimed design.

FIG. 2 is a side elevation view thereof.

FIG. 3 is a front elevation view thereof.

FIG. 4 is a rear elevation view thereof.

FIG. 5 is a top plan view thereof.

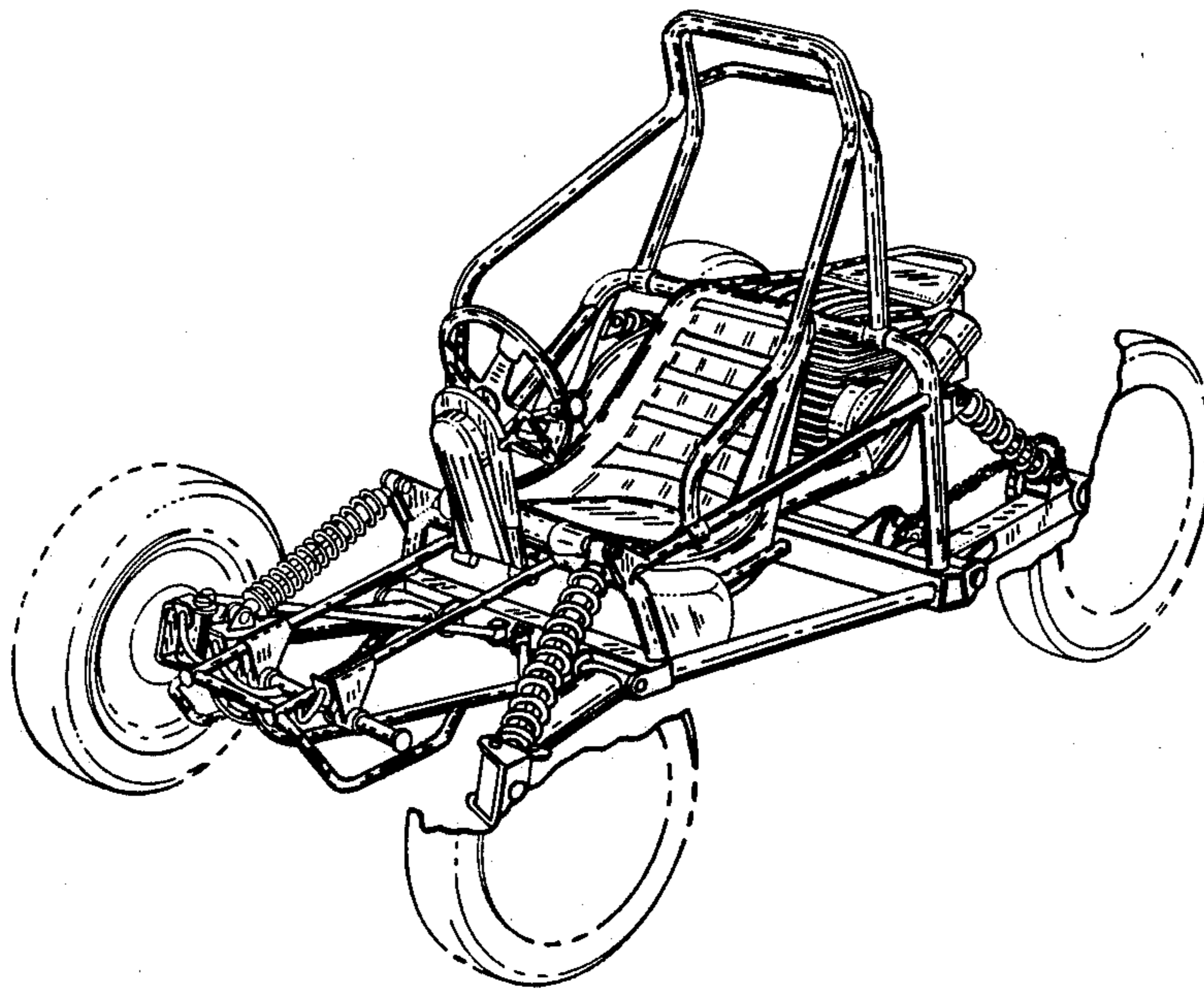

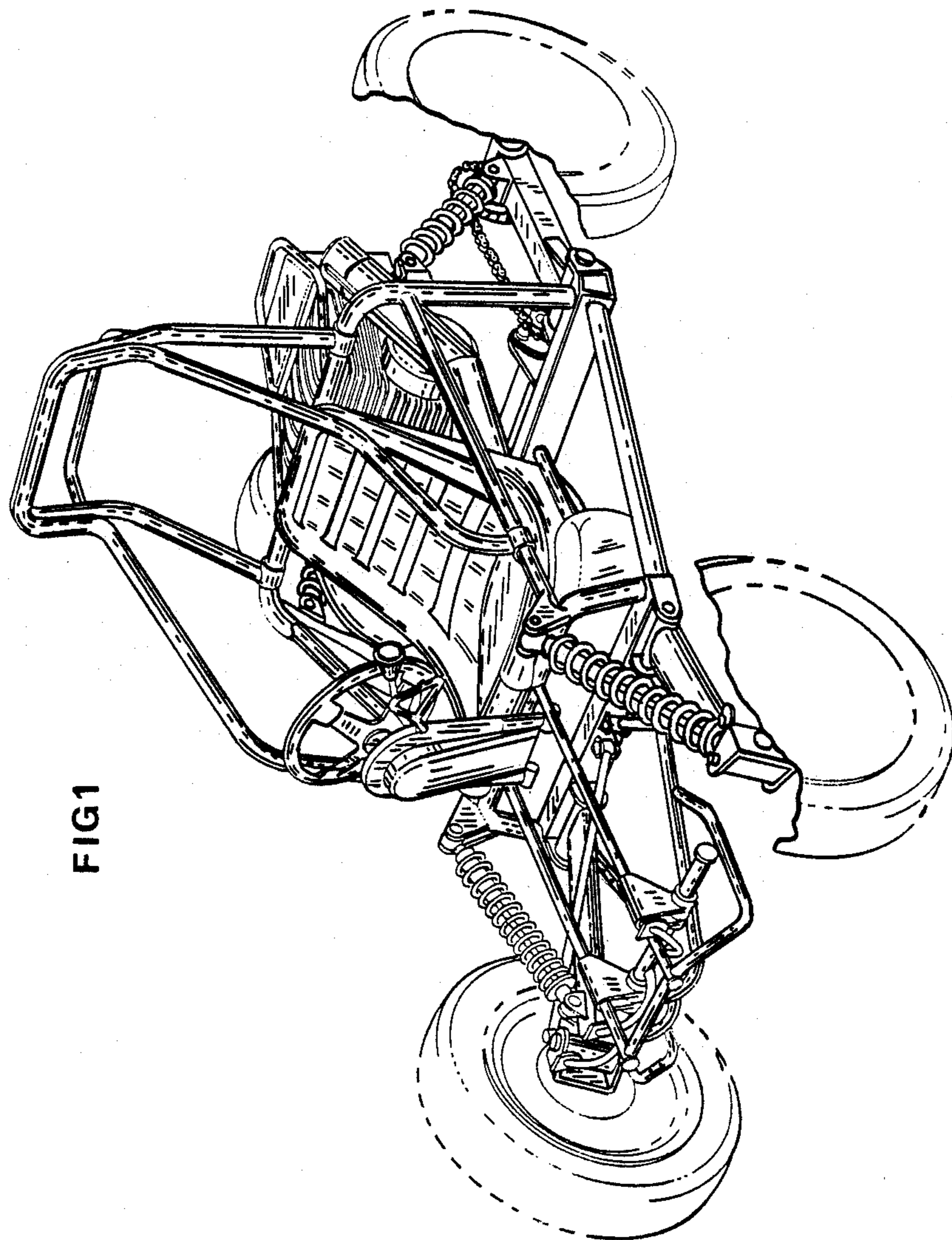

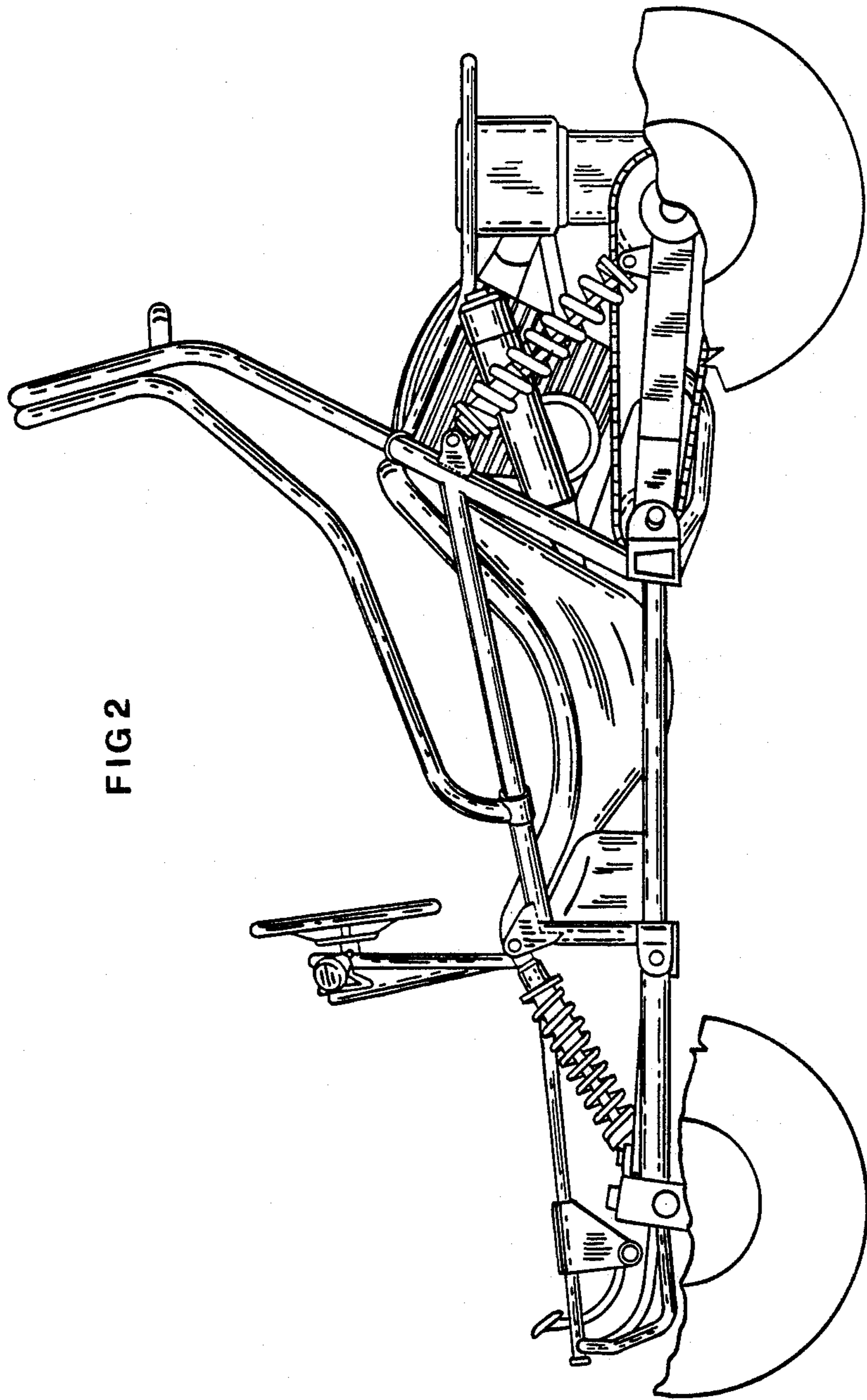
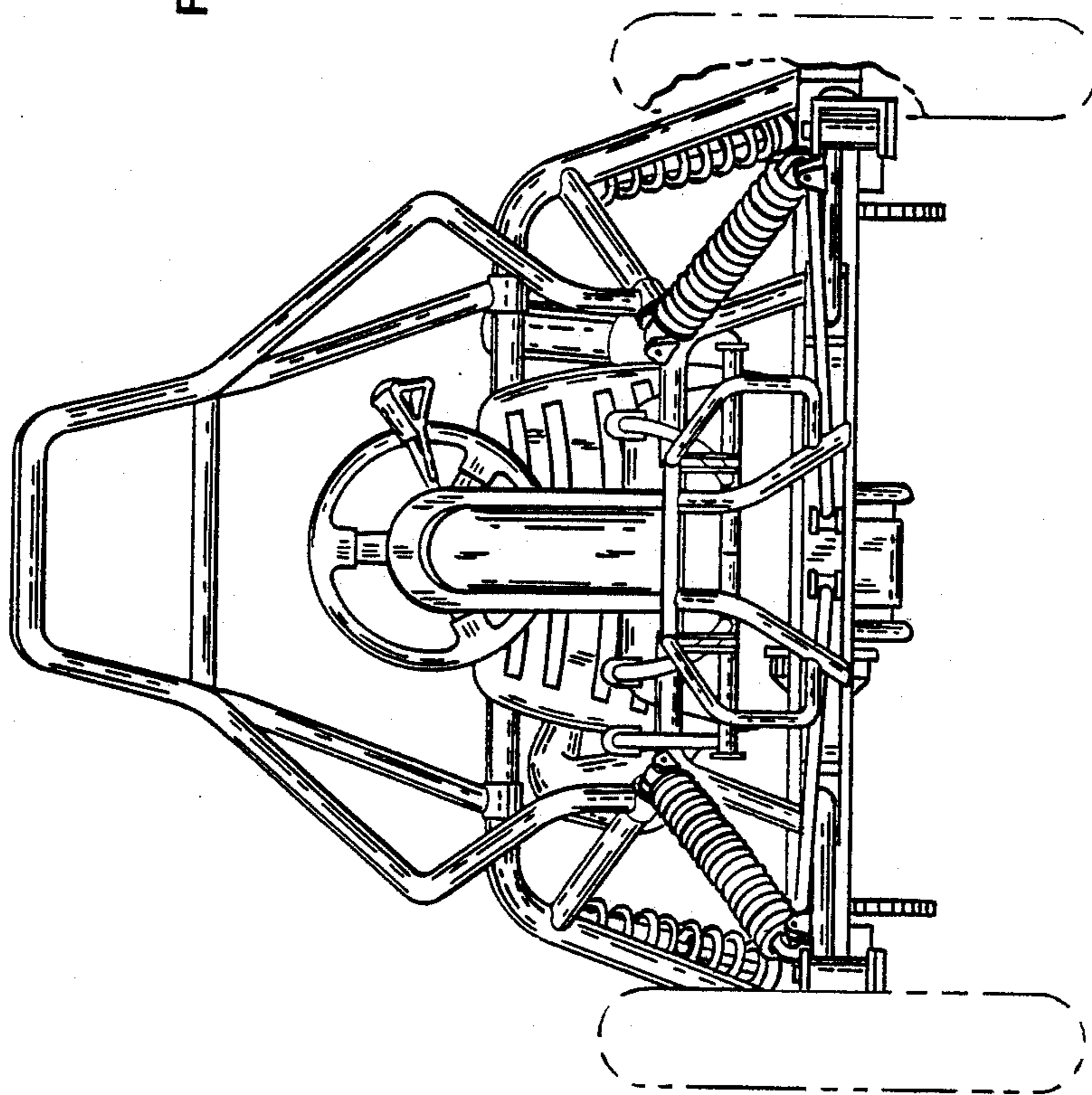

FIG 2

FIG 3



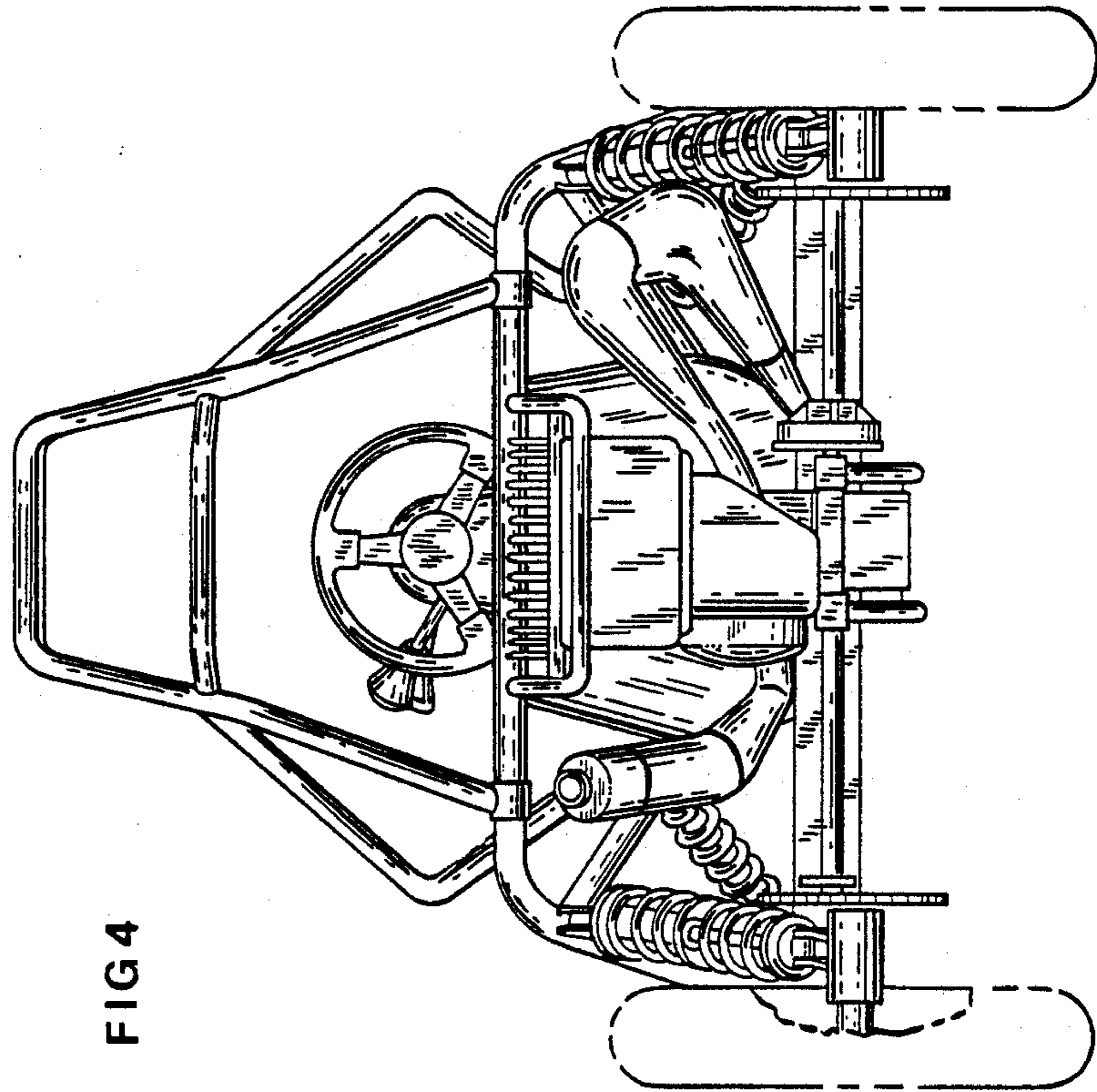

FIG 4

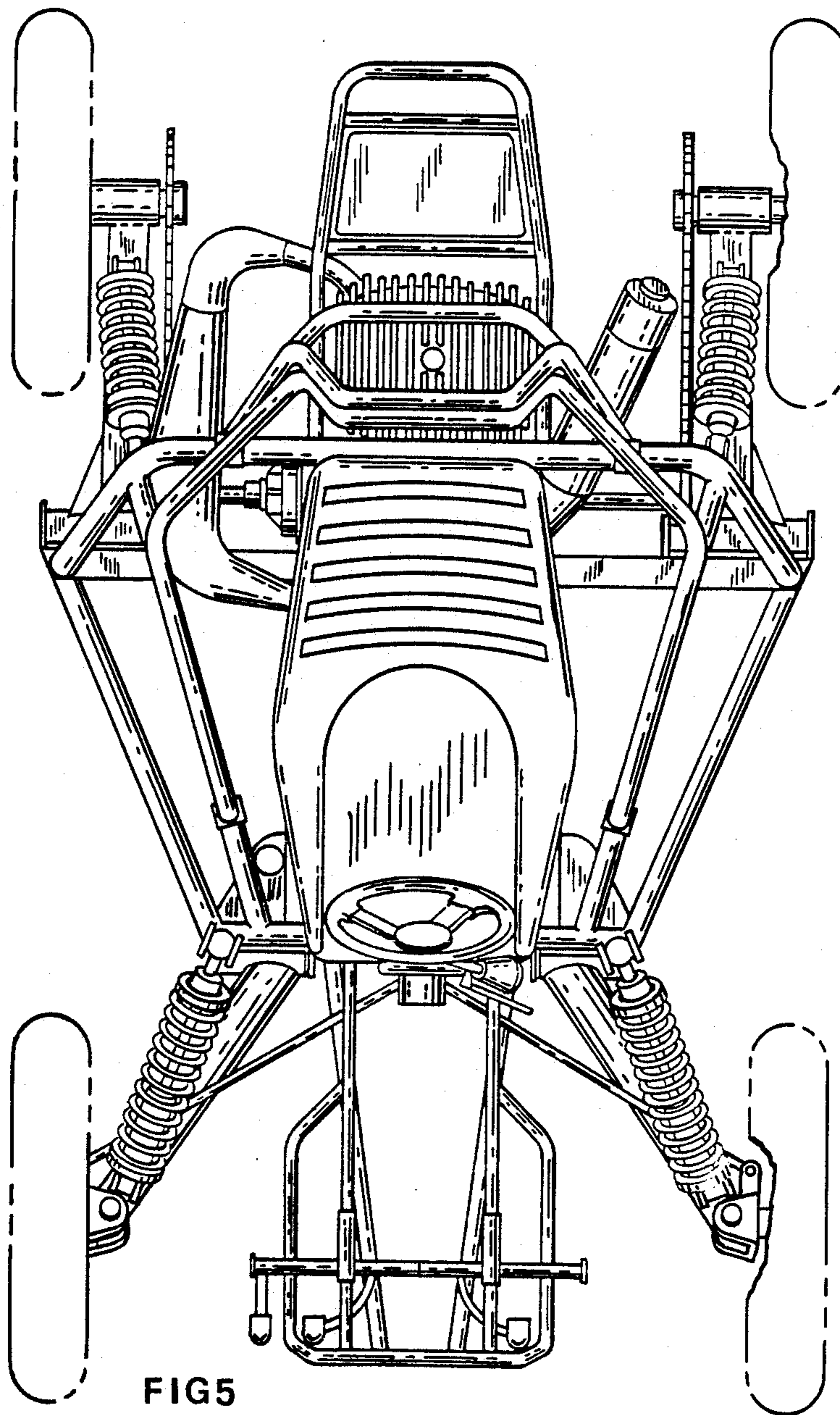

FIG 5