

[54] COMBINED COURTESY AND ADJUSTABLE LIGHT FOR THE INTERIOR OF AUTOMOTIVE VEHICLES

D. 291,253 8/1987 Ortega D26/74 X
D. 294,302 2/1988 Littrell et al. D26/80 X
2,654,830 10/1953 Runge et al. 362/269
2,665,372 1/1954 Wyman et al. 362/269 X
4,499,528 2/1985 Hawlitzki 362/61 X

[76] Inventor: Anthony F. Macaluso, 6833 Rosecrans Ave., Unit D, Paramount, Calif. 90723

Primary Examiner—Susan J. Lucas
Attorney, Agent, or Firm—Fulwider, Patton, Rieber, Lee & Utecht

[**] Term: 14 Years

[57] CLAIM

[21] Appl. No.: 923,659

The ornamental design for a combined courtesy and adjustable light for the interior of automotive vehicles, as shown and described.

[22] Filed: Oct. 24, 1986

[52] U.S. Cl. D26/29; D26/61; D26/72

DESCRIPTION

[58] Field of Search D26/28, 29, 61, 63, D26/65, 74, 72; 362/432, 269, 74, 61, 245, 246, 250, 364, 270, 371

FIG. 1 is a bottom plan view of a combined courtesy and adjustable light for the interior of automotive vehicles showing my new design;

[56] References Cited

U.S. PATENT DOCUMENTS

FIG. 2 is a side elevational view thereof, the opposite side being a mirror image;

D. 264,007 4/1982 Heritage D26/74
D. 264,253 5/1982 Goldschmidt et al. D26/72 X

FIG. 3 is a front elevational view thereof, the rear being a mirror image;

FIG. 4 is a top plan view thereof.

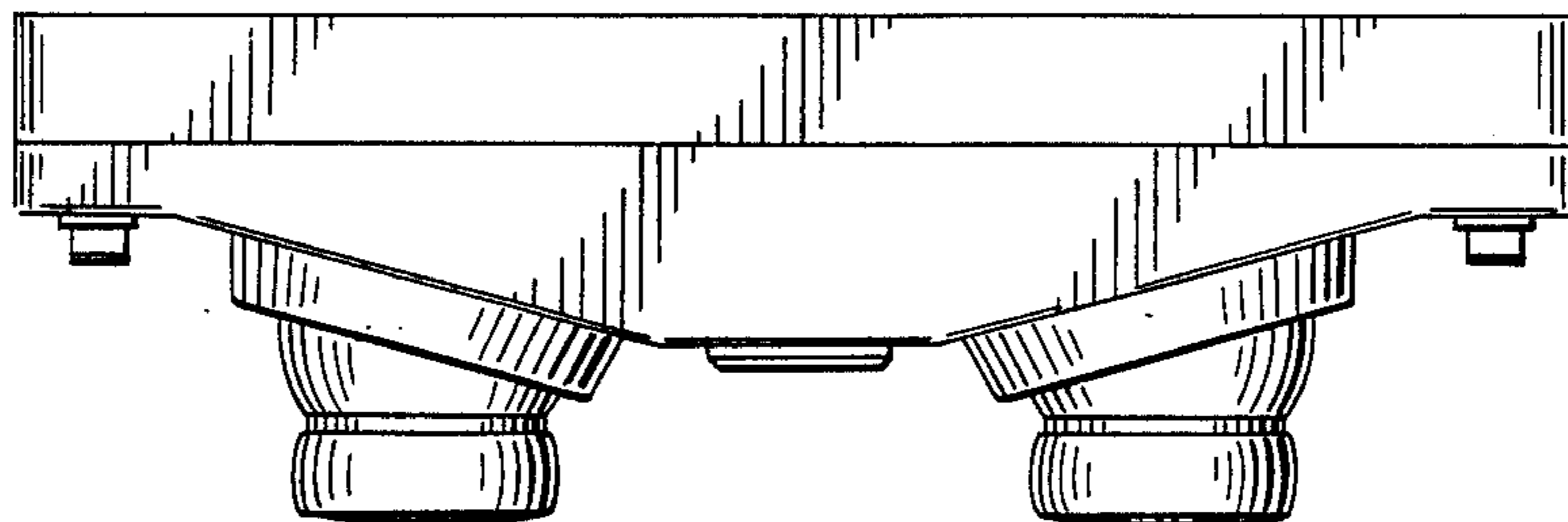
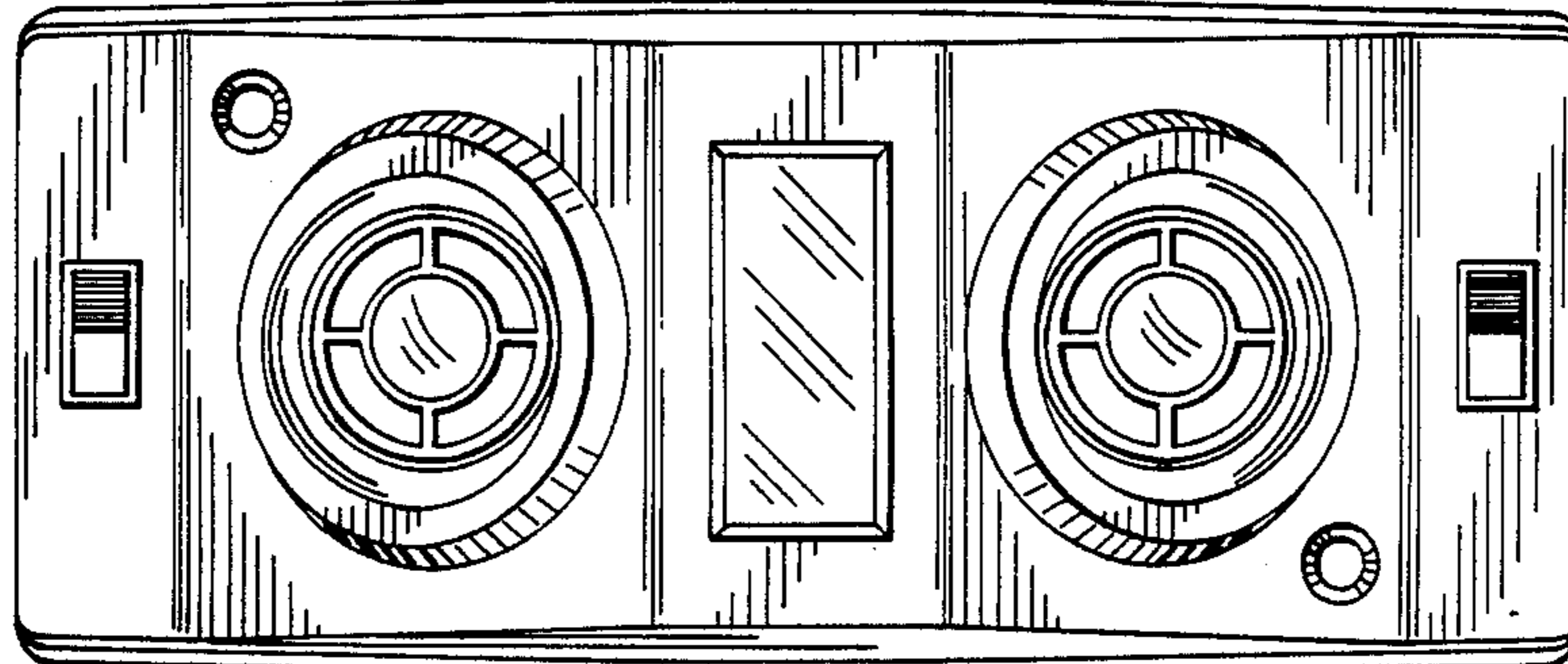

FIG. 1

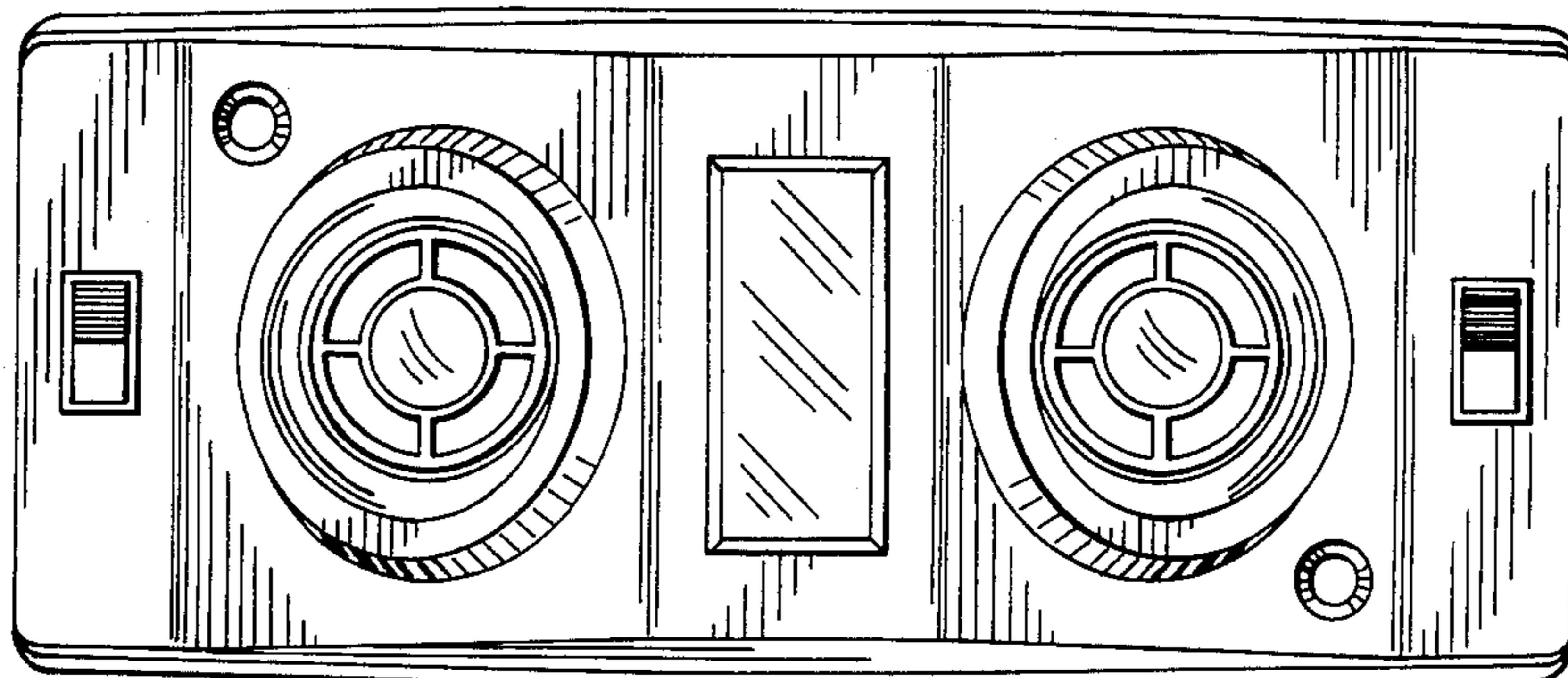

FIG. 2

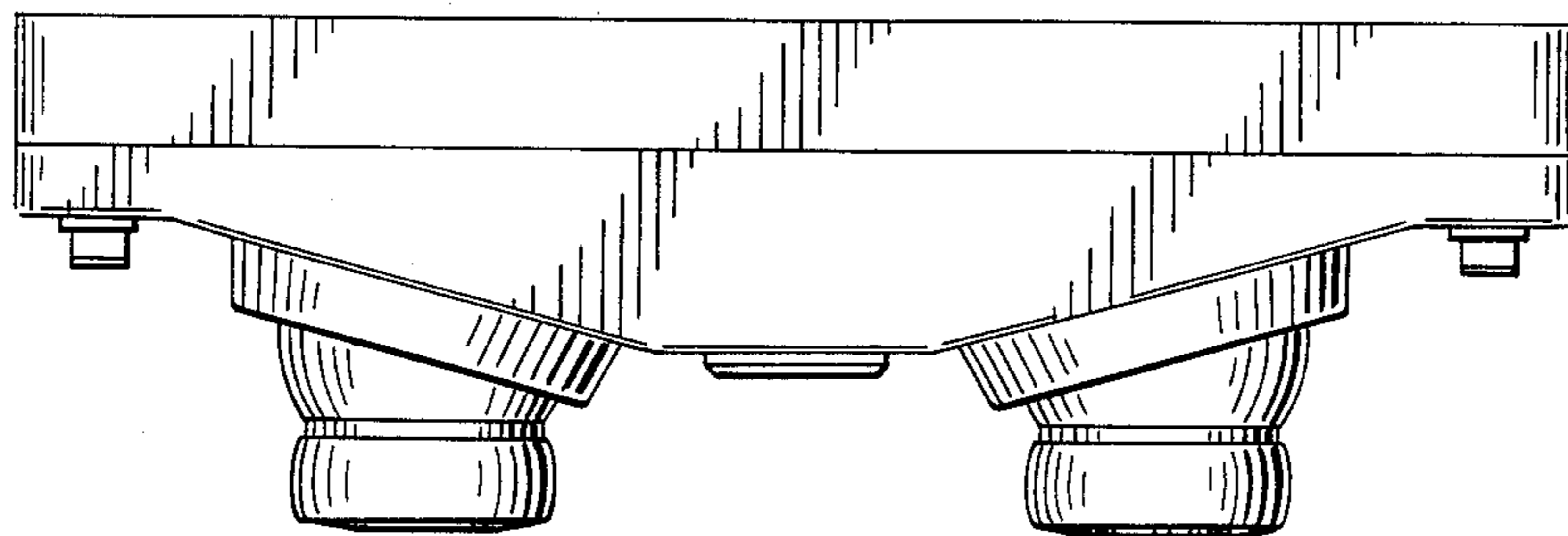

FIG. 3

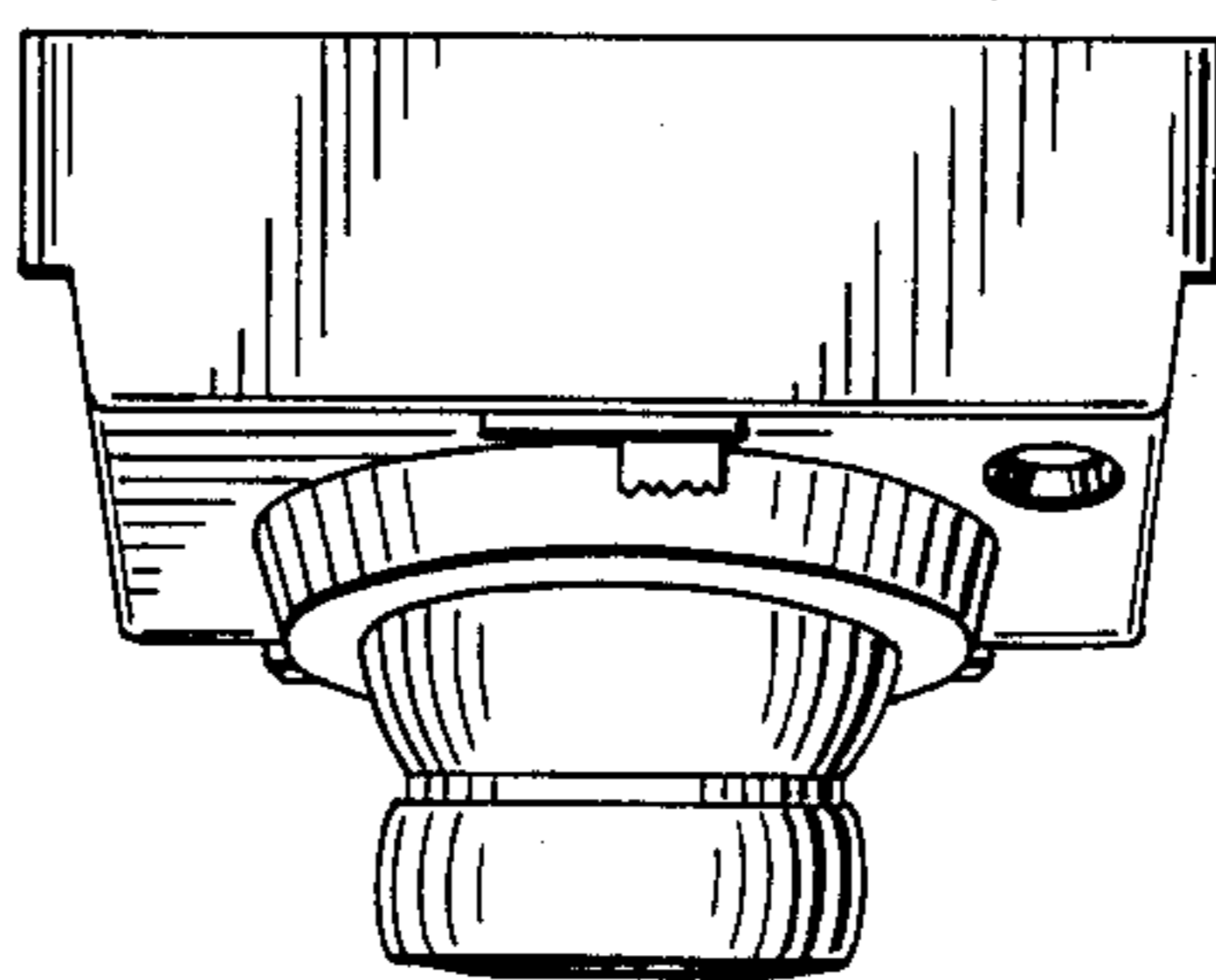

FIG. 4

