

[54] FOUR WHEELED VEHICLE

[75] Inventors: Yasuhiro Oba, Iruma; Mitsuru Yamamoto, Fujimi; Akira Watanabe, Setagaya, all of Japan

[73] Assignee: Honda Giken Kogyo Kabushiki Kaisha, Tokyo, Japan

[**] Term: 14 Years

[21] Appl. No.: 850,378

[22] Filed: Apr. 7, 1986

[30] Foreign Application Priority Data

Oct. 14, 1985 [JP] Japan 60-42939

[52] U.S. Cl. D12/86; D12/3; D12/107

[58] Field of Search D12/3, 86, 85, 107, D12/110; D15/15, 23; 180/219, 225, 229, 233, 311, 312

[56] References Cited

U.S. PATENT DOCUMENTS

D. 222,242	10/1971	Delaney et al.	D12/16
D. 242,439	11/1976	Gervais	D12/16
D. 245,242	8/1977	Stolley	D12/16
D. 289,986	5/1987	Ooba et al.	D12/107
D. 293,900	1/1988	Murakami	D12/107

Primary Examiner—James M. Gandy
Attorney, Agent, or Firm—Kane, Dalsimer, Sullivan, Kurucz, Levy, Eisele and Richard

[57] CLAIM

The ornamental design for a four wheeled vehicle, as shown.

DESCRIPTION

FIG. 1 is a front perspective view of a four wheeled vehicle showing our new design;
FIG. 2 is a rear perspective view thereof;
FIG. 3 is a top plan view thereof;
FIG. 4 is a bottom plan view thereof;
FIG. 5 is a right side perspective view thereof; and
FIG. 6 is a left, front perspective view thereof.

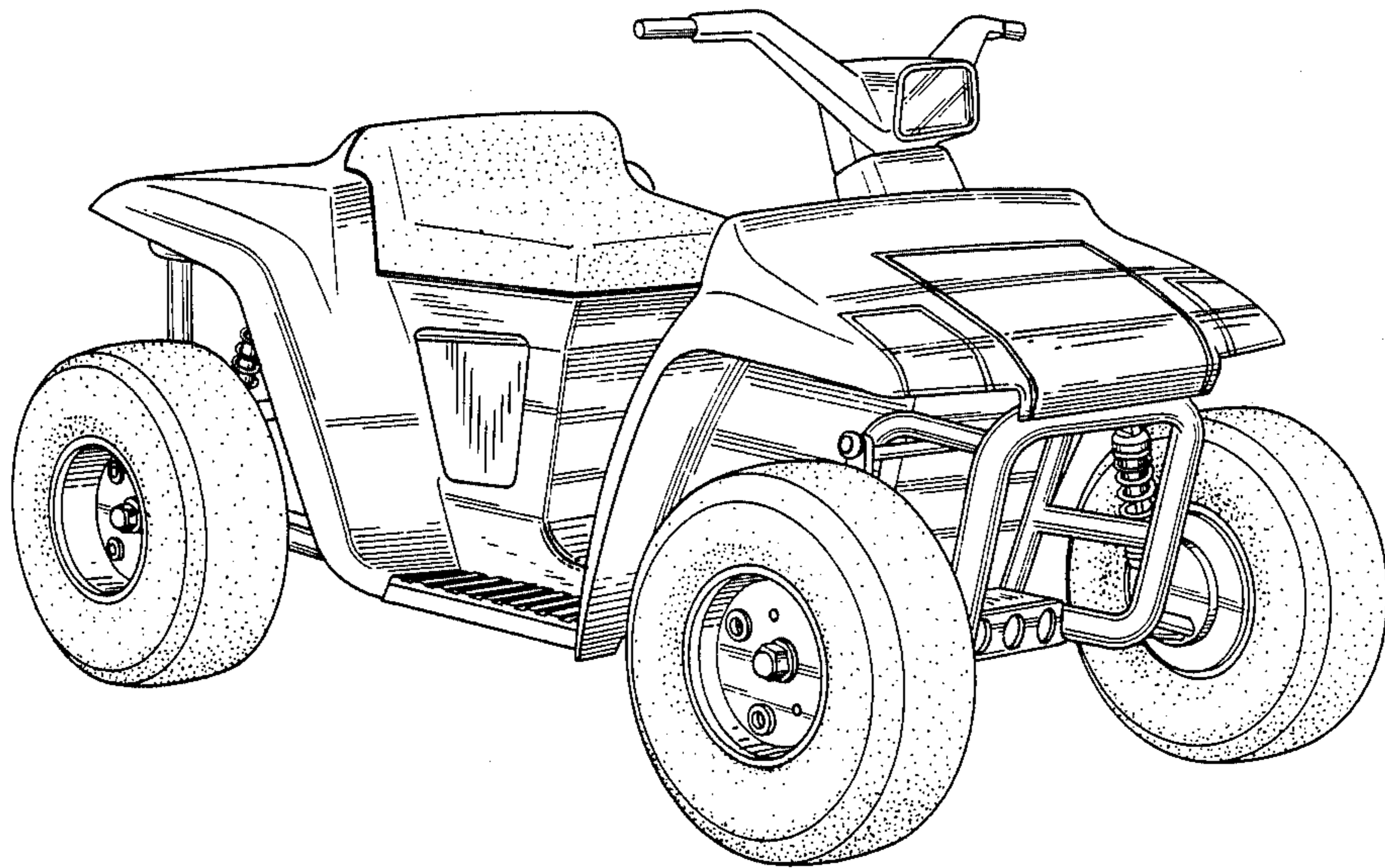

FIG. 1

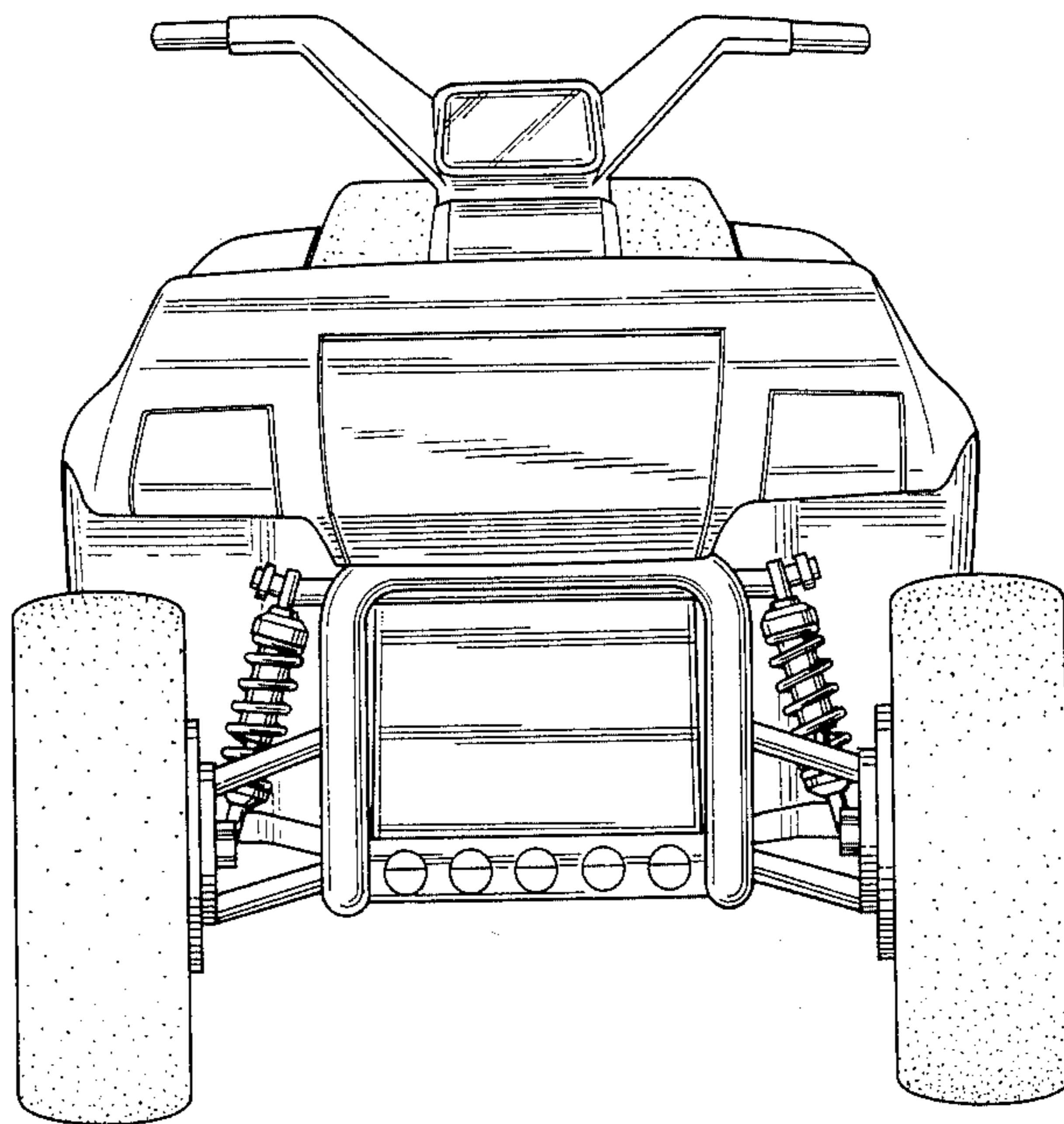

FIG. 2

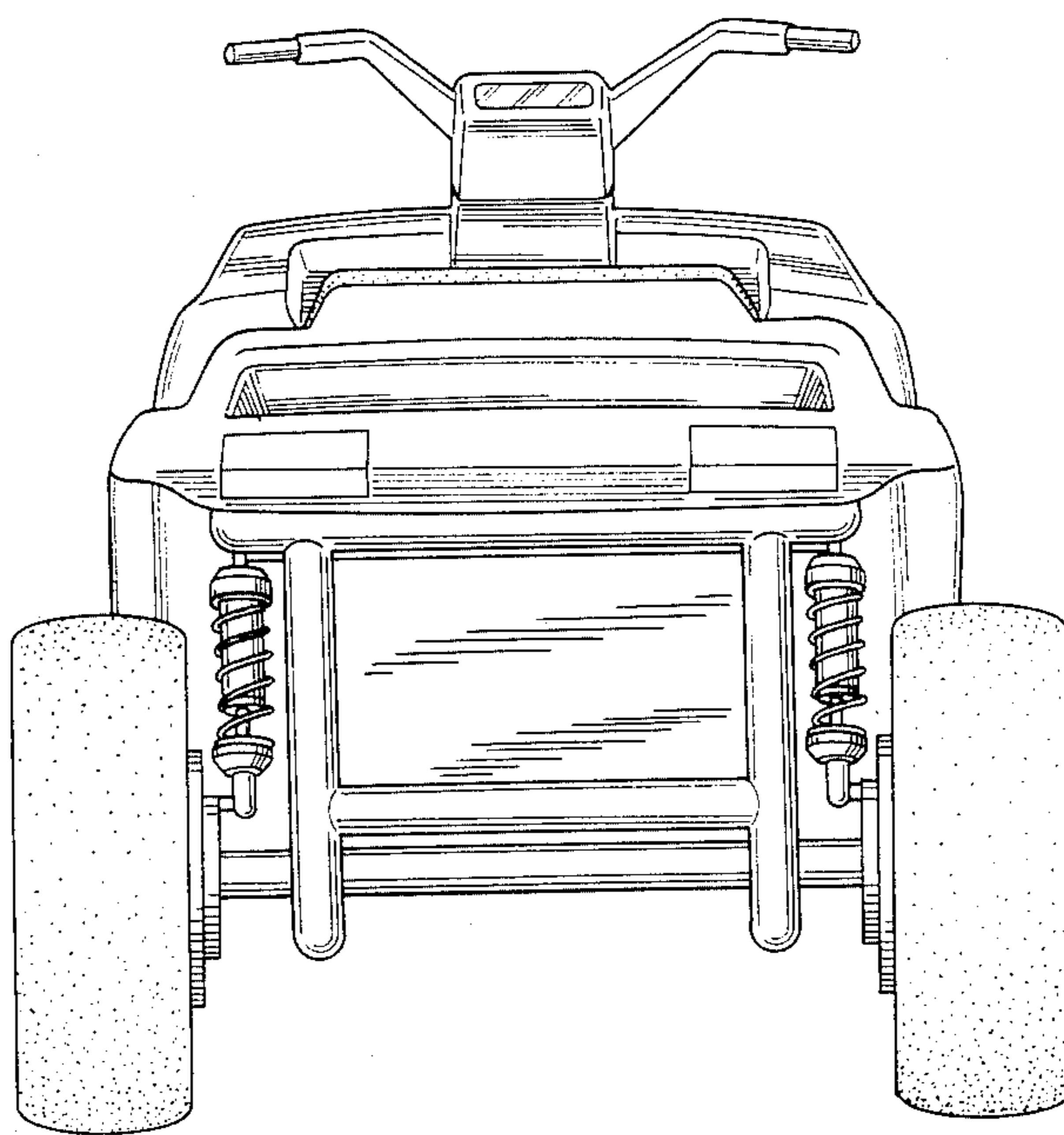

FIG. 3

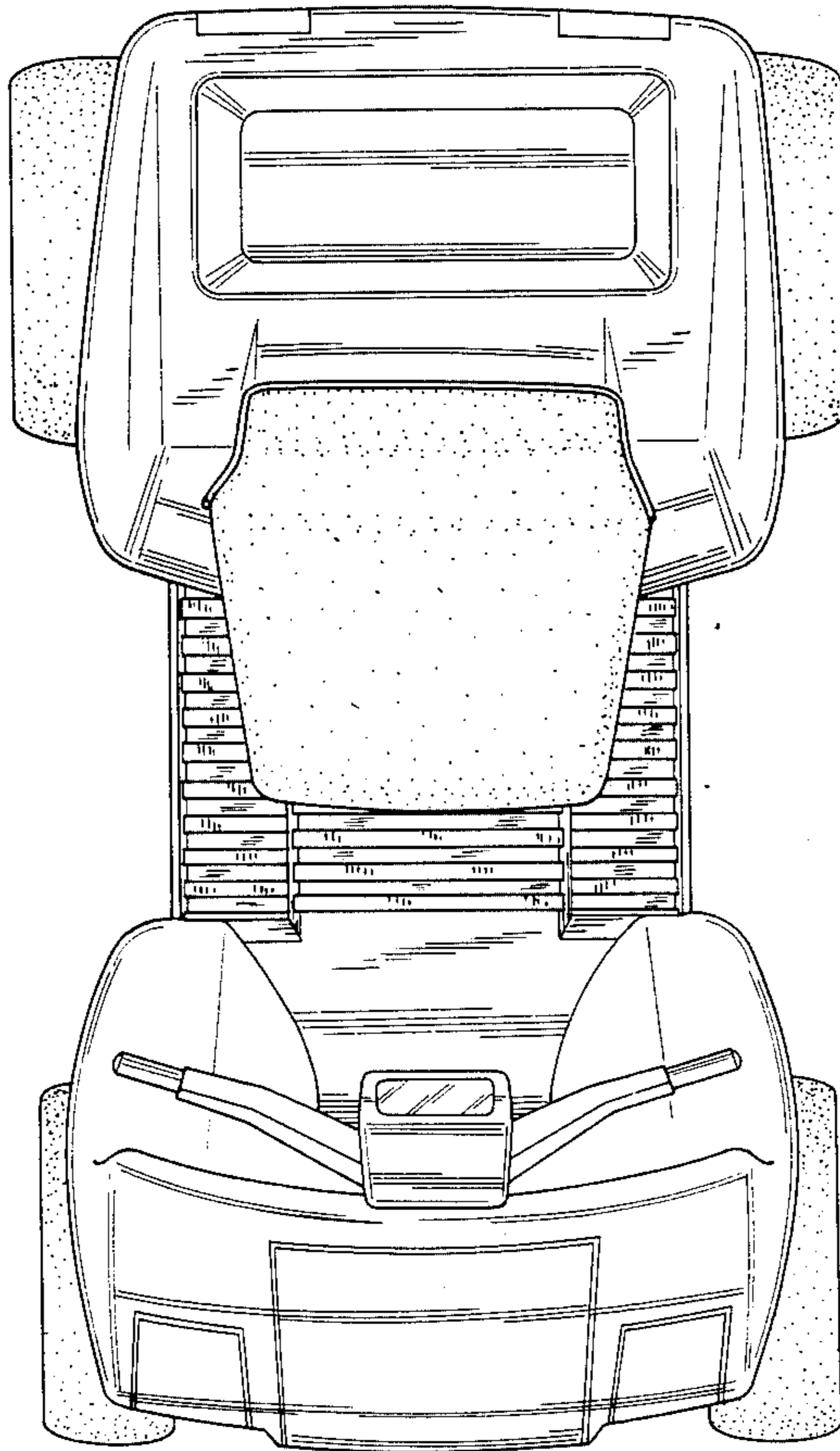

FIG. 4

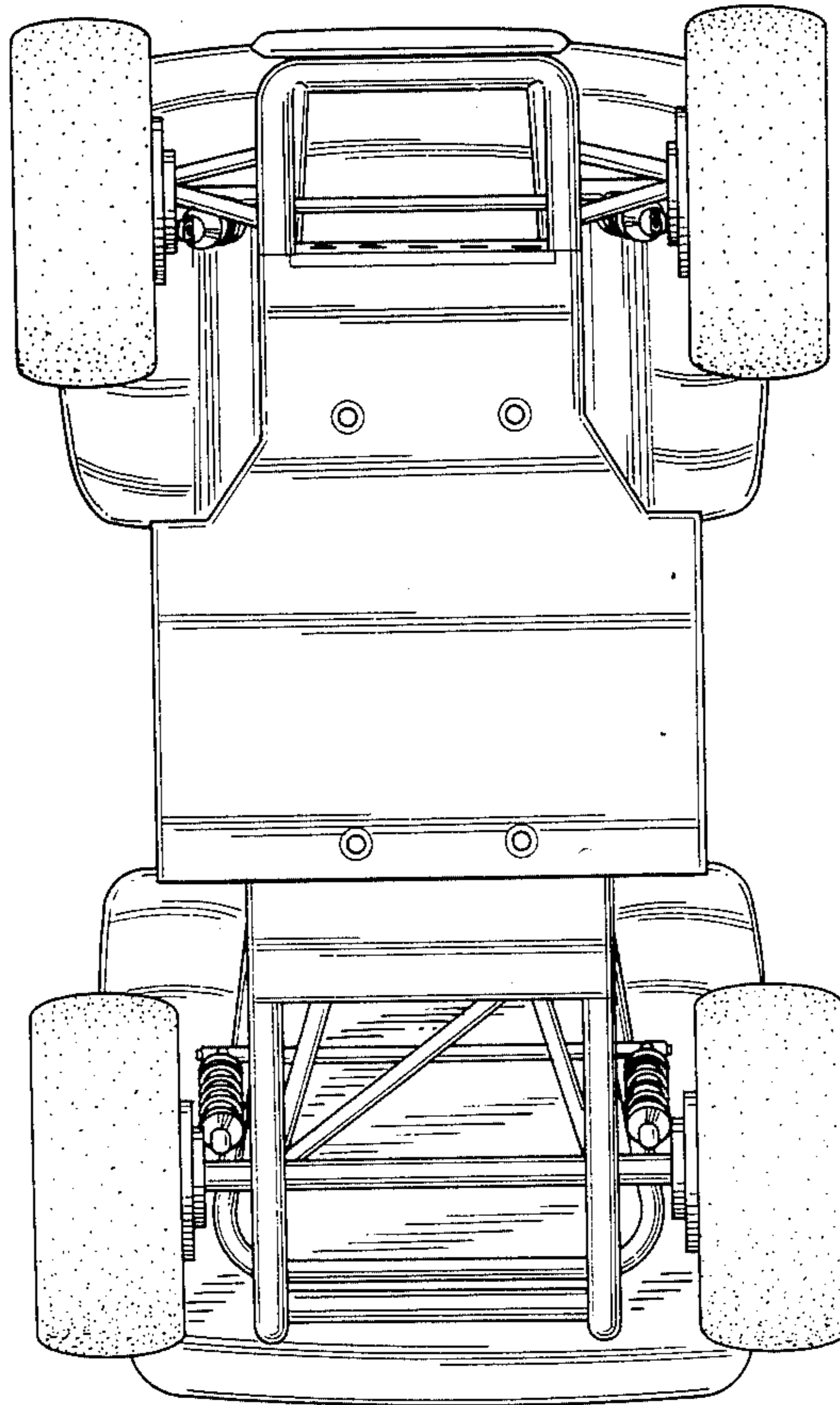

FIG. 5

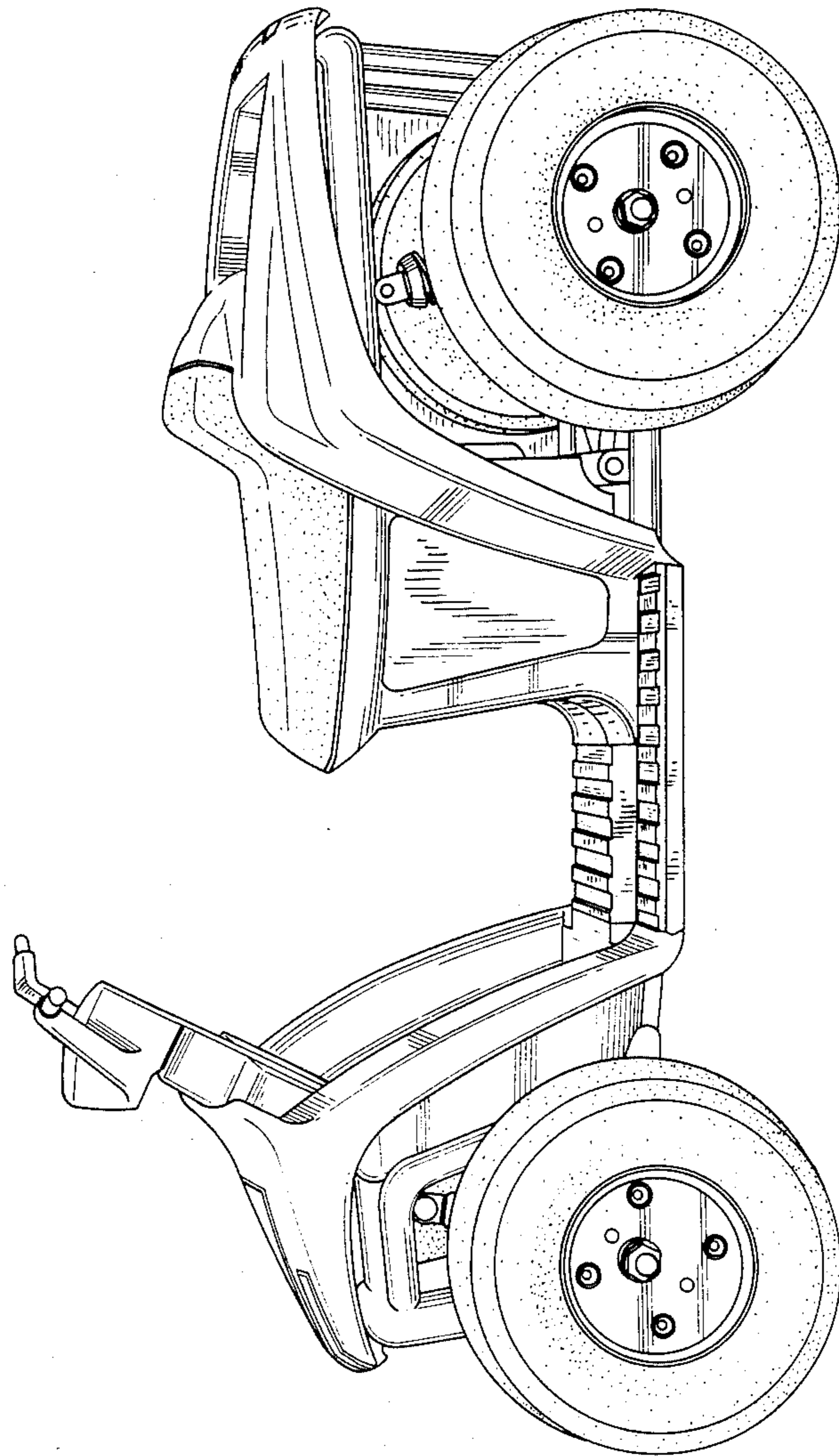

FIG. 6

