

[54] **TUBE FOR RECTAL ADMINISTRATION OF PHARMACEUTICAL COMPOSITIONS**

[75] **Inventor: John F. Christensen, Copenhagen, Denmark**

[73] **Assignee: AB Akerlund & Rausing, Sweden**

[\*\*] **Term: 14 Years**

[21] **Appl. No.: 870,695**

[22] **Filed: Jun. 4, 1986**

[52] **U.S. Cl. .... D24/63**

[58] **Field of Search ..... D24/63, 60, 51, 59; 604/11, 15, 18, 197, 218**

[56] **References Cited**

**U.S. PATENT DOCUMENTS**

- D. 233,314 10/1974 Turner et al. .... D24/63 X
- D. 233,914 12/1974 Lofman ..... D24/63
- 2,752,920 7/1956 Kurkjian ..... 604/218

3,032,036 5/1962 Rader et al. .... 604/11

*Primary Examiner*—Wallace R. Burke  
*Assistant Examiner*—Stella M. Reid  
*Attorney, Agent, or Firm*—Lerner, David, Littenberg, Krumholz & Mentlik

[57] **CLAIM**

The ornamental design for a tube for rectal administration of pharmaceutical compositions, as shown and described.

**DESCRIPTION**

FIG. 1 is a perspective view of a tube for rectal administration of pharmaceutical compositions showing my new design;

FIG. 2 is a right side elevational view thereof, the opposite side, top, and bottom being the same in appearance as the side shown;

FIG. 3 is a front elevational view thereof; and  
FIG. 4 is a rear elevational view thereof.

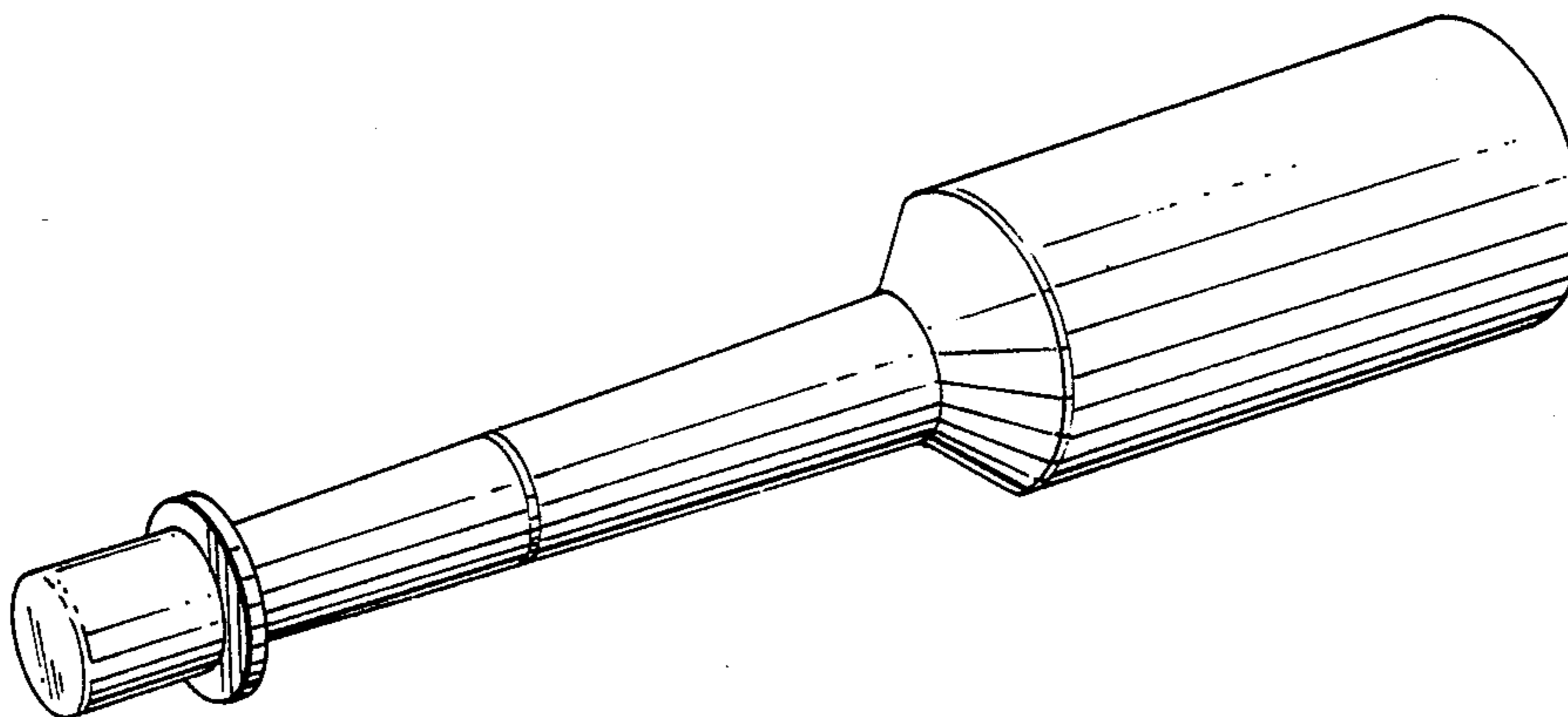

FIG. 1

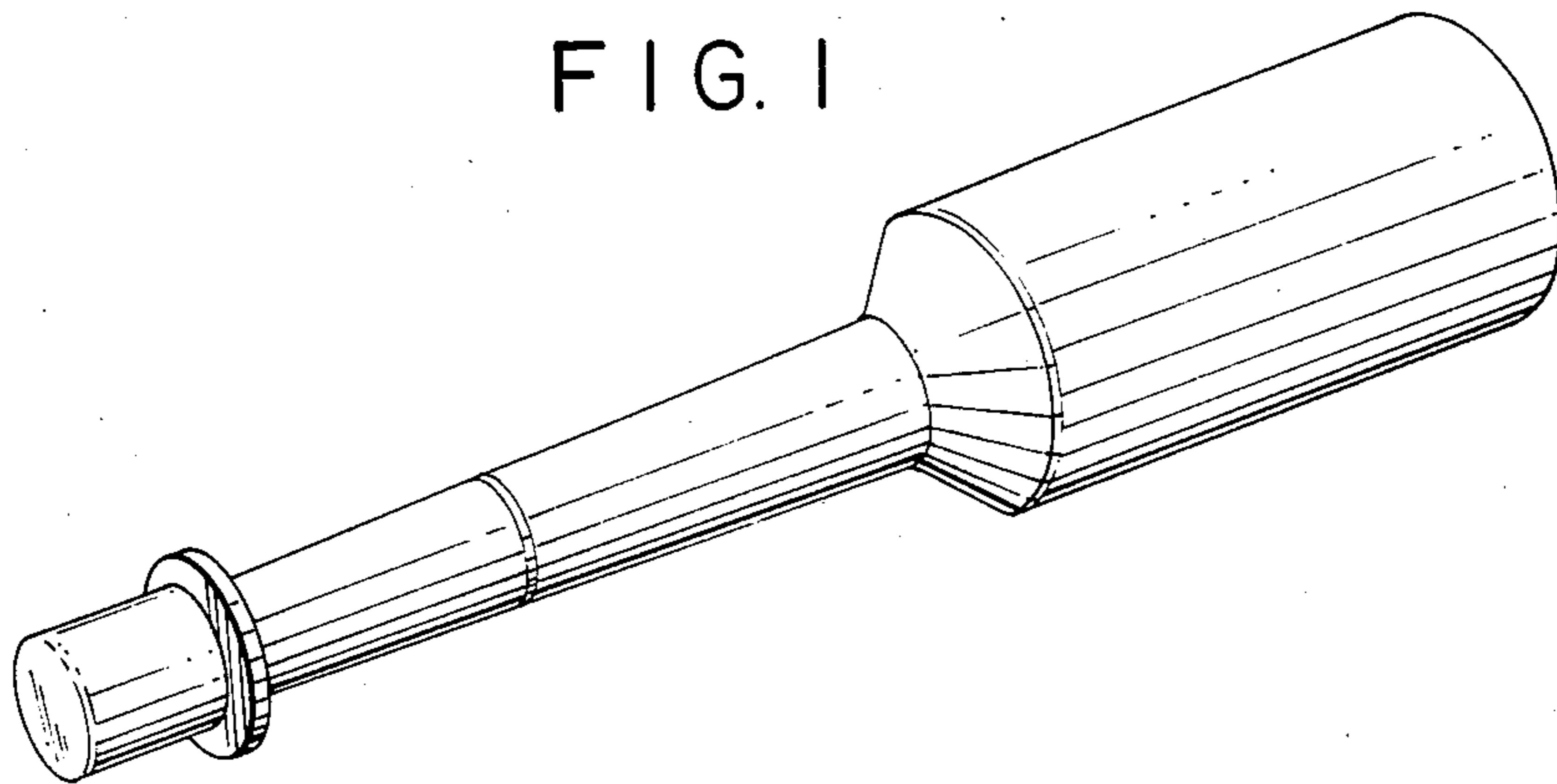

FIG. 2

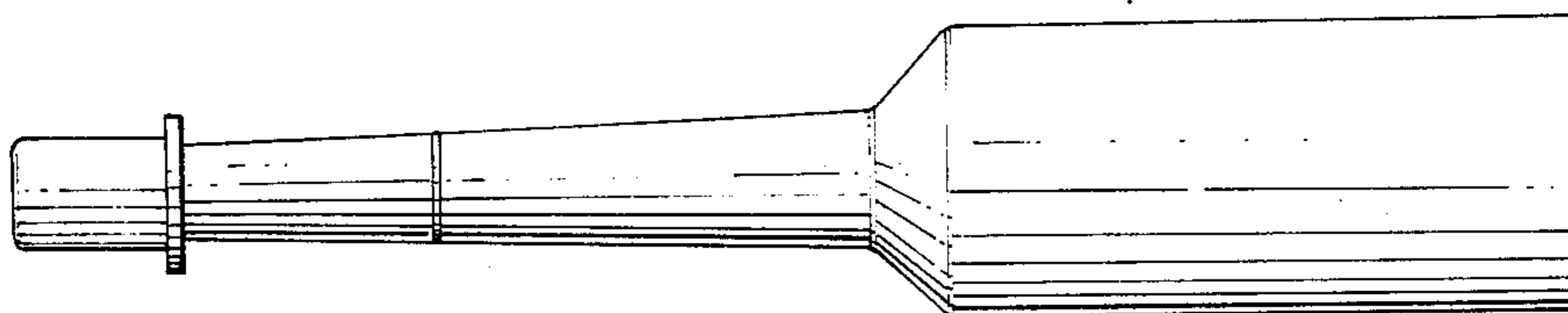

FIG. 3

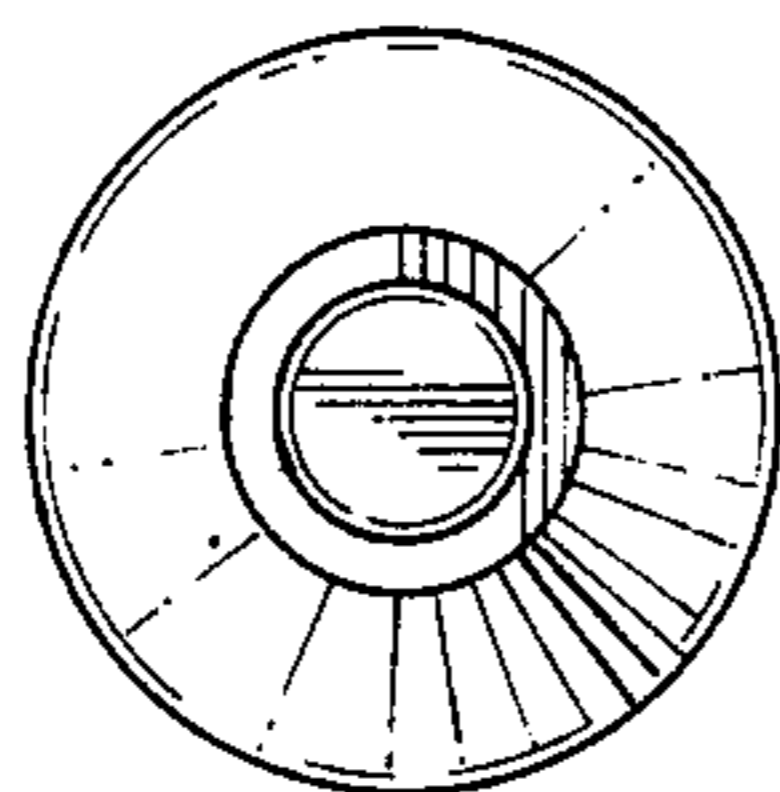

FIG. 4

