

[54] DISTANCE MEASURING DEVICE

[75] Inventor: Masaru Kimura, Osaka, Japan

[73] Assignee: Senshin Kogyo Kabushiki Kaisha, Osaka, Japan

[**] Term: 14 Years

[21] Appl. No.: 889,179

[22] Filed: Jul. 21, 1986

[30] Foreign Application Priority Data

Mar. 27, 1986 [JP] Japan 61-11272

[52] U.S. Cl. D10/70

[58] Field of Search D10/70; 33/141 R, 141 E

[56] References Cited

U.S. PATENT DOCUMENTS

D.136,953 1/1944 Jantzen D10/70

D. 224,046 6/1972 Evans D10/70

D. 233,785 11/1974 Evans D10/70

3,191,310 6/1965 Carlson 33/141 E

3,251,132 5/1966 Hall 33/141 E
3,696,510 10/1972 Evans 33/141 R
4,700,484 10/1987 Frank 33/141 E

Primary Examiner—Nelson C. Holtje
Attorney, Agent, or Firm—Mason, Fenwick & Lawrence

[57] CLAIM

The ornamental design for a distance measuring device, as shown.

DESCRIPTION

FIG. 1 is a front elevational view of a distance measuring device showing my new design;
FIG. 2 is a rear elevational view thereof;
FIG. 3 is a left side elevational view thereof;
FIG. 4 is a right side elevational view thereof;
FIG. 5 is a cross-sectional view of the wheel as taken from line V—V of FIG. 4;
FIG. 6 is a top plan view thereof;
FIG. 7 is a bottom plan view thereof;
FIG. 8 is a front elevational view thereof with the shaft extended.

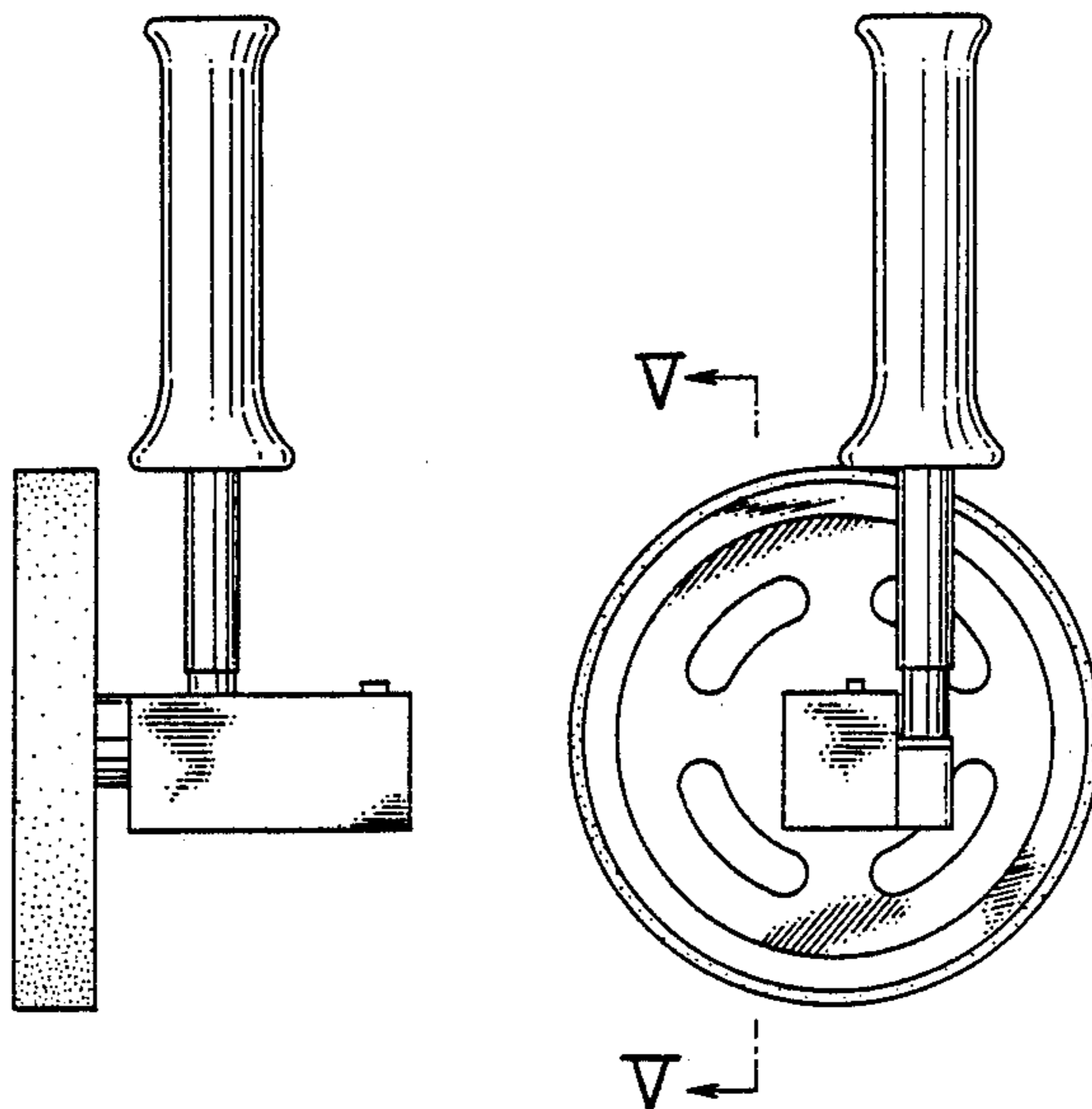

Fig. 3

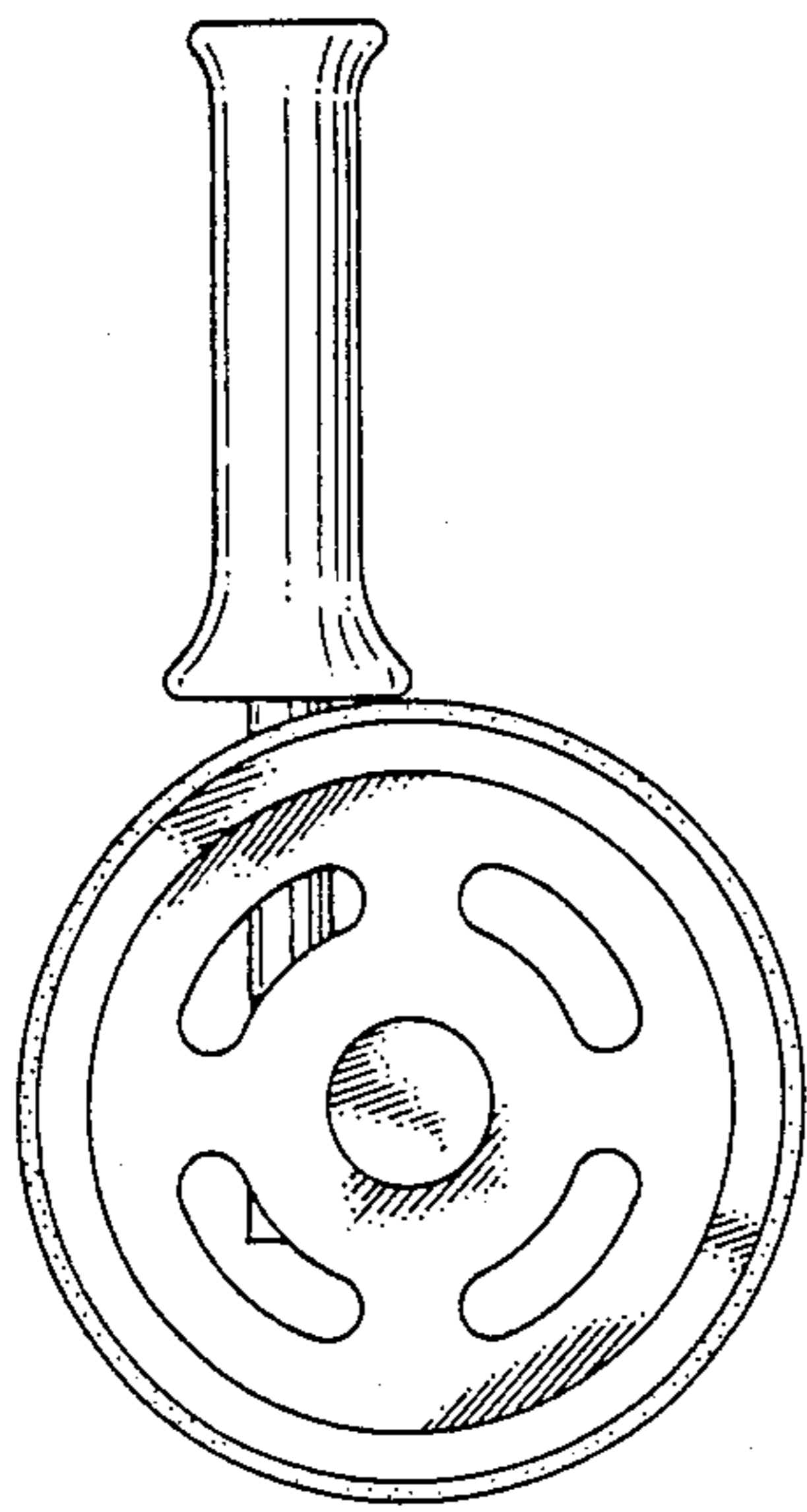

Fig. 1

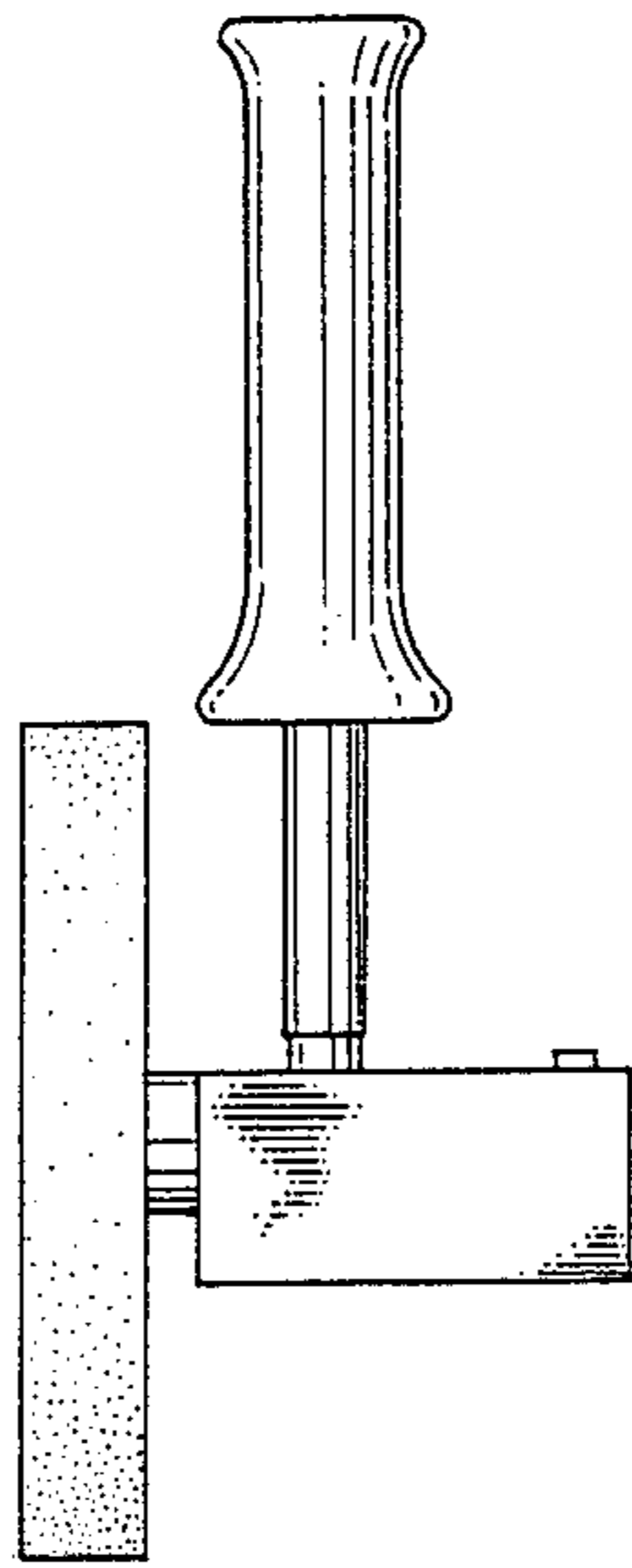

Fig. 4

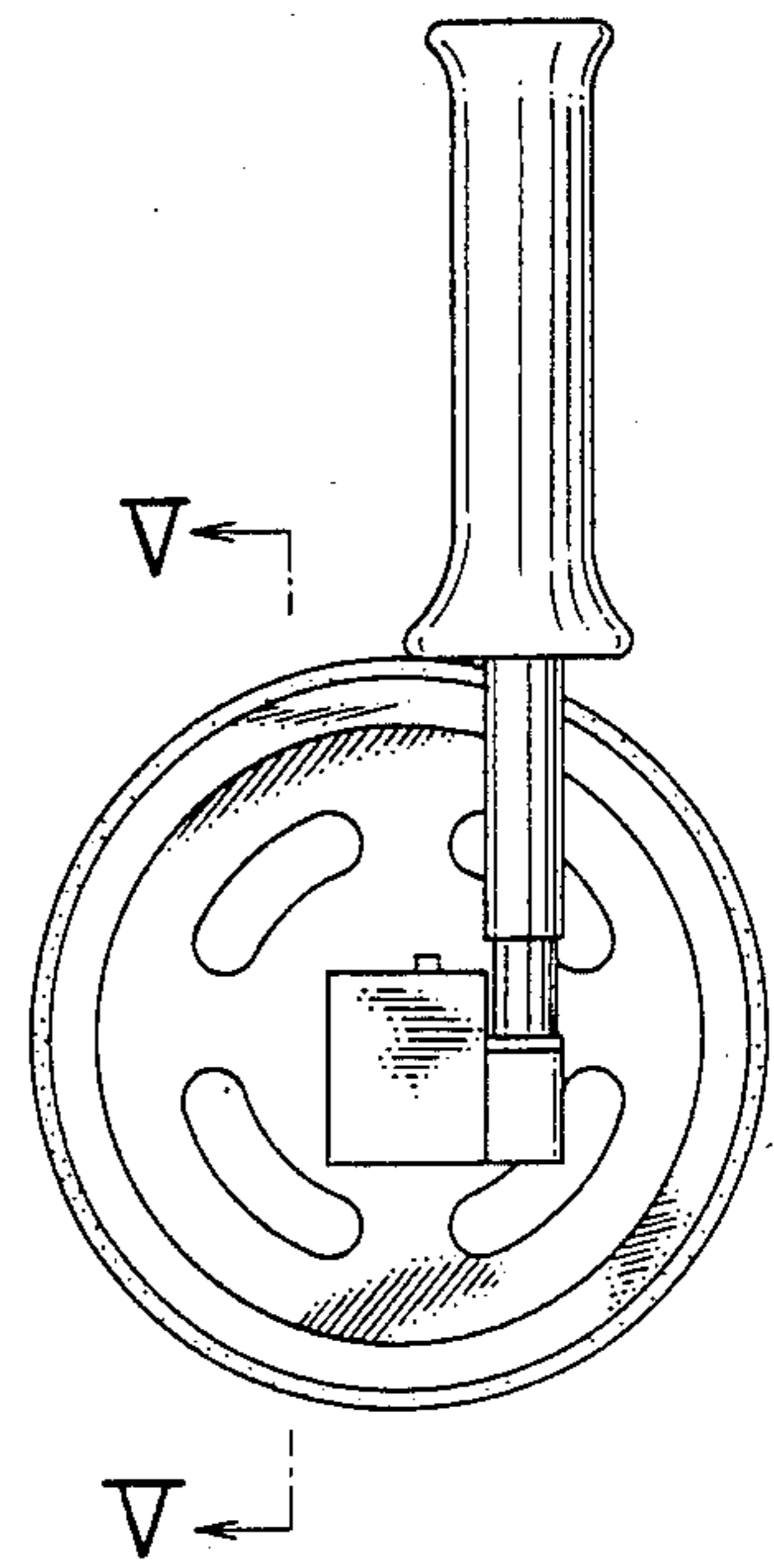

Fig. 2

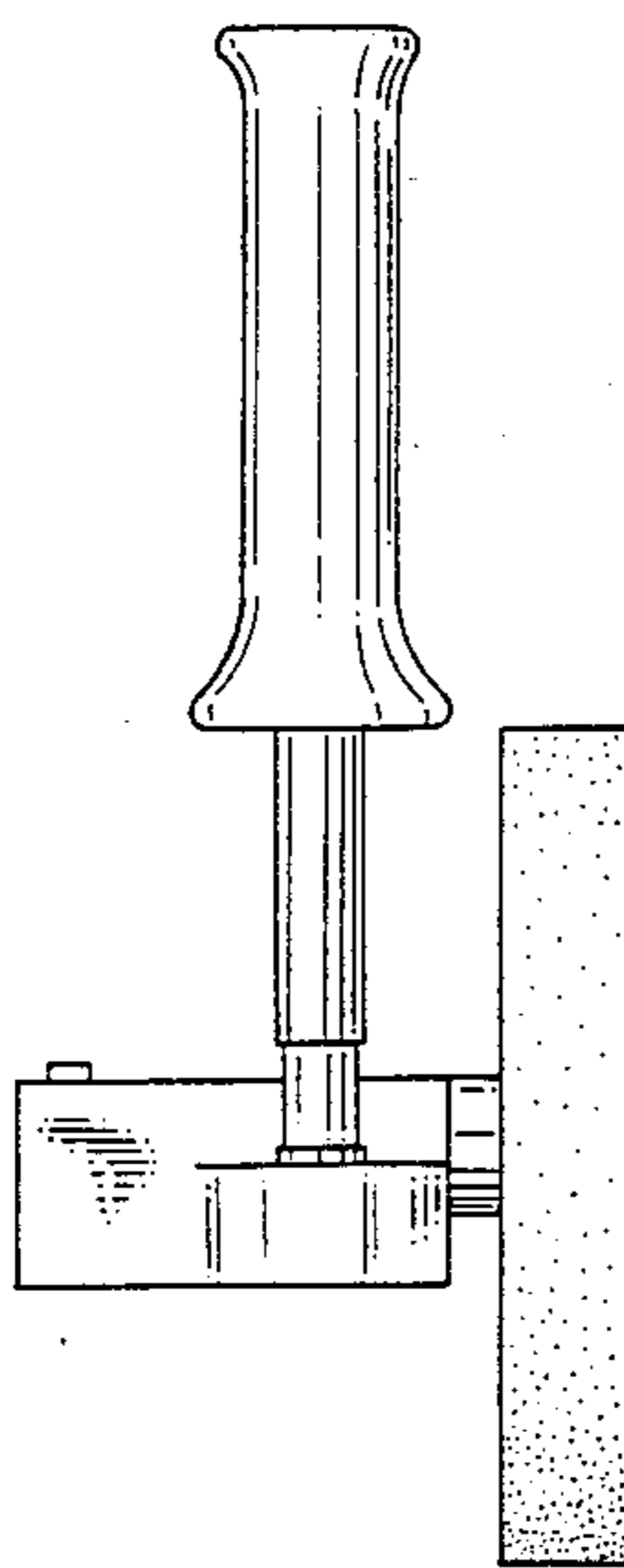

Fig. 6

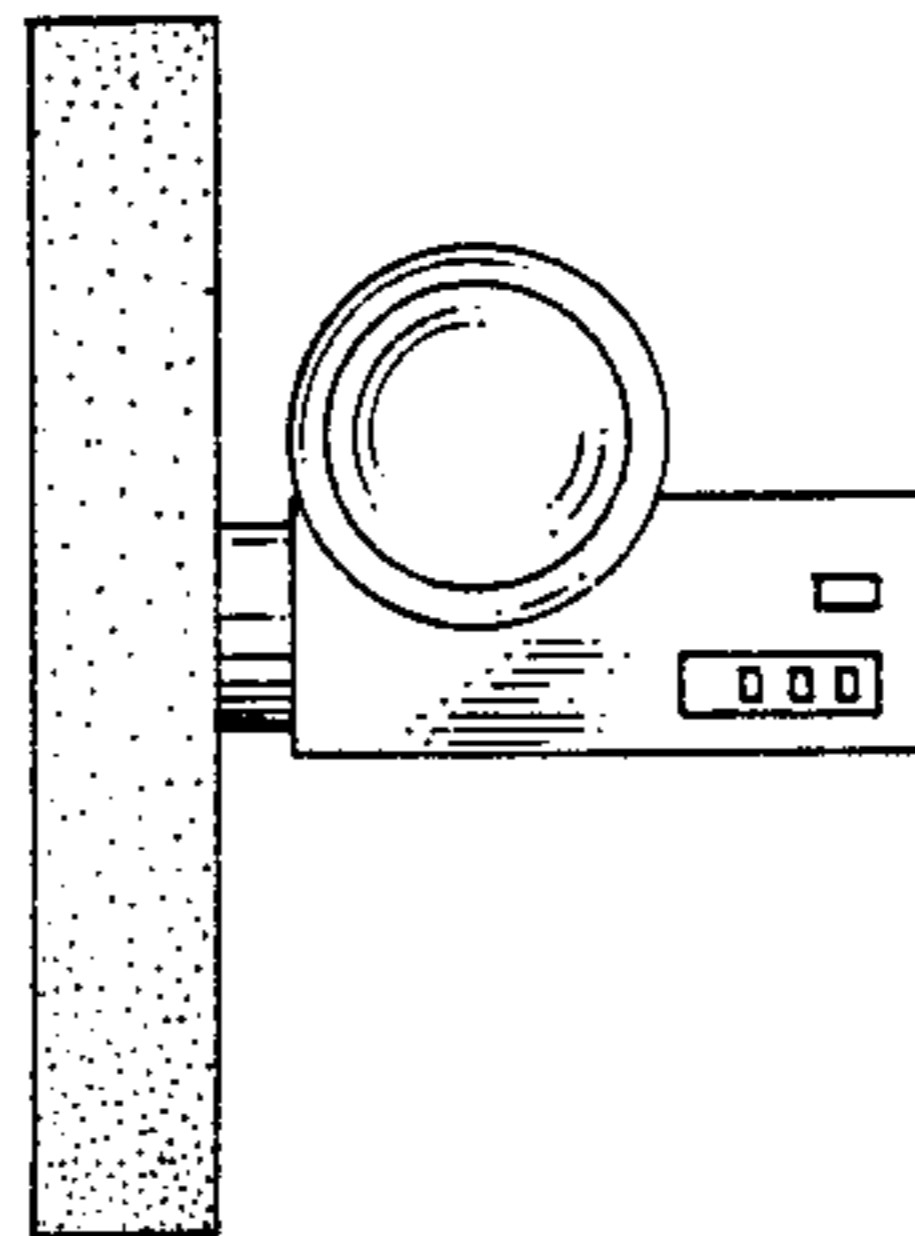

Fig. 7

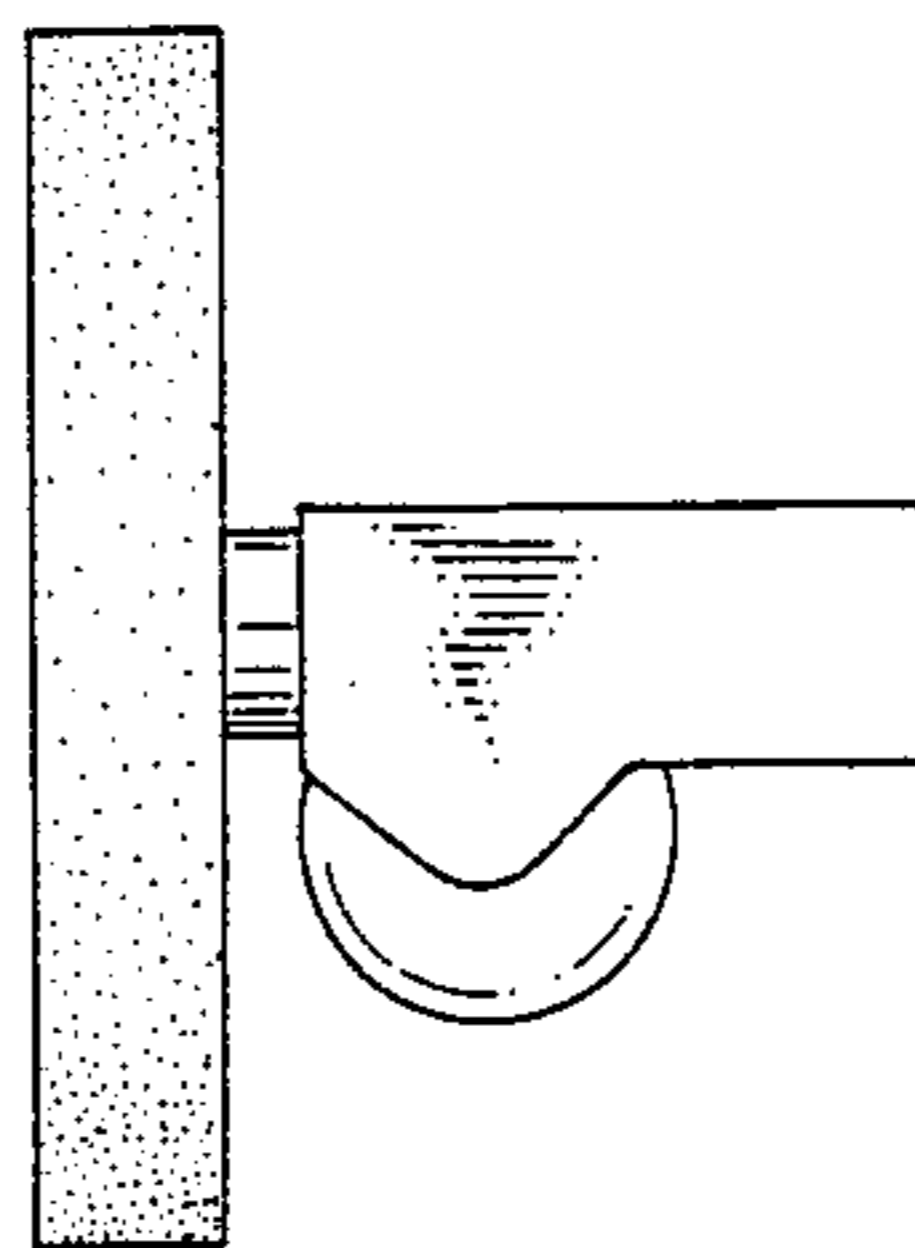

Fig. 8

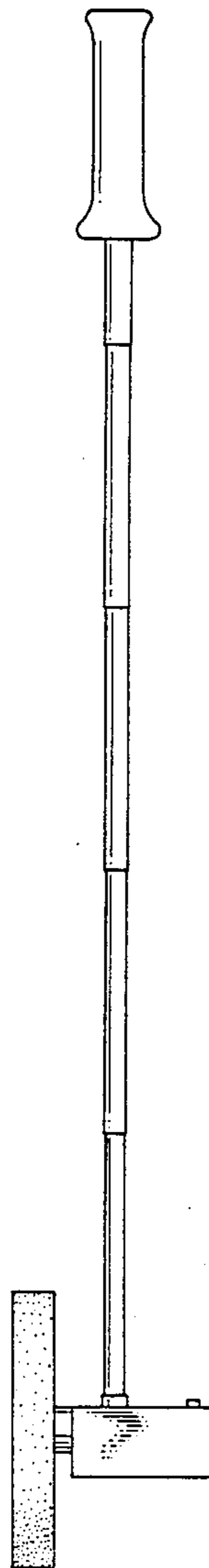

Fig. 5

