

[54] **RESCUE AND ICE FISHING BOAT**

[76] **Inventor: Rolf Olafsen, Lahelleveien 32,
N-3200, Sandefjord, Norway**

[**] **Term: 14 Years**

[21] **Appl. No.: 862,382**

[22] **Filed: May 9, 1986**

[52] **U.S. Cl. D12/300; D12/304**

[58] **Field of Search D12/300, 302, 304, 306,
D12/309, 316; 114/56, 43, 61, 292**

[56] **References Cited**

U.S. PATENT DOCUMENTS

D. 292,908	11/1987	Moar	D12/300
861,607	7/1907	Pfeifer	114/43
3,711,879	1/1973	Siefert	114/43
4,295,236	10/1981	Upchurch	114/61
4,557,210	12/1985	Gerwin	114/61
4,730,569	3/1988	Colson	114/43

FOREIGN PATENT DOCUMENTS

601344 1/1960 Italy 114/61

Primary Examiner—Wallace R. Burke
Assistant Examiner—Kay H. Chin
Attorney, Agent, or Firm—Martin Smolowitz

[57] **CLAIM**

The ornamental design for a rescue and ice fishing boat, as shown and described.

DESCRIPTION

FIG. 1 is a top, side perspective view of a rescue and ice fishing boat showing my new design;
FIG. 2 is a top, rear perspective view thereof, with a hold-on support member included;
FIG. 3 is a top, front perspective view thereof;
FIG. 4 is a bottom perspective view thereof;
FIG. 5 is a top, rear perspective view thereof, with a partial center platform included; and
FIG. 6 is a top, rear perspective view thereof, with a full center platform included.
The oar locks have been omitted in FIG. 1 for clarity of illustration.

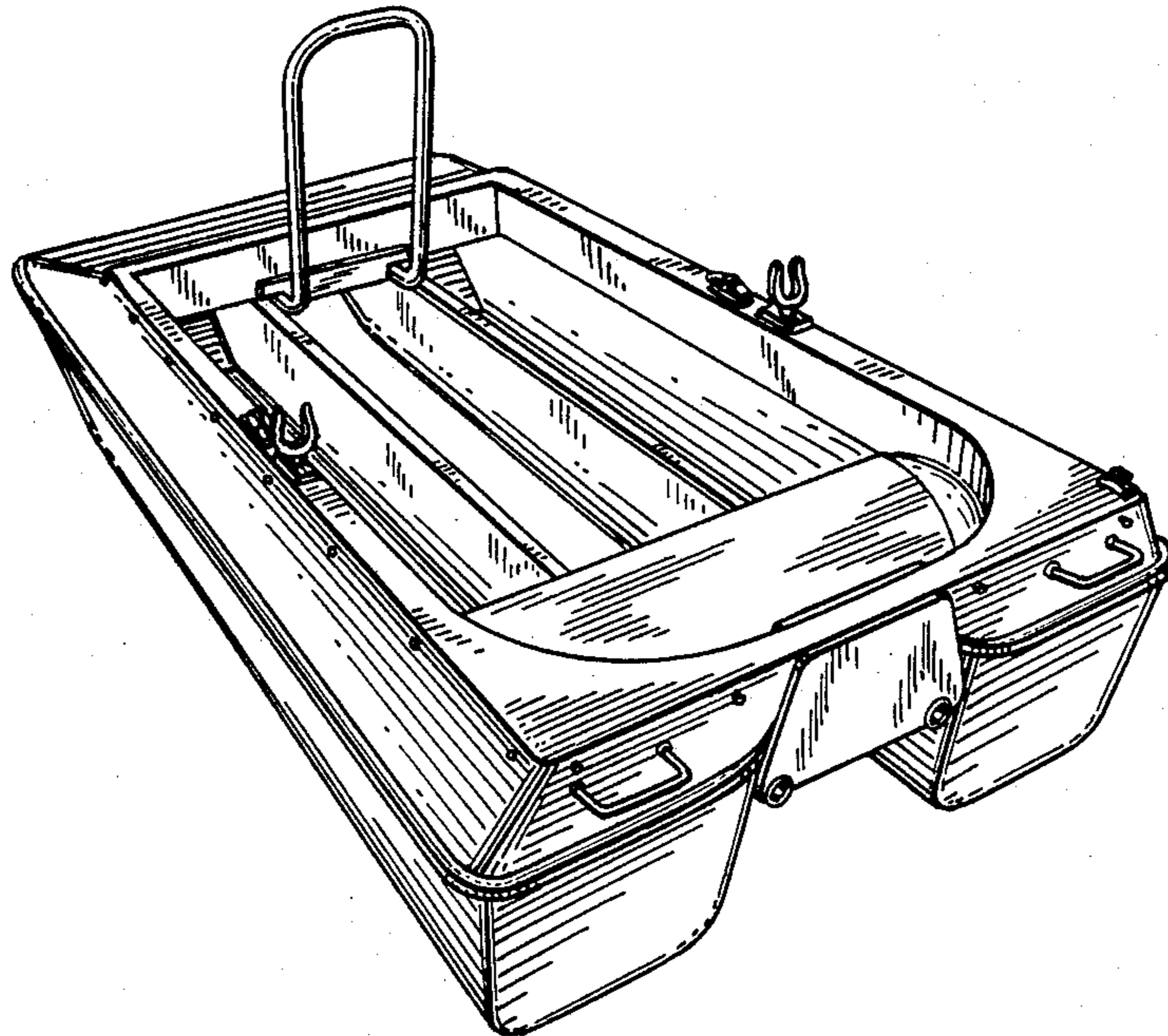

FIG. 1

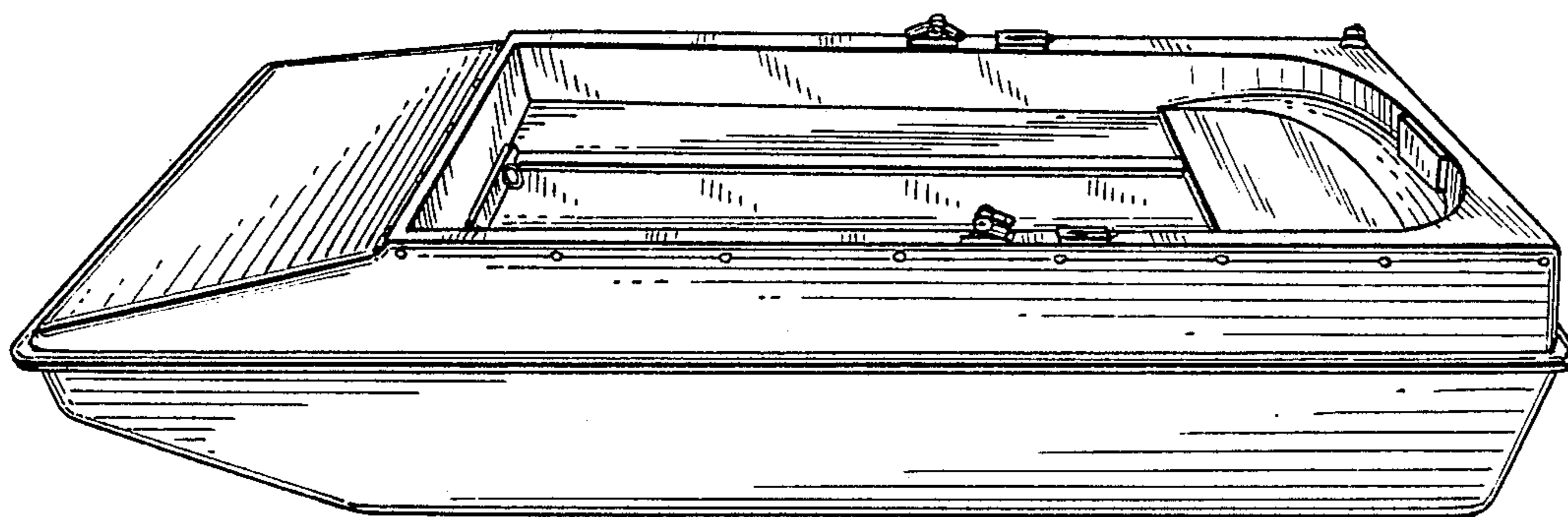

FIG. 2

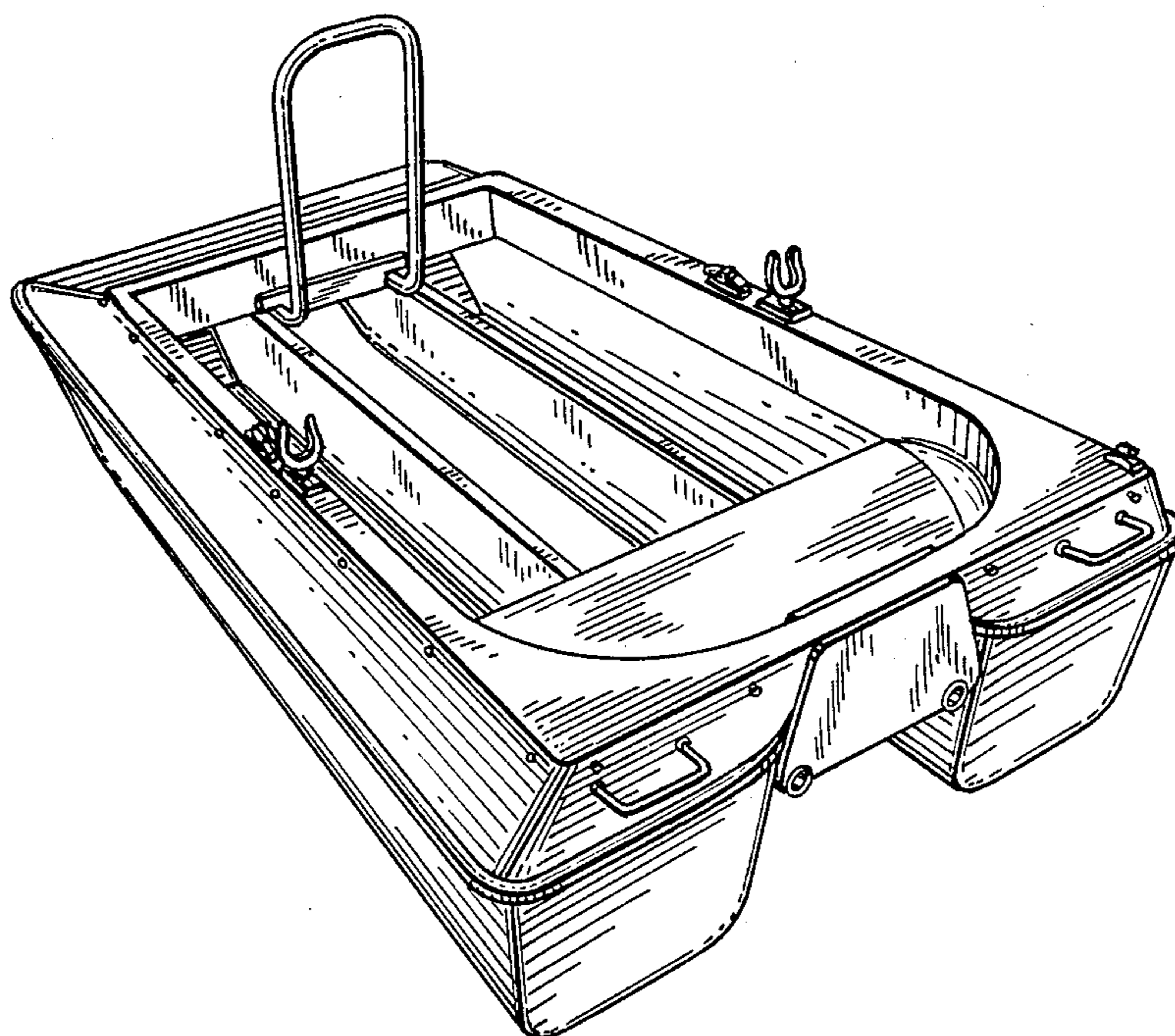

FIG. 3

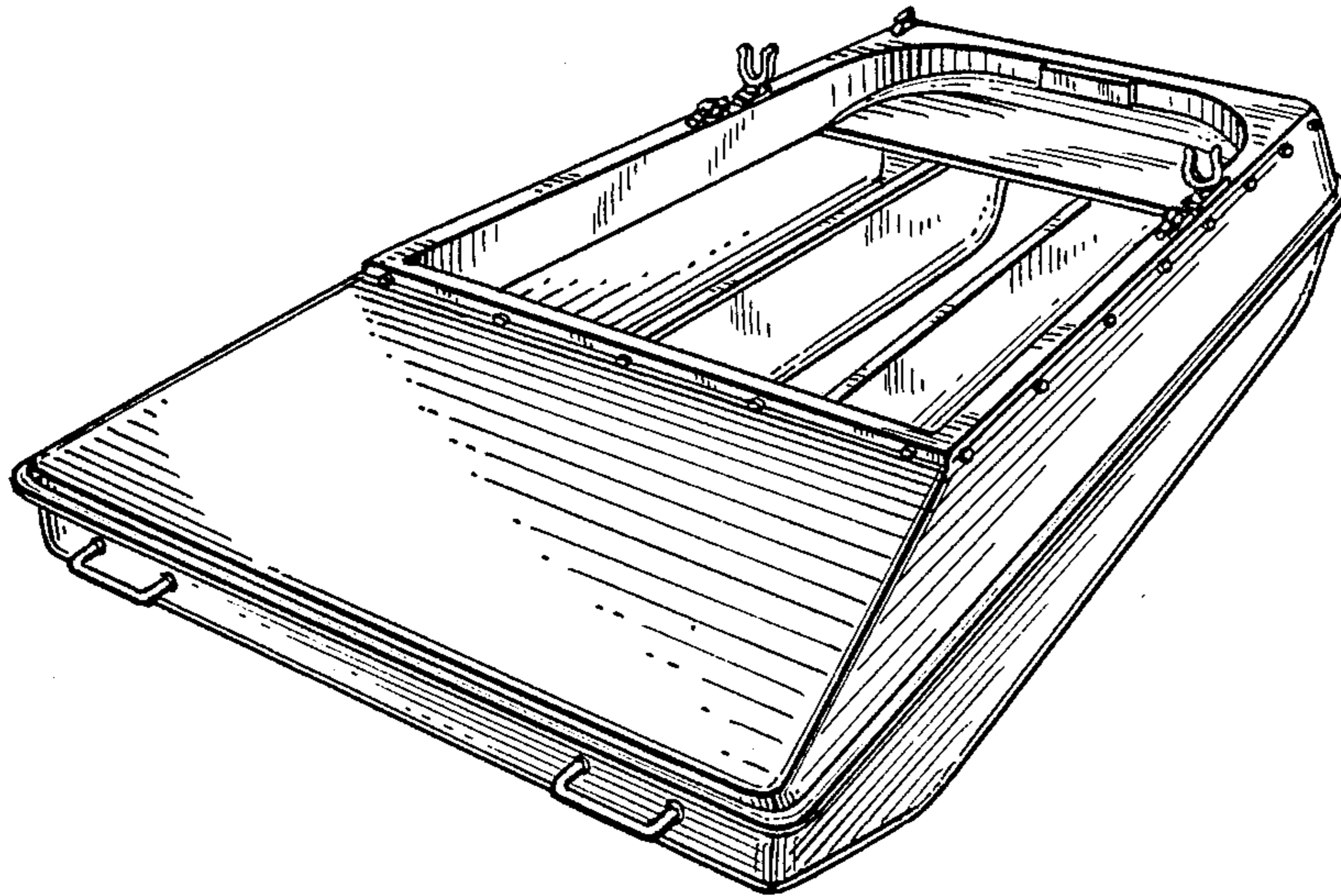

FIG. 4

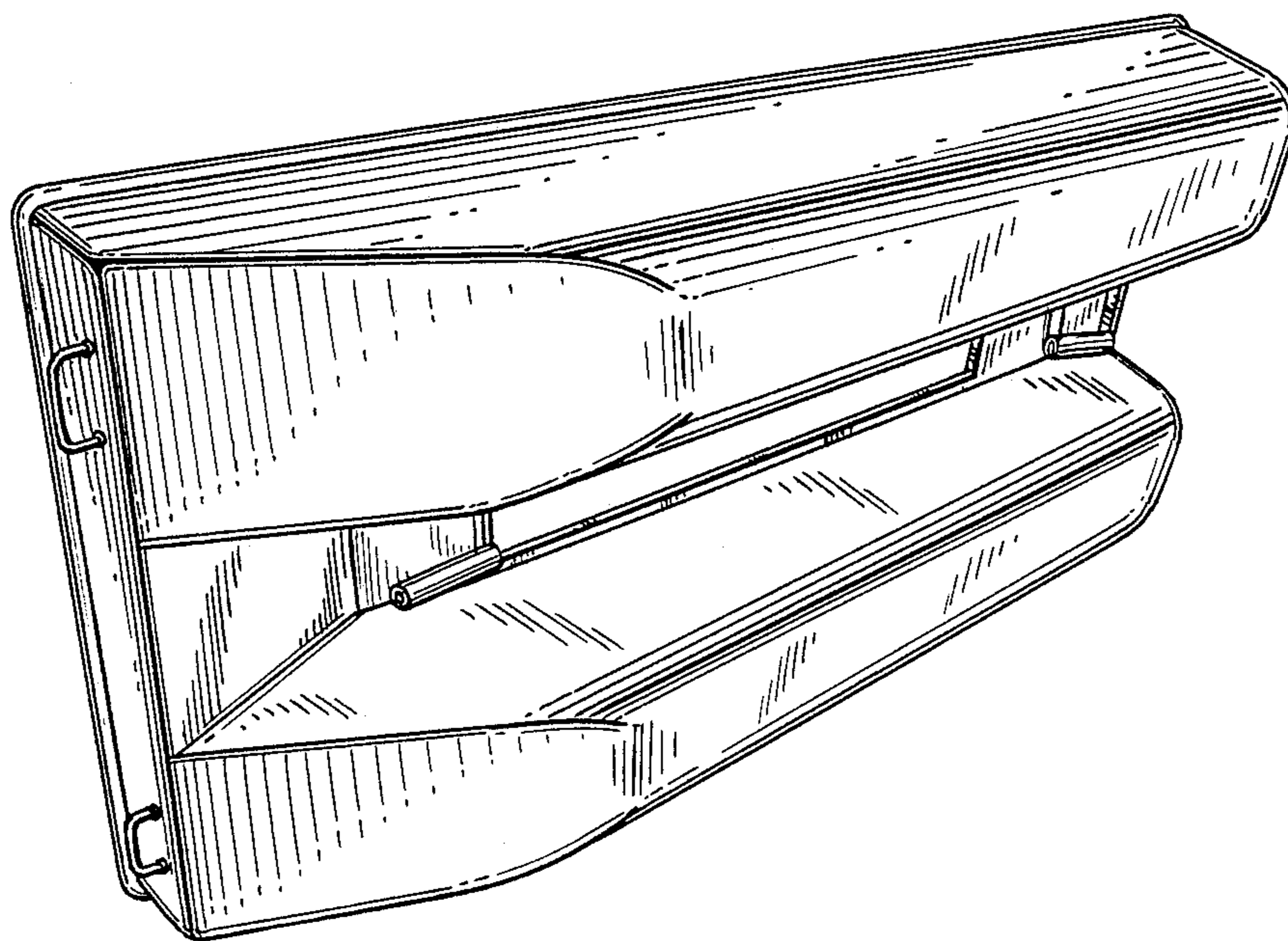

FIG. 5

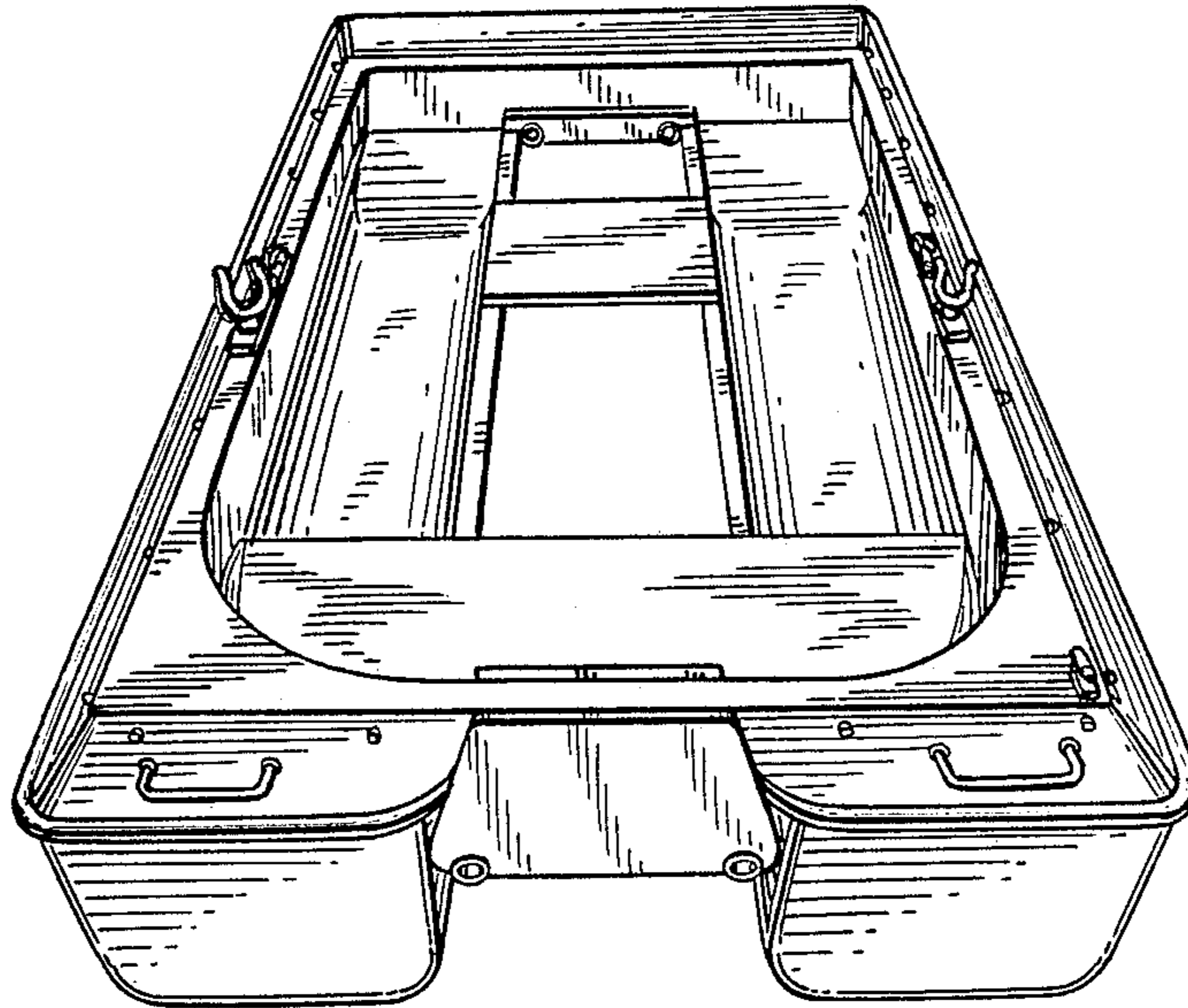

FIG. 6

